



Wire Wound Chip Inductors

SWI1008FT Series



千如電子集團
ABC ELECTRONICS GROUP.

AOBA Technology (M) Sdn. Bhd.

INTRODUCTION

The SWI series are wire wound chip inductors widely used in the communication applications such as cellular phones, cable modem, ADSL, repeaters, Bluetooth, and other electronic devices. The wire wound inductors advance in higher self resonate frequency, better Q factor, and much more stable performance.

FEATURES

- Operating temperature -40 to +85°C for ferrite series.
- Excellent solderability and resistance to soldering heat.
- Suitable for reflow soldering.
- High reliability and easy surface mount assembly.
- Wide range of inductance values are available for flexible needs.

PART NUMBER

SWI 1008 F T 1R0 J - □□

1 2 3 taping 4 5 6

1 Product Type

2 Chip Dimension

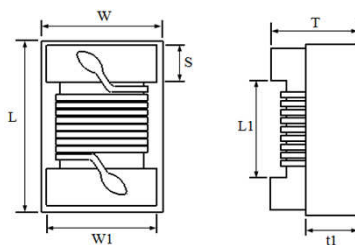

Size (inch) mm	Length (L) (inch) mm	Width (W) (inch) mm	Thickness (T) (inch) mm	Terminal (S) (inch) mm	L1 (Ref.) mm	W1 (Ref.) mm	t1 (Ref.) mm
SWI 1008 2520	(0.102 ± 0.008) 2.60 ± 0.20	(0.083 ± 0.008) 2.10 ± 0.20	(0.067 ± 0.008) 1.70 ± 0.20	(0.020 ± 0.004) 0.50 ± 0.10	1.40	*1.60~1.9	0.70

3 Material Type F : Ferrite

4 Inductance Value R47 = 0.47uH 4R7 = 4.7uH 100 = 10uH

5 Tolerance J = ±5% K = ±10%

6 Internal Code

1 Scope

This specification applies to fixed inductors of the following types used in electronic equipment :

*Ferrite Type : For higher inductance at lower frequency circuit requirement.

2 Construction

*Configuration & Dimension : Please refer to the attached figures and tables.

*Terminals : Consist of Ag alloy followed by Nickel, then Sn plating for easier soldering.

3 Operating Temperature Range

Operating Temperature Range is the scope of ambient temperature at which the inductor can be operated continuously at rated current.

*Temp. Range : Ferrite material : -40°C ~ +85°C

4 Ingredient of terminals electrode

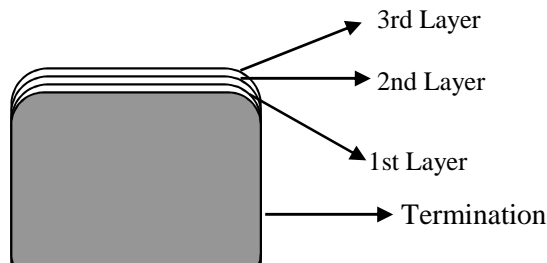

Ferrite Type :

1st Layer : Ag

2nd Layer : Nickel (Ni)

3rd Layer : Tin (Sn)

5 Characteristics

Standard Atmospheric Conditions

Unless otherwise specified, the standard range of atmospheric conditions for making measurements and tests are as follows:

Ambient Temperature : 25°C ± 2°C

Relative Humidity : 60% to 70%

Air Pressure : 86Kpa to 106Kpa

Temperature Profile

1 Reflow Temperature Profile

(Temperature of the mounted parts surface on the printed circuit board)

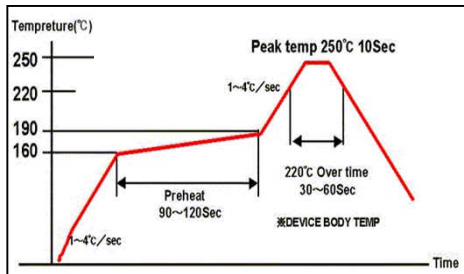

Recommended Peak Temperature : 250°C Max

250°C up /within 10secs

Max. Reflow temperature : 260°C

Gradient of temperature rise : av 1-4°C/sec

Preheat : 160-190°C/within 90-120secs

220°C up /within 30-60secs

Composition of solder Sn-3Ag-0.5Cu

2 Dip Temperature

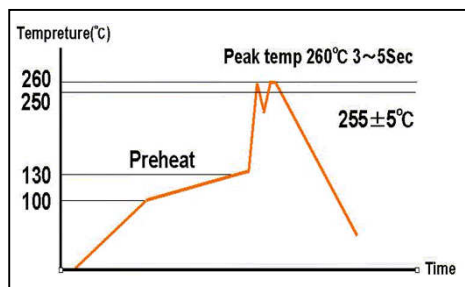
Solder bathtub temperature : 260°C max
within 5secs.Preheating temperature : 100~130°C
deposit solder temperature.

Composition of solder Sn-3Ag-0.5Cu

3 Soldering iron tip temperature : 350°C max / within 3 seconds.

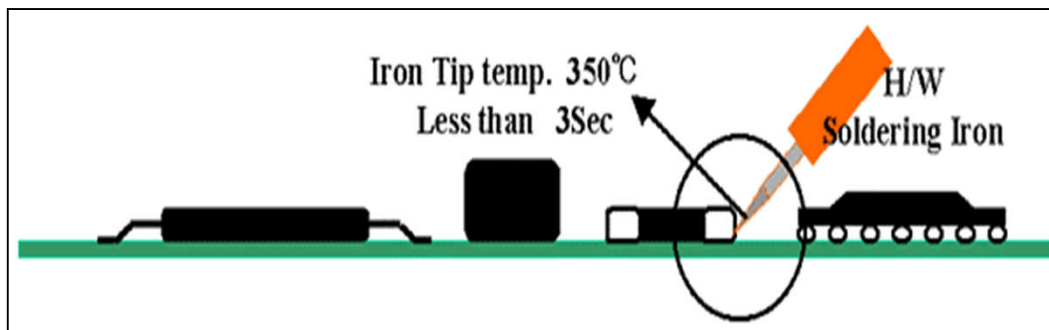

SWI1008FT Series

Part No.	Inductance ¹ (uH)	Tolerance	Q ² Min	S.R.F. ³ Min (MHz)	RDC ⁴ Max (Ω)	IDC ⁵ Max (mA)	Marking
SWI1008FT R47 □-□□	0.47 @ 25MHz	K, J	45 @ 100MHz	480	0.55	500	R47
SWI1008FT R56 □-□□	0.56 @ 25MHz	K, J	45 @ 100MHz	430	0.60	500	R56
SWI1008FT R68 □-□□	0.68 @ 25MHz	K, J	45 @ 100MHz	380	0.80	500	R68
SWI1008FT R82 □-□□	0.82 @ 25MHz	K, J	45 @ 100MHz	350	0.92	500	R82
SWI1008FT 1R0 □-□□	1.0 @ 25MHz	K, J	35 @ 50MHz	310	1.75	430	1R0
SWI1008FT 1R2 □-□□	1.2 @ 7.96MHz	K, J	20 @ 7.96MHz	280	1.30	230	1R2
SWI1008FT 1R5 □-□□	1.5 @ 7.96MHz	K, J	20 @ 7.96MHz	250	1.65	220	1R5
SWI1008FT 1R8 □-□□	1.8 @ 7.96MHz	K, J	20 @ 7.96MHz	200	2.20	210	1R8
SWI1008FT 2R2 □-□□	2.2 @ 7.96MHz	K, J	20 @ 7.96MHz	160	2.35	200	2R2
SWI1008FT 2R7 □-□□	2.7 @ 7.96MHz	K, J	20 @ 7.96MHz	130	2.60	195	2R7
SWI1008FT 3R3 □-□□	3.3 @ 7.96MHz	K, J	20 @ 7.96MHz	80	2.85	185	3R3
SWI1008FT 3R9 □-□□	3.9 @ 7.96MHz	K, J	20 @ 7.96MHz	50	4.00	180	3R9
SWI1008FT 4R7 □-□□	4.7 @ 7.96MHz	K, J	20 @ 7.96MHz	45	4.30	175	4R7
SWI1008FT 5R6 □-□□	5.6 @ 7.96MHz	K, J	20 @ 7.96MHz	42	2.60	170	5R6
SWI1008FT 6R8 □-□□	6.8 @ 7.96MHz	K, J	20 @ 7.96MHz	39	2.80	165	6R8
SWI1008FT 8R2 □-□□	8.2 @ 7.96MHz	K, J	20 @ 7.96MHz	36	3.05	160	8R2
SWI1008FT 100 □-□□	10 @ 2.52MHz	K, J	15 @ 2.52MHz	33	3.50	150	100
SWI1008FT 120 □-□□	12 @ 2.52MHz	K, J	15 @ 2.52MHz	30	3.60	140	120
SWI1008FT 150 □-□□	15 @ 2.52MHz	K, J	15 @ 2.52MHz	26	4.00	130	150
SWI1008FT 180 □-□□	18 @ 2.52MHz	K, J	15 @ 2.52MHz	24	4.50	120	180
SWI1008FT 220 □-□□	22 @ 2.52MHz	K, J	15 @ 2.52MHz	22	5.00	110	220
SWI1008FT 270 □-□□	27 @ 2.52MHz	K, J	15 @ 2.52MHz	21	6.00	95	270
SWI1008FT 330 □-□□	33 @ 2.52MHz	K, J	15 @ 2.52MHz	20	6.50	85	330
SWI1008FT 390 □-□□	39 @ 2.52MHz	K, J	15 @ 2.52MHz	18	8.50	60	390
SWI1008FT 470 □-□□	47 @ 2.52MHz	K, J	15 @ 2.52MHz	17	14.00	45	470

1. Inductance is measured in HP-4287A RF LCR meter with HP-16193 fixture.
2. Q is measured in HP-4287A RF LCR meter with HP-16193 fixture.
3. SRF is measured in ENA E5071B network analyzer or equivalent.

4. RDC is measured in HP-4338B milliohmeter or equivalent.

5. For 15 °C Rise.

Remarks :

Unit weight = 0.025g (for ref.)

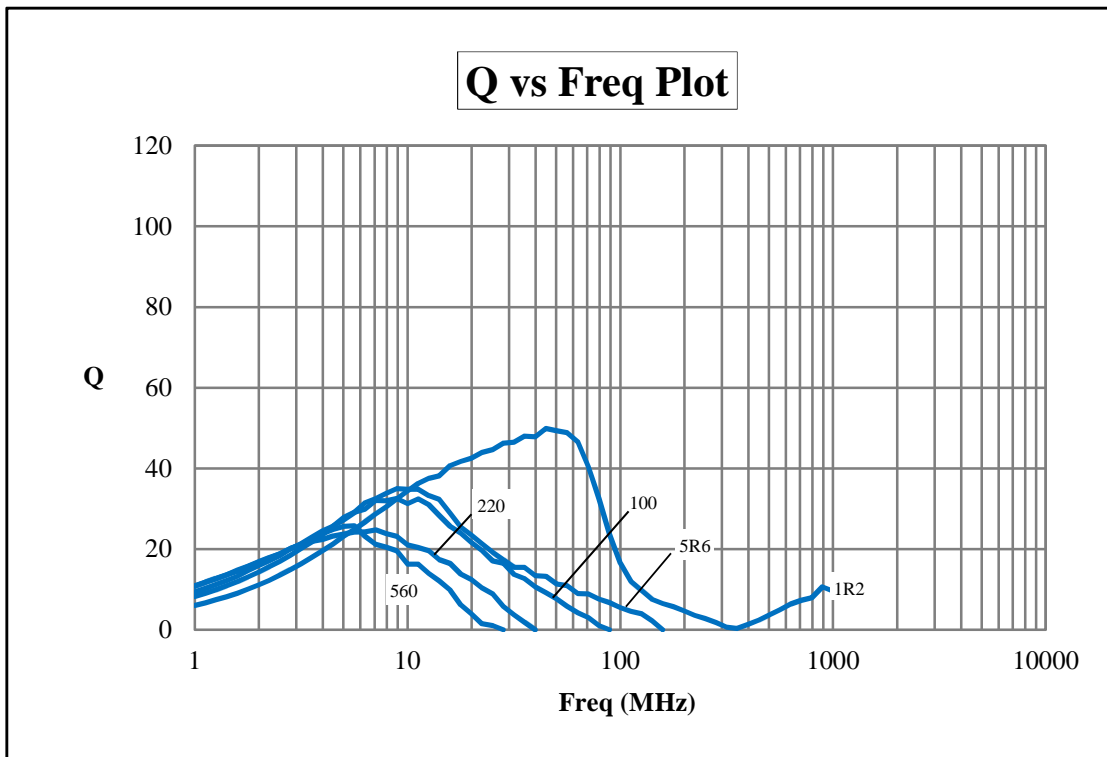
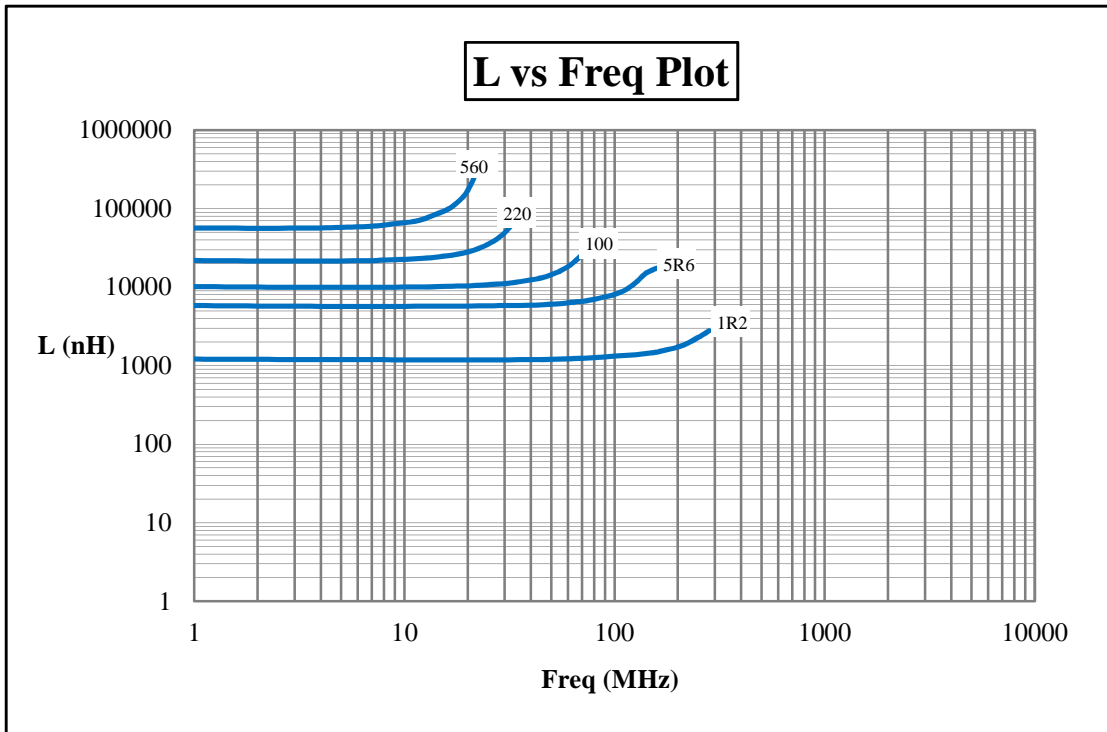

ITEM		CONDITION	SPECIFICATION
Electrical Characteristics	Inductance and Tolerance	Measuring Frequency : As shown in Product Table	Within Specified Tolerance
	Quality Factor	Measuring Temperature : +25°C	
	Insulation Resistance	Measured at 100V DC between inductor terminals and center of case.	1000 mega ohms minimum
	Dielectric Withstanding Voltage	Measured at 500V AC between inductor terminals and center of case for a maximum of 1 minute.	No damage occurs when the test voltage is applied.
	Temperature Coefficient of Inductance (TCL)	Over -40°C to +85°C at frequency specified in Product Table.	+25 to 500 ppm/°C $TCL = \frac{L1 - L2}{L1(T1 - T2)} \times 10^6$ (ppm /°C)
Mechanical Characteristics	Component Adhesion (Push Test)	The component shall be reflow soldered onto a P.C. Board (240°C ± 5°C for 20 seconds). Then a dynamometer force gauge shall be applied to any side of the component.	0402 series - 350g 0603 series - 1.0Kg Other series - 0805 ~ 1210 Minimum 1Kg for Ag termination and 2Kg for Mo/Mn termination.
	Drop Test	The inductor shall be dropped two times on the concrete floor or the vinyl tile from 1M naturally.	Change In Inductance: No more than 5%
	Thermal Shock Test	Each cycle shall consist of 30 minutes at -40°C followed by 30 minutes at +85°C with a 5 minutes transition time between temperature extremes. Test duration is 10 cycles.	Change In Q: No more than 10% Change In Appearance: Without distinct damage
Endurance Characteristics	Solderability	Dip pads in flux and dip in solder pot containing lead free solder at 240°C ± 5°C for 5 seconds.	A minimum of 80% of the metalized area must be covered with solder.
	Resistance to Soldering Heat	Dip the components into flux and dip into solder pot containing lead free solder at 260°C ± 5°C for 5 ± 2 seconds.	Change In Inductance: No more than 5% Change In Q: No more than 10% Change In Appearance: Without distinct damage
	Vibration (Random)	Inductors shall be randomly vibrated at amplitude of 1.5mm and frequency of 10-55Hz : 0.04G/Hz for a minimum of 15 minutes per axis for each of the three axes.	
	Cold Temperature Storage	Inductors shall be stored at temperature of -40°C ± 2°C for 1000hrs (+48 -0 hrs.) Then inductors shall be subjected to standard atmospheric conditions for 1 hour. After that, measurement shall be made.	
	High Temperature Storage	Inductors shall be stored at temperature of 85°C ± 2°C for 1000hrs (+48 -0 hrs.) Then inductors shall be subjected to standard atmospheric conditions for 1 hour. After that, measurement shall be made.	
	Moisture Resistance	Inductors shall be stored in the chamber at 45°C at 90-95 R.H. for 1000 hours. Then inductors are to be tested after 2 hours at room temperature.	Inductors shall not have a shorted or open winding.
	High Temperature with Loaded	Inductors shall be stored in the chamber at +85°C for 1000 hours with rated current applied. Inductors shall be tested at the beginning of test at 500 hours and 1000 hours. Then inductors are to be tested after 1 hour at room temperature.	

Type	Pcs/Reel
SWI1008	2,000

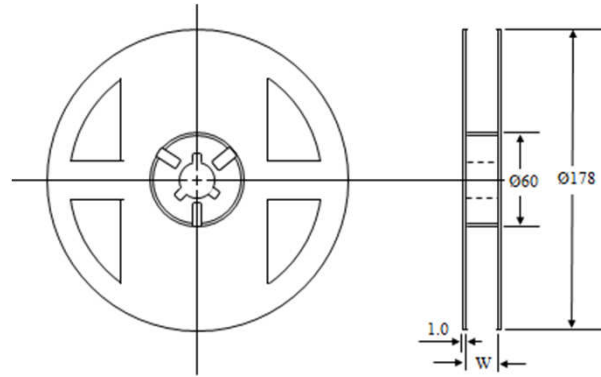

Type	Chip Cavity		Insert Pitch	Tape Thickness		
	A	B	F	K	T	W
SWI1008	2.20	2.83	4.00	1.75	0.22	8.00

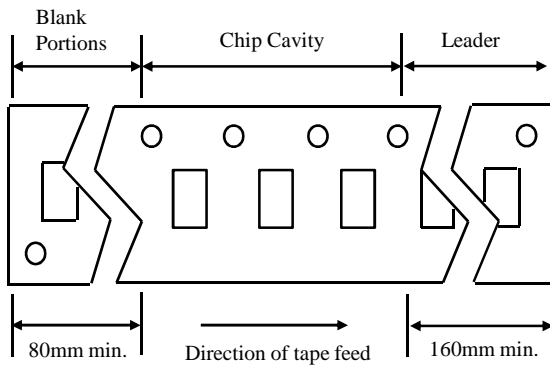
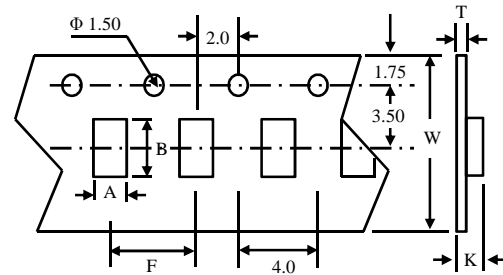

Top Tape Strength

The top tape requires a peel-off force of 0.2 to 0.7N in the direction of the arrow as illustrated below.

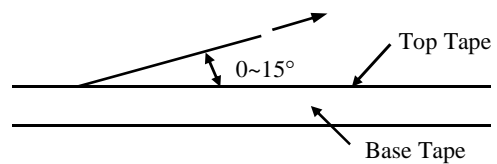

Dimensions (unit : m/m)

Type	A	B	C
SWI1008	3.00	1.20	2.20

Recommended Pattern

