

# SPECIFICATION FOR APPROVAL

REF. :

PROD. NAME	Shielded SMD Power Inductor	ABC'S DWG NO.	SU5028□□□□L□-□□□		
		REV.	20150709-F	PAGE	1

## I . Configuration and dimensions :

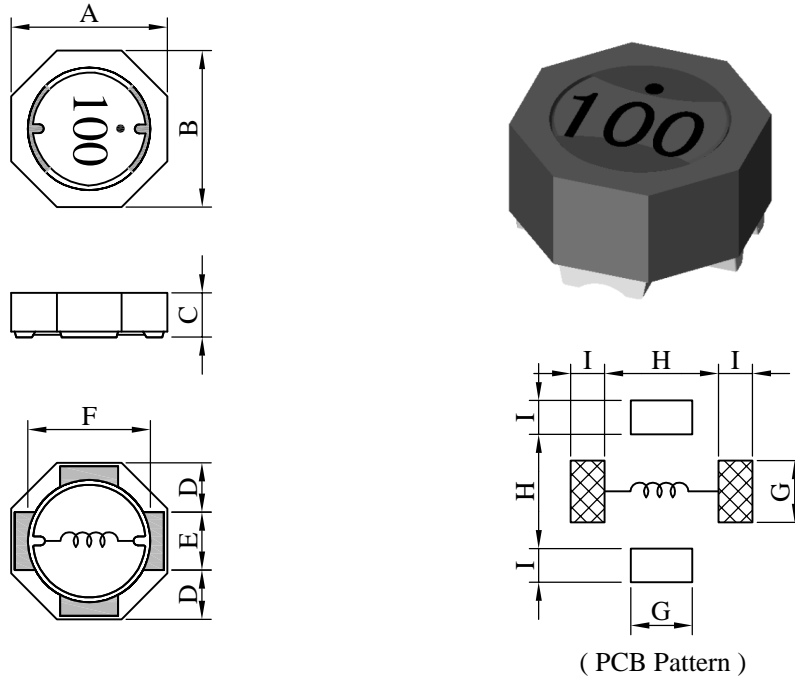

Unit : m/m

A	B	C	D	E	F	G	H	I
5.20 ±0.20	5.20 ±0.20	2.80 ±0.20	1.70 typ.	1.80 typ.	3.90 typ.	2.00 ref.	3.70 ref.	1.10 ref.

## II . Description :

- a . Ferrite drum core construction.
- b . Magnetically shielded.
- c . Enamelled copper wire : F · H class
- d . Product weight : 0.27 g ( ref. )
- e . Moisture sensitivity Level 1
- f . Products comply with RoHS' requirements
- g . Halogen free available

Peak Temp : 250°C max.  
Max. Peak Temp - 5°C : 30sec max.  
Max time above 217°C : 60sec~150sec max.

## III . General specification :

- a . Storage temp. : -55°C ----+125°C
- b . Operating temp. : -40°C ----+125°C  
( Temp. rise included. )
- c . Resistance to solder heat : 250°C.10 secs.

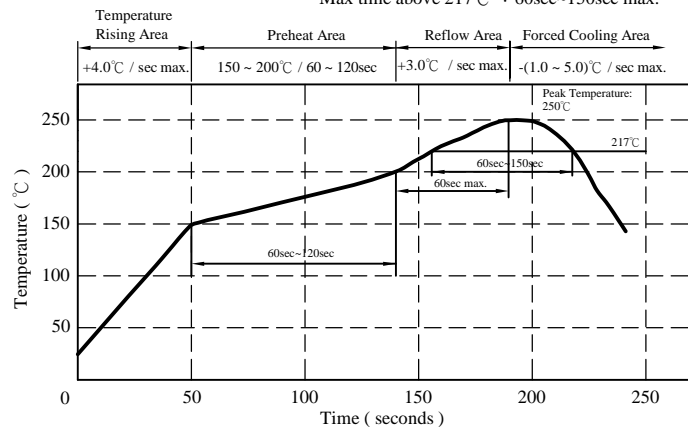

AR-001C

# SPECIFICATION FOR APPROVAL

REF. :

PROD. NAME	Shielded SMD Power Inductor	ABC'S DWG NO.	SU5028□□□□L□-□□□		
		REV.	20150709-F	PAGE	2

IV . Electrical characteristics :

DWG No.	Inductance ( μH )	Q ref.	Test Freq. ( Hz )		RDC ( mΩ )		SRF ( MHz ) typ.	Irms ( mA ) typ.	Isat ( mA ) typ.
			L	Q	typ.	max.			
SU50281R2YL□-□□□	1.2 ± 30 %	10.0	100k	7.96M	16.8	22.0	200	3500	3400
SU50282R2YL□-□□□	2.2 ± 30 %	10.0	100k	7.96M	21.0	27.0	130	3200	2500
SU50283R3YL□-□□□	3.3 ± 30 %	10.0	100k	7.96M	24.0	32.0	90	2800	2100
SU50284R7YL□-□□□	4.7 ± 30 %	9.0	100k	7.96M	32.0	45.0	50	2200	1850
SU50286R8YL□-□□□	6.8 ± 30 %	10.0	100k	7.96M	42.0	56.0	55	2000	1550
SU5028100YL□-□□□	10.0 ± 30 %	18.0	100k	2.52M	63.0	85.0	25	1800	1400
SU5028150YL□-□□□	15.0 ± 30 %	18.0	100k	2.52M	108.0	140.0	23	1100	1000
SU5028220YL□-□□□	22.0 ± 30 %	15.0	100k	2.52M	162.0	210.0	18	950	850
SU5028330YL□-□□□	33.0 ± 30 %	15.0	100k	2.52M	203.0	260.0	16	800	680
SU5028470YL□-□□□	47.0 ± 30 %	13.0	100k	2.52M	285.0	360.0	13	700	620
SU5028680YL□-□□□	68.0 ± 30 %	13.0	100k	2.52M	450.0	550.0	10	560	460
SU5028101YL□-□□□	100.0 ± 30 %	15.0	100k	796k	625.0	800.0	8	470	420

- 1) . □ : Packaging information : □ Code
- 2) . "- □□□" : Reference code
- 3) . Electrical specifications at 25°C
- 4) . Inductance Test Freq. : 100kHz / 0.1V
- 5) . Isat base on ΔL / LOA=35% typ.
- 6) . Irms base on Temp. rise 40°C typ.

# SPECIFICATION FOR APPROVAL

REF. :

PROD. NAME	Shielded SMD Power Inductor	ABC'S DWG NO.	SU5028□□□□L□-□□□		
		REV.	20150709-F	PAGE	3

V . Curve :

SU50282R2YL□

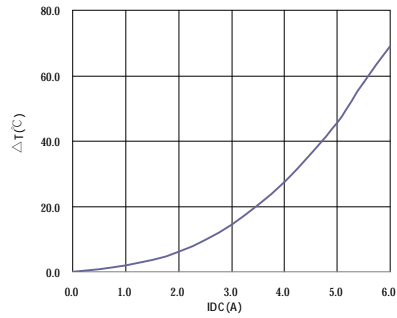
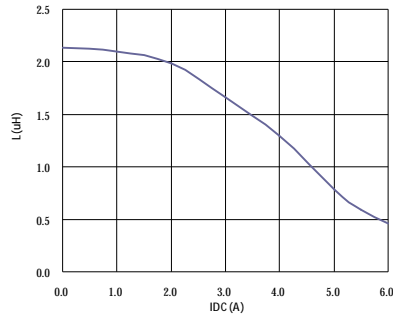

SU50286R8YL□

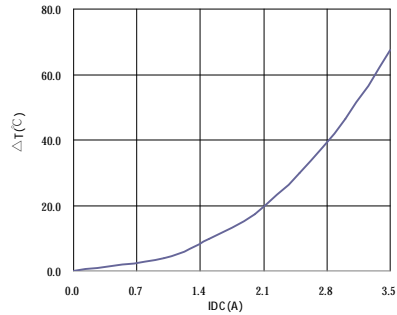
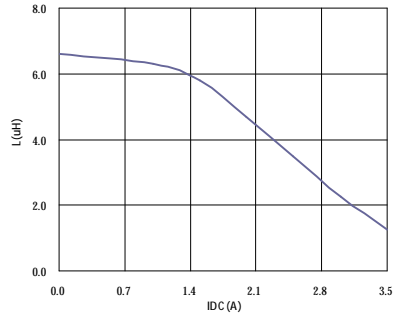

SU5028150YL□

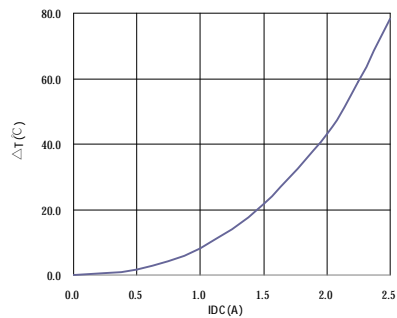
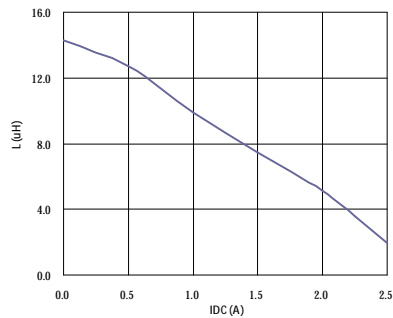

SU5028101YL□

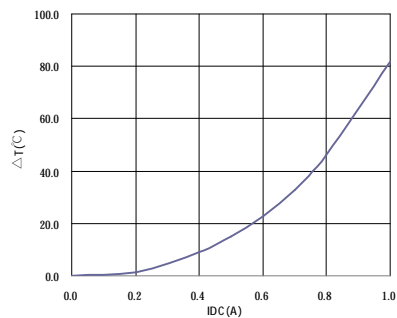
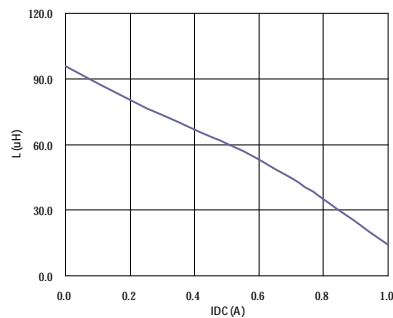

AR-001C

# SPECIFICATION FOR APPROVAL

REF. :

PROD. NAME	Shielded SMD Power Inductor	ABC'S DWG NO.	SU5028□□□□L□-□□□		
		REV.	20150709-F	PAGE	4

## VI . Packaging information :

### (1) Configuration

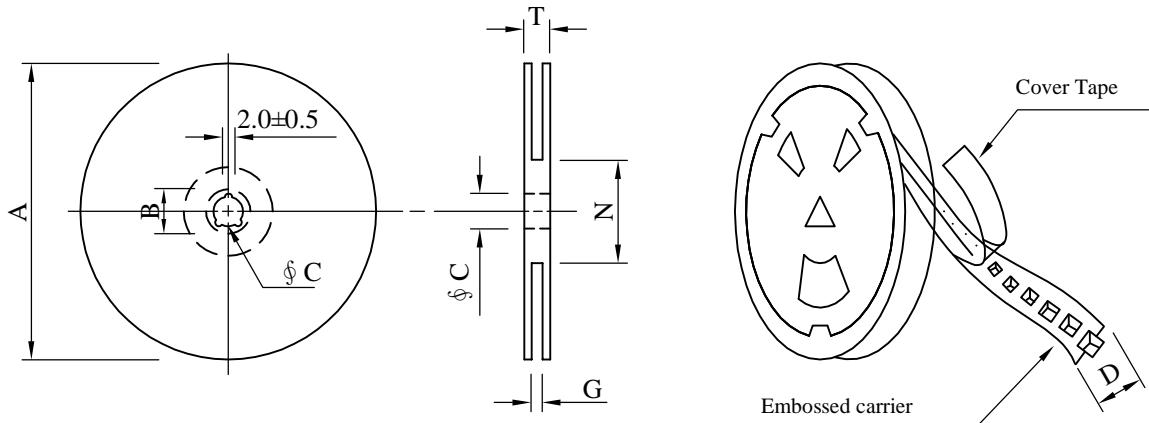

※Carrier tape width : D

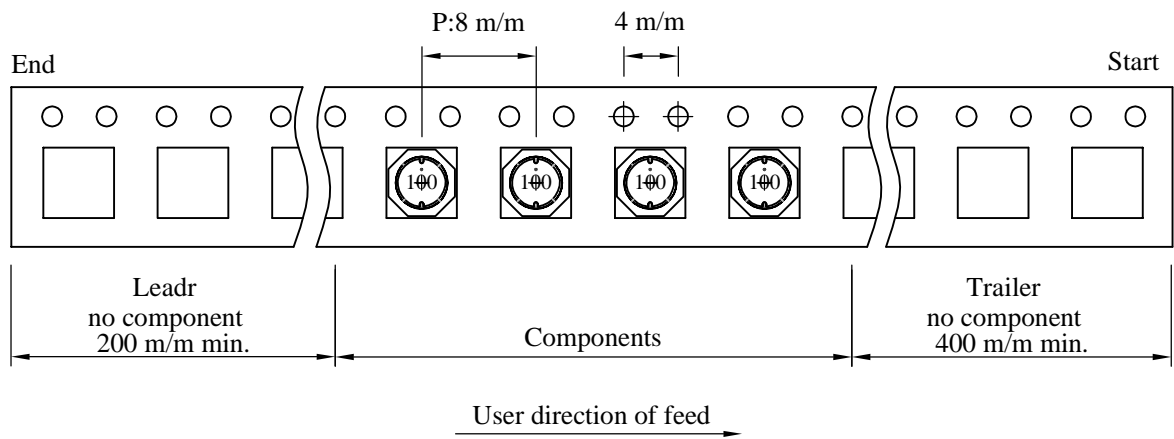

### (2) Dimensions

Unit:m/m

Style	A	B	C	D	G	N	T
07 - 12	178	21±0.8	13	12	14 <sup>+0</sup>	50 <sup>-0</sup>	16.5

### (3) Q'TY & G.W. Per package

Code	Inner : Reel			Outer : Carton		
	Q'TY (pcs)	G.W. (gw)	Style	Q'TY (pcs)	G.W. (Kg)	Size (cm)
B	600	260	07 - 12	24,000	12.0	42 x 41 x 24

AR-001C

# SPECIFICATION FOR APPROVAL

REF. :

<b>PROD. NAME</b>	<b>Shielded SMD Power Inductor</b>	<b>ABC'S DWG NO.</b>	SU5028□□□□L□-□□□		
		<b>REV.</b>	20150709-F	<b>PAGE</b>	5

## VII . Reliability test :

Item	Reference documents	Test Condition	Test Specification
1.High Temperature Exposure	MIL-STD-202 Method 108	1.Temperature: 125±2℃ 2.Time:96±2 hours.	1.No mechanical or electrical damage. 2.Inductance shall not change more than ±20%.
2.Temperature Cycling	JESD22-A 104	1.Temperature: -55℃ ~ +125℃ 2.Number of cycle:100 cycle 3.Dwell time:30 minutes	1.No mechanical or electrical damage. 2.Inductance shall not change more than ±20%.
3.Biased Humidity Test	MIL-STD-202 Method 103	1.Temperature : 85±2 ℃ 2.Humidity: 85% RH. 3.Time:96±2 Hours	1.No mechanical or electrical damage. 2.Inductance shall not change more than ±20%.
4.Operational Life	JESD22-A 108	1.Temperature: 125℃ (Temp. rise included) 2.Time:96±2 hours. 3.Rated current	1.No mechanical or electrical damage. 2.Inductance shall not change more than ±20%.
5.External Visual	JESD22-B 101 & MIL-STD-883 Method 2009	Inspect product constructions, marking and workmanship.	1.No pollution on the surface of products. 2.Clear marking. 3.No crack.
6.Physical Dimensions	JESD22-B 100	Verify physical dimensions to the applicable product detail specification.	Per product specification standard
7.Resistance to solvents	MIL-STD-202 Method 215	Immerse into solvent for 3±0.5 minutes & brush 10 times for 3 cycles.	1.No body change in appearance. 2.No marking blurred. 3.Inductance shall not change more than ±20%.
8.Vibration Test	MIL-STD-202 Method 204	1.Frequency and Amplitued : 10-2000-10 Hz, 1.5 mm. 2.Direction:X, Y, Z 3.Test duration:2 hours for each direction, 6 hours in total.	1.No mechanical or electrical damage. 2.Inductance shall not change more than ±20%.
9.Resistance To Soldering Heat Test	MIL-STD-202 Method 210 & J-STD020D.1	1.Highest temperature : 250±5℃. 2.Time ( temp. ≥ 217℃ ) : 60~150 Second. 3.IR reflow times : 3 times.	1.No mechanical or electrical damage. 2.Inductance shall not change more than ±20%.
10.Saturation Current	JIS C 6436 & User SPEC.	1.Applied rated current for 5 second. 2.Saturation current	Inductance shall not drop more than 35% typ.
11.Over load	JIS C 6436 & User SPEC.	1.Applied one and half rated current for a period of 5 minutes. 2.Rated current	No electrical or mechanical damage
12.Temperature Rise Current	JIS C 6436 & User SPEC.	1.Applied rated current for 10 minutes. 2.Temperature measure by digital surface thermometer. 3.Irms current	Surface temperature rise is less than 40℃ typ.
13.Solderability Test	J-STD-002 & JESD22-B 102	1.Baking in pre-testing : 150±5℃ / 16Hours±30 min. 2.Peak temperature : 240±5℃ 3.Time ( temp. ≥ 217℃ ) : 60~150 second. 4.IR reflow times : 1 times.	More than 95% soldering coverage min on terminations.
14.Electrical Characteriazation	MIL-STD-202 Method 304 & User SPEC.	1.Operating temperature : -40℃~125℃ 2.Room temperature : 25℃.	1.No mechanical or electrical damage. 2.Inductance shall not change more than ±20%.
15.Drop	CNS-C6354 & GB/T 2423.8	1.Products shall be mounted on SPEC. PCB and dropped down from a height of 1m 2.Drop total time : 6 time (Every side of sample drop 2 time)	1. Adhesion on PCB shall be enough. 2. Product appearance shall not break. 3. No electrical damage.
16.Terminal Strength Test	IEC 60068-2-21	1.Apply push force to samples mounted on PCB. 2.Force of 1.8 kg for 60±1 seconds.	After test, inductors shall be no mechanical damage.

AR-001C