

# SPECIFICATION FOR APPROVAL

REF. :

PROD. NAME	Shielded SMD Power Inductor	ABC'S DWG NO.		SU3009□□□□L□-□□□			
		REV.	20151214-D	PAGE	1		

**I . Configuration and dimensions :**

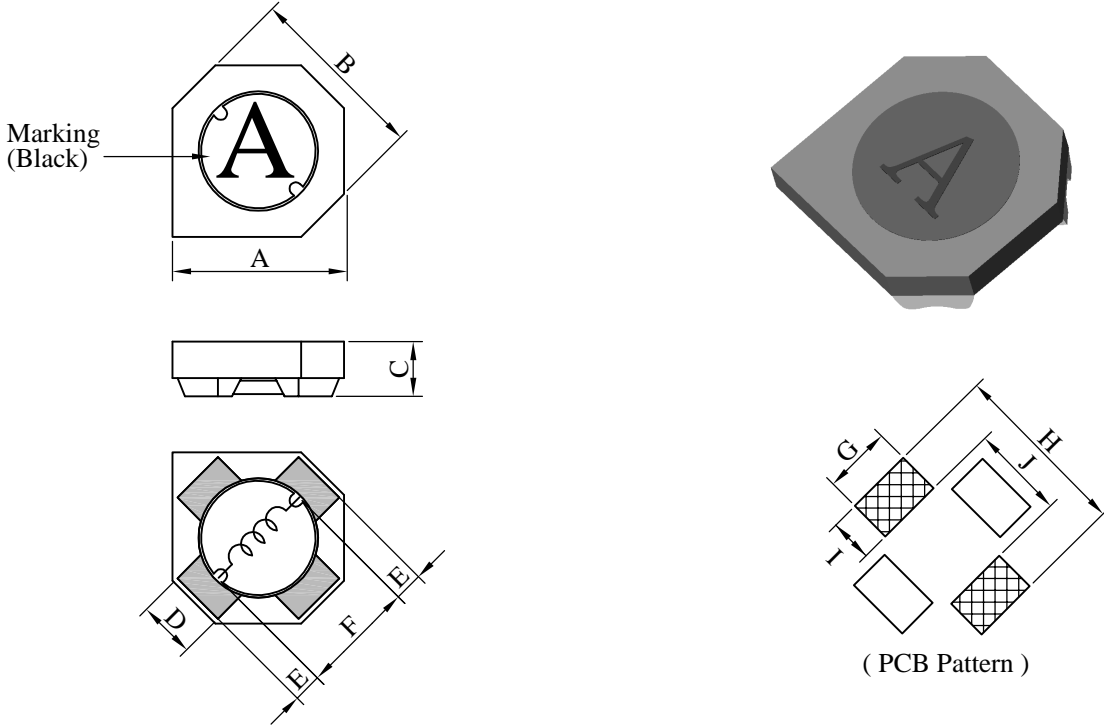

Unit : m/m

A	B	C	D	E	F	G	H	I	J
3.30 ±0.2	3.50 ±0.2	0.95 ±0.1	1.10 typ.	0.50 typ.	2.30 typ.	1.30 ref.	4.20 ref.	1.20 ref.	1.80 ref.

**II . Description :**

- a . Ferrite drum core construction.
- b . Magnetically shielded.
- c . Enamelled copper wire : H class
- d . Product weight : 0.04 g ( ref. )
- e . Moisture sensitivity Level 1
- f . Products comply with RoHS' requirements
- g . Halogen free available

Peak Temp : 260°C max.  
 Max. Peak Temp - 5°C : 30sec max.  
 Max time above 217°C : 60sec~150sec max.

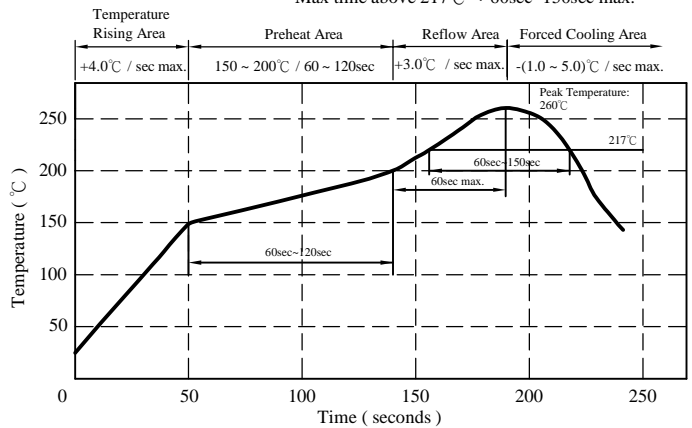

**III . General specification :**

- a . Storage temp. : -40°C ----+125°C
- b . Operating temp. : -40°C ----+125°C  
(Temp. rise included)
- c . Resistance to solder heat : 260°C.10 secs.

AR-001C

# SPECIFICATION FOR APPROVAL

REF. :

PROD. NAME	Shielded SMD Power Inductor	ABC'S DWG NO.	SU3009□□□□L□-□□□		
		REV.	20151214-D	PAGE	2

## IV . Electrical characteristics :

DWG No.	Inductance ( $\mu$ H )	Q ref.	Test Freq. ( Hz )		RDC ( m $\Omega$ )		SRF ( MHz )	Irms ( mA )	Isat ( mA )	Marking
			L	Q	typ.	max.	typ.	typ.		
SU30091R3YL□-□□□	1.3 $\pm$ 30 %	10.0	100k	7.96M	88	115	210	1000	1100	A
SU30092R2YL□-□□□	2.2 $\pm$ 30 %	8.5	100k	7.96M	115	145	150	800	850	B
SU30093R3YL□-□□□	3.3 $\pm$ 30 %	8.0	100k	7.96M	180	225	130	650	720	C
SU30094R7YL□-□□□	4.7 $\pm$ 30 %	9.0	100k	7.96M	230	290	100	480	500	D
SU30096R8YL□-□□□	6.8 $\pm$ 30 %	8.0	100k	7.96M	400	500	85	400	430	E
SU3009100YL□-□□□	10.0 $\pm$ 30 %	8.5	100k	2.52M	610	760	60	280	350	F
SU3009220YL□-□□□	22.0 $\pm$ 30 %	20.0	100k	2.52M	1300	1600	40	220	250	G

- 1). □ : Packaging information : □ Code
- 2). "-□□□" : Reference code
- 3). Electrical specifications at 25°C
- 4). Inductance Test Freq. : 100kHz / 0.1V
- 5). Isat base on  $\Delta L / L_{0A} = 35\%$  typ.
- 6). Irms base on Temp. rise 40°C typ.

@ Inductance VS. DC Current Curve :

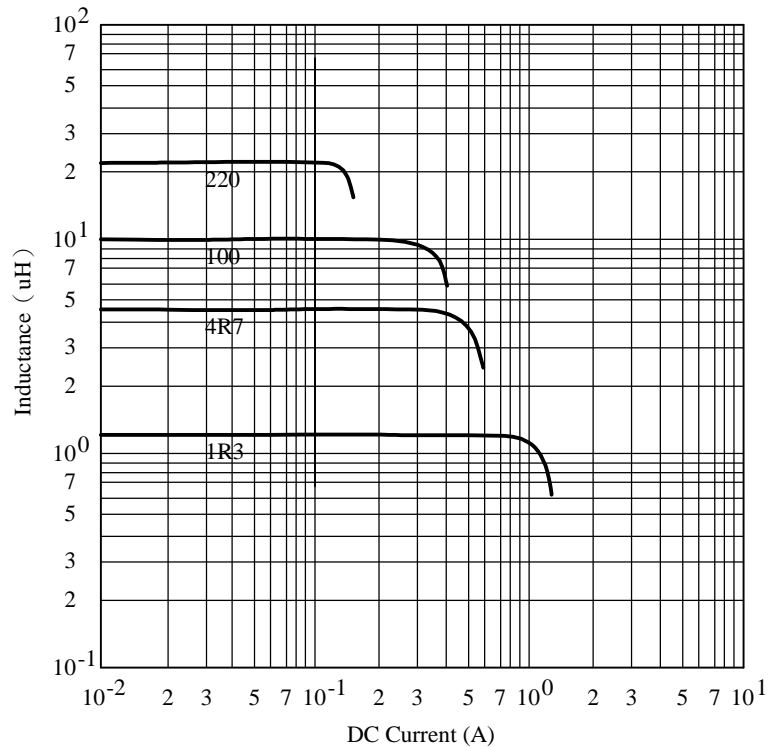

AR-001C

# SPECIFICATION FOR APPROVAL

REF. :

PROD. NAME	Shielded SMD Power Inductor	ABC'S DWG NO.		SU3009□□□□L□-□□□	
		REV.	20151214-D	PAGE	3

**V . Packaging information :**

( 1 ) Configuration

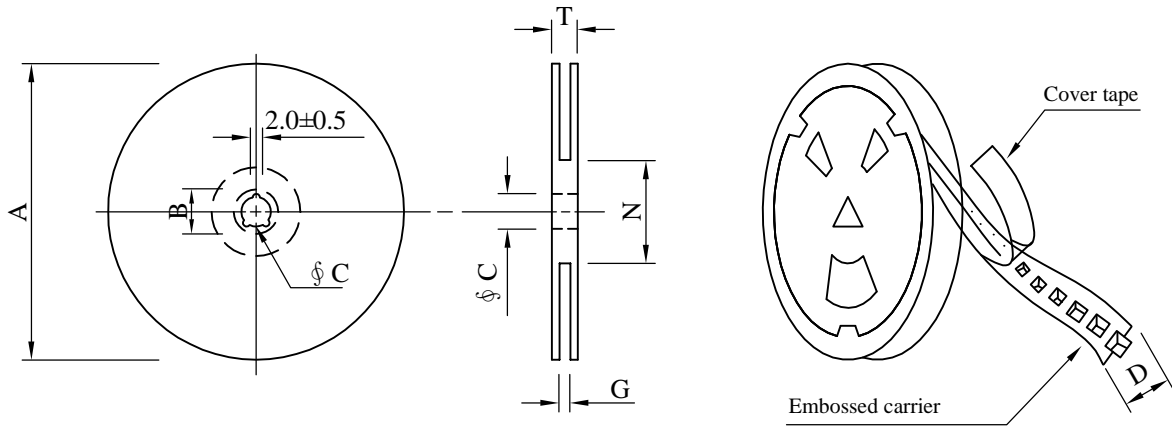

※Carrier tape width : D

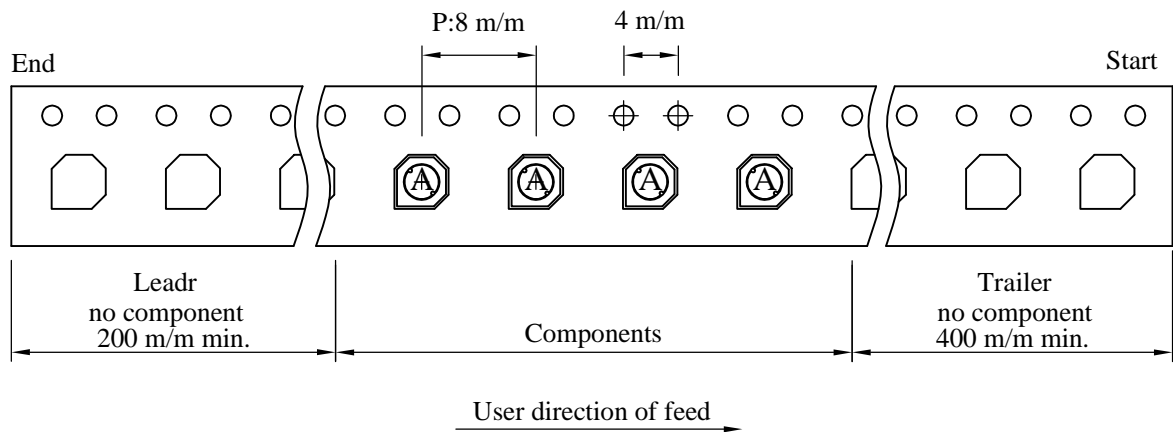

( 2 ) Dimensions

Unit:m/m

Style	A	B	C	D	G	N	T
07 - 12	178	21±0.8	13	12	14 +0	50 -0	16.5

( 3 ) Q'TY & G.W. Per package

Code	Inner : Reel			Outer : Carton		
	Q'TY (pcs)	G.W. (gw)	Style	Q'TY (pcs)	G.W. (Kg)	Size (cm)
B	1,500	180	07 - 12	60,000	8.5	42 x 41 x 24

AR-001C

# SPECIFICATION FOR APPROVAL

REF. :

PROD. NAME	Shielded SMD Power Inductor	ABC'S DWG NO.	SU3009□□□□L□-□□□		
		REV.	20151214-D	PAGE	4

## VI . Reliability test :

Item	Reference documents	Test Condition	Test Specification
1.High Temperature Exposure	MIL-STD-202 Method 108	1.Temperature: 125±2℃ 2.Time:96±2 hours.	1.No mechanical or electrical damage. 2.Inductance shall not change more than ±20%.
2.Temperature Cycling	JESD22-A 104	1.Temperature: -40℃ ~ +125℃ 2.Number of cycle:100 cycle 3.Dwell time:30 minutes	1.No mechanical or electrical damage. 2.Inductance shall not change more than ±20%.
3.Biased Humidity Test	MIL-STD-202 Method 103	1.Temperature : 85±2 ℃ 2.Humidity: 85% RH. 3.Time:96±2 Hours	1.No mechanical or electrical damage. 2.Inductance shall not change more than ±20%.
4.Operational Life	JESD22-A 108	1.Temperature: 125℃ (Temp. rise included) 2.Time:96±2 hours. 3.Rated current	1.No mechanical or electrical damage. 2.Inductance shall not change more than ±20%.
5.External Visual	JESD22-B 101 & MIL-STD-883 Method 2009	Inspect product constructions, marking and workmanship.	1.No pollution on the surface of products. 2.Clear marking. 3.No crack.
6.Physical Dimensions	JESD22-B 100	Verify physical dimensions to the applicable product detail specification.	Per product specification standard
7.Resistance to solvents	MIL-STD-202 Method 215	Immerse into solvent for 3±0.5 minutes & brush 10 times for 3 cycles.	1.No body change in apperarence. 2.No marking blurred. 3.Inductance shall not change more than ±20%.
8.Vibration Test	MIL-STD-202 Method 204	1.Frequency and Amplitued : 10-2000-10 Hz, 1.5 mm. 2.Direction:X, Y, Z 3.Test duration:2 hours for each direction, 6 hours in total.	1.No mechanical or electrical damage. 2.Inductance shall not change more than ±20%.
9.Resistance To Soldering Heat Test	MIL-STD-202 Method 210 & J-STD020D.1	1.Highest temperature : 260±5℃. 2.Time ( temp. ≥ 217℃ ) : 60~150 Second. 3.IR reflow times : 3 times.	1.No mechanical or electrical damage. 2.Inductance shall not change more than ±20%.
10.Saturation Current	JIS C 6436 & User SPEC.	1.Applied rated current for 5 second. 2.Saturation current	Inductance shall not drop more than 35% typ.
11.Over load	JIS C 6436 & User SPEC.	1.Applied one and half rated current for a period of 5 minutes. 2.Rated current	No electrical or mechanical damage
12.Temperature Rise Current	JIS C 6436 & User SPEC.	1.Applied rated current for 10 minutes. 2.Temperature measure by digital surface thermometer. 3.Irms current	Surface temperature rise is less than 40℃ typ.
13.Solderability Test	J-STD-002 & JESD22-B 102	1.Baking in pre-testing : 150±5℃ / 16Hours±30 min. 2.Peak temperature : 240±5℃ 3.Time ( temp. ≥ 217℃ ) : 60~150 second. 4.IR reflow times : 1 times.	More than 95% soldering coverage min on terminations.
14.Electrical Characteriazation	MIL-STD-202 Method 304 & User SPEC.	1.Operating temperature : -40℃~125℃ 2.Room temperature : 25℃.	1.No mechanical or electrical damage. 2.Inductance shall not change more than ±20%.
15.Drop	CNS-C6354 & GB/T 2423.8	1.Products shall be mounted on SPEC. PCB and dropped down from a height of 1m 2.Drop total time : 6 time (Every side of sample drop 2 time)	1. Adhesion on PCB shall be enough. 2. Product appearance shall not break. 3. No electrical damage.
16.Terminal Strength Test	IEC 60068-2-21	1.Apply push force to samples mounted on PCB. 2.Force of 1.8 kg for 60±1 seconds.	After test, inductors shall be no mechanical damage.

AR-001C