

SPECIFICATION FOR APPROVAL

REF. :

PROD. NAME	Shielded SMD Power Inductor	ABC'S DWG NO.	SS6028□□□□L□-□□□		
		REV.	20150918-D	PAGE	1

I . Configuration and dimensions :

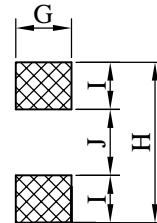
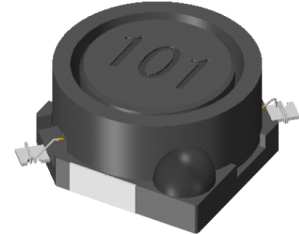
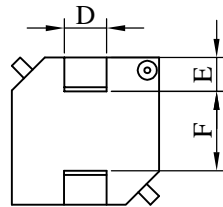
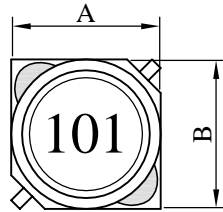

(PCB Pattern Suggestion)

Unit : m/m

A	B	C	D	E	F	G	H	I	J
6.00 ±0.3	6.00 ±0.3	2.80 ±0.3	2.00 ±0.3	1.90 typ.	2.20 ref.	2.40 ref.	6.70 ref.	2.30 ref.	2.10 ref.

II . Description :

- a . Ferrite drum core construction.
- b . Magnetically shielded.
- c . Enamelled copper wire : F class
- d . Product weight : 0.21g (ref.)
- e . Moisture sensitivity Level 1
- f . Products comply with RoHS' requirements
- g . Halogen free available

III . General specification :

- a . Storage temp. : -40°C ----+125°C
- b . Operating temp. : -40°C ----+125°C
(Temp. rise included)
- c . Resistance to solder heat : 250°C .10 secs.

Peak Temp : 250°C max.
Max. Peak Temp - 5°C : 30sec max.
Max time above 217°C : 60sec~150sec max.

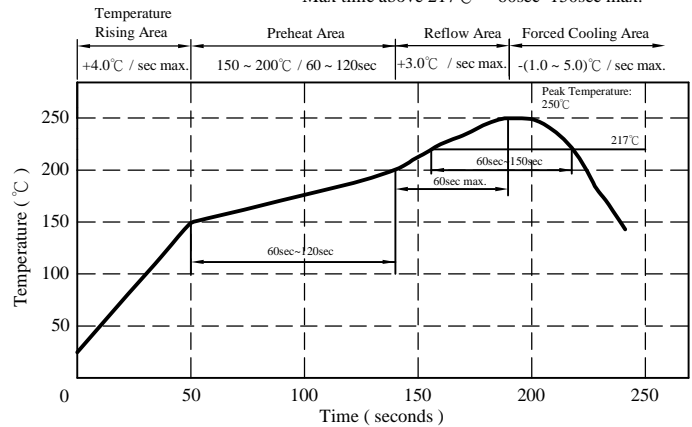

AR-001C

SPECIFICATION FOR APPROVAL

REF. :

PROD. NAME	Shielded SMD Power Inductor	ABC'S DWG NO.	SS6028□□□□L□-□□□		
		REV.	20150918-D	PAGE	2

IV . Electrical characteristics :

DWG No.	Inductance (uH)	Test Freq. (Hz)	RDC (Ω) max.	I _{rms} (A)	I _{sat} (A)
SS60281R0ML□-□□□	1.0±20%	1k	0.022	3.80	3.00
SS60281R5ML□-□□□	1.5±20%	1k	0.025	3.20	2.50
SS60282R2ML□-□□□	2.2±20%	1k	0.032	3.00	2.20
SS60283R3ML□-□□□	3.3±20%	1k	0.044	1.92	1.55
SS60284R7ML□-□□□	4.7±20%	1k	0.050	1.80	1.35
SS60286R8ML□-□□□	6.8±20%	1k	0.070	1.45	1.20
SS6028100ML□-□□□	10.0±20%	1k	0.105	1.20	1.00
SS6028150ML□-□□□	15.0±20%	1k	0.140	1.00	0.80
SS6028220ML□-□□□	22.0±20%	1k	0.220	0.80	0.65
SS6028330ML□-□□□	33.0±20%	1k	0.280	0.65	0.55
SS6028470ML□-□□□	47.0±20%	1k	0.380	0.55	0.48
SS6028680ML□-□□□	68.0±20%	1k	0.600	0.45	0.38
SS6028101ML□-□□□	100.0±20%	1k	0.840	0.38	0.31
SS6028151ML□-□□□	150.0±20%	1k	1.200	0.30	0.26
SS6028221ML□-□□□	220.0±20%	1k	1.700	0.25	0.22
SS6028331ML□-□□□	330.0±20%	1k	2.450	0.20	0.17
SS6028471ML□-□□□	470.0±20%	1k	3.600	0.17	0.14
SS6028681ML□-□□□	680.0±20%	1k	5.400	0.13	0.11
SS6028102ML□-□□□	1000.0±20%	1k	8.200	0.11	0.09

- 1). □: Packaging information : □ Code
- 2). "- □□□ " : Reference code
- 3). Electrical specifications at 25°C
- 4). I_{rms} base on Temp. rise 40°C max.
- 5). I_{sat} base on ΔL/L0A=25% max.
- 6). Inductance test condition 1kHz/0.5V

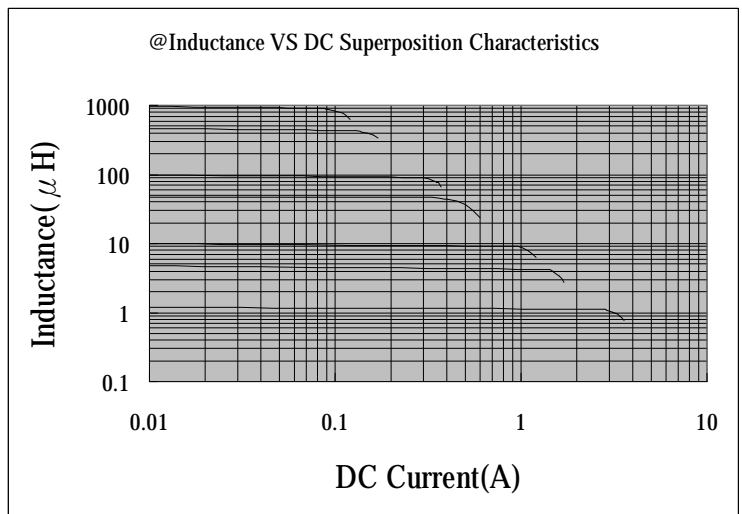

AR-001C

SPECIFICATION FOR APPROVAL

REF. :

PROD. NAME	Shielded SMD Power Inductor	ABC'S DWG NO.	SS6028□□□□L□-□□□		
		REV.	20150918-D	PAGE	3

V . Packaging information :

(1) Configuration

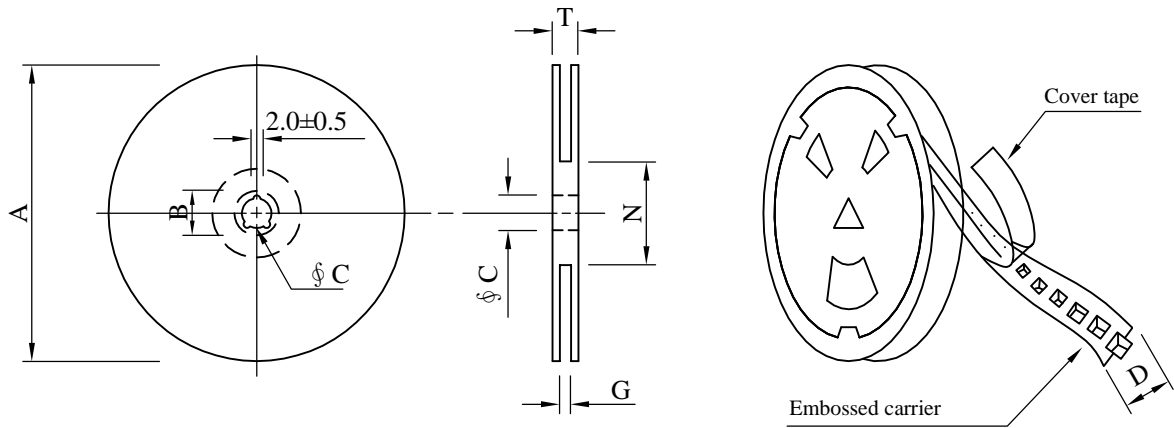

※Carrier tape width : D

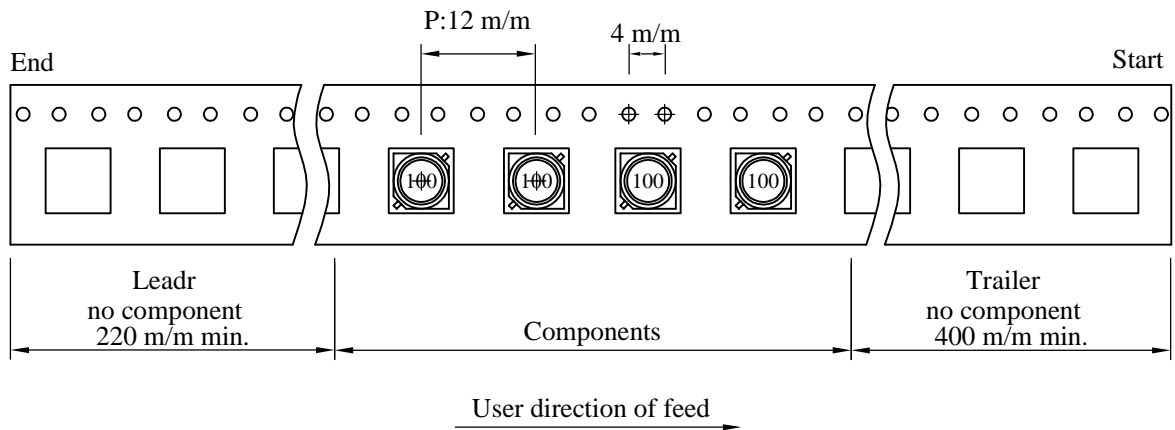

(2) Dimensions

Unit:m/m

Style	A	B	C	D	G	N	T
07 - 16	178	21±0.8	13	16	18 ⁺⁰	50 ⁻⁰	20.5
13 - 16	330	21±0.8	13±0.5	16	18 ⁺⁰	50 ⁻⁰	22.4

(3) Q'TY & G.W. Per package

Code	Inner : Reel			Outer : Carton		
	Q'TY (pcs)	G.W. (gw)	Style	Q'TY (pcs)	G.W. (Kg)	Size (cm)
B	400	230	07 - 16	12,000	8.4	42 x 41 x 24
C	1,500	850	13 - 16	9,000	6.4	38 x 37 x 22

AR-001C

SPECIFICATION FOR APPROVAL

REF. :

PROD. NAME	Shielded SMD Power Inductor	ABC'S DWG NO.	SS6028□□□□L□-□□□		
		REV.	20150918-D	PAGE	4

VI . Reliability test :

Item	Reference documents	Test Condition	Test Specification
1.High Temperature Exposure	MIL-STD-202 Method 108	1.Temperature: 125±2℃ 2.Time:96±2 hours.	1.No mechanical or electrical damage. 2.Inductance shall not change more than ±20%.
2.Temperature Cycling	JESD22-A 104	1.Temperature: -40℃ ~ +125℃ 2.Number of cycle:100 cycle 3.Dwell time:30 minutes	1.No mechanical or electrical damage. 2.Inductance shall not change more than ±20%.
3.Biased Humidity Test	MIL-STD-202 Method 103	1.Temperature : 85±2 ℃ 2.Humidity: 85% RH. 3.Time:96±2 Hours	1.No mechanical or electrical damage. 2.Inductance shall not change more than ±20%.
4.Operational Life	JESD22-A 108	1.Temperature: 125℃ (Temp. rise included) 2.Time:96±2 hours. 3.Rated current	1.No mechanical or electrical damage. 2.Inductance shall not change more than ±20%.
5.External Visual	JESD22-B 101 & MIL-STD-883 Method 2009	Inspect product constructions, marking and workmanship.	1.No pollution on the surface of products. 2.Clear marking. 3.No crack.
6.Physical Dimensions	JESD22-B 100	Verify physical dimensions to the applicable product detail specification.	Per product specification standard
7.Resistance to solvents	MIL-STD-202 Method 215	Immerse into solvent for 3±0.5 minutes & brush 10 times for 3 cycles.	1.No body change in apperance. 2.No marking blurred. 3.Inductance shall not change more than ±20%.
8.Vibration Test	MIL-STD-202 Method 204	1.Frequency and Amplitued : 10-2000-10 Hz, 1.5 mm. 2.Direction:X, Y, Z 3.Test duration:2 hours for each direction, 6 hours in total.	1.No mechanical or electrical damage. 2.Inductance shall not change more than ±20%.
9.Resistance To Soldering Heat Test	MIL-STD-202 Method 210 & J-STD020D.1	1.Highest temperature : 250±5℃. 2.Time (temp. ≥ 217℃) : 60~150 Second. 3.IR reflow times : 3 times.	1.No mechanical or electrical damage. 2.Inductance shall not change more than ±20%.
10.Saturation Current	JIS C 6436 & User SPEC.	1.Applied rated current for 5 second. 2.Saturation current	Inductance shall not drop more than 25% max.
11.Over load	JIS C 6436 & User SPEC.	1.Applied one and half rated current for a period of 5 minutes. 2.Rated current	No electrical or mechanical damage
12.Temperature Rise Current	JIS C 6436 & User SPEC.	1.Applied rated current for 10 minutes. 2.Temperature measure by digital surface thermometer. 3.Irms current	Surface temperature rise is less than 40℃ max.
13.Solderability Test	J-STD-002 & JESD22-B 102	1.Baking in pre-testing : 150±5℃ / 16Hours±30 min. 2.Peak temperature : 240±5℃ 3.Time (temp. ≥ 217℃) : 60~150 second. 4.IR reflow times : 1 times.	More than 95% soldering coverage min on terminations.
14.Electrical Characteriazation	MIL-STD-202 Method 304 & User SPEC.	1.Operating temperature : -40℃~125℃ 2.Room temperature : 25℃.	1.No mechanical or electrical damage. 2.Inductance shall not change more than ±20%.
15.Drop	CNS-C6354 & GB/T 2423.8	1.Products shall be mounted on SPEC. PCB and dropped down from a height of 1m 2.Drop total time : 6 time (Every side of sample drop 2 time)	1. Adhesion on PCB shall be enough. 2. Product appearance shall not break. 3. No electrical damage.
16.Terminal Strength Test	IEC 60068-2-21	1.Apply push force to samples mounted on PCB. 2.Force of 1.8 kg for 60±1 seconds.	After test, inductors shall be no mechanical damage.

AR-001C

