

SPECIFICATION FOR APPROVAL

REF. :

PROD. NAME	Shielded SMD Power Inductor	ABC'S DWG NO.	SS1280□□□□F□-□□□		
		REV.	20160901-D	PAGE	1

I . Configuration and dimensions :

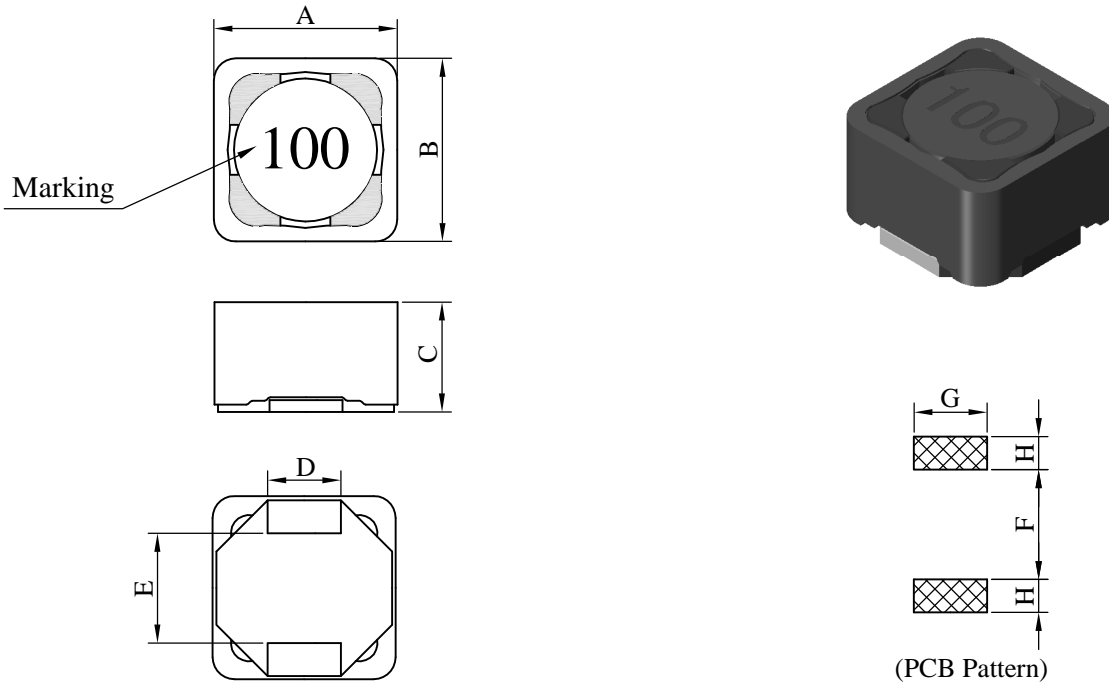

Unit : m/m

A	B	C	D	E	F	G	H
12.50 ±0.3	12.50 ±0.3	7.50 ±0.5	5.00 ±0.3	7.00 typ.	6.80 ref.	5.40 ref.	2.90 ref.

II . Description :

- a . Ferrite drum core construction.
- b . Magnetically shielded.
- c . Enamelled copper wire : F class
- d . Product weight : 4.60 g (ref.)
- e . Moisture sensitivity Level 1
- f . Products comply with RoHS' requirements
- g . Halogen free available

III . General specification :

- a . Storage temp. : -40°C ----+125°C
- b . Operating temp. : -40°C ----+125°C
(Temp. rise included)
- c . Resistance to solder heat : 245°C .10 secs.

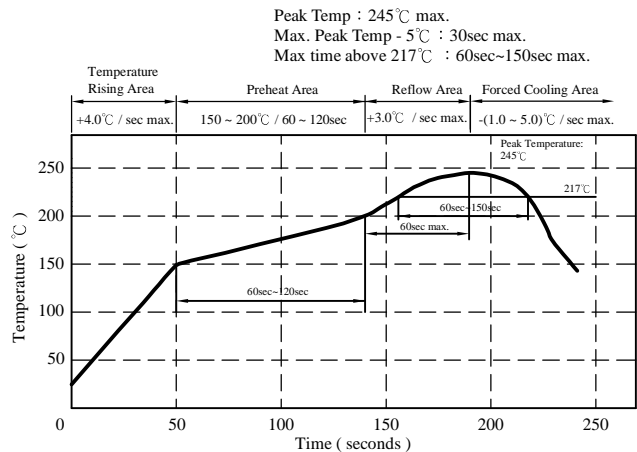

AR-001C

SPECIFICATION FOR APPROVAL

REF. :

PROD. NAME	Shielded SMD Power Inductor	ABC'S DWG NO.	SS1280□□□□F□-□□□		
		REV.	20160901-D	PAGE	2

IV . Electrical characteristics :

DWG No.	Inductance (μH)	Q ref.	Test Freq. (MHz)	SRF (MHz) typ.	RDC (mΩ) max.	I _{rms} (A) typ.	I _{sat} (A) typ.
SS12801R1YF□-□□□	1.1 ± 30%	26	7.96	85	6.5	10.20	14.00
SS12801R4YF□-□□□	1.4 ± 30%	24	7.96	80	9.8	9.80	12.00
SS12802R4YF□-□□□	2.4 ± 30%	20	7.96	45	10.0	9.20	10.50
SS12803R3YF□-□□□	3.3 ± 30%	20	7.96	40	12.0	8.80	9.80
SS12804R5YF□-□□□	4.5 ± 30%	20	7.96	34	13.5	8.50	9.00
SS12804R7YF□-□□□	4.7 ± 30%	22	7.96	30	15.5	8.20	8.80
SS12805R6YF□-□□□	5.6 ± 30%	20	7.96	24	16.0	8.00	8.50
SS12806R8YF□-□□□	6.8 ± 30%	20	7.96	22	18.5	7.60	8.00
SS12807R5YF□-□□□	7.5 ± 30%	16	7.96	21	17.5	6.40	7.00
SS12808R2YF□-□□□	8.2 ± 30%	22	2.52	20	20.5	6.20	6.80
SS1280100MF□-□□□	10.0 ± 20%	24	2.52	17	19.5	6.00	6.60
SS1280120MF□-□□□	12.0 ± 20%	26	2.52	15	28.0	5.60	6.30
SS1280150MF□-□□□	15.0 ± 20%	26	2.52	13	28.5	5.20	5.00
SS1280180MF□-□□□	18.0 ± 20%	24	2.52	12	35.0	4.80	4.60
SS1280220MF□-□□□	22.0 ± 20%	20	2.52	11	38.6	4.30	4.10
SS1280270MF□-□□□	27.0 ± 20%	26	2.52	10	52.0	3.90	3.70
SS1280330MF□-□□□	33.0 ± 20%	28	2.52	9.5	57.0	3.50	3.30
SS1280390MF□-□□□	39.0 ± 20%	24	2.52	8.5	70.0	3.20	3.10
SS1280470MF□-□□□	47.0 ± 20%	24	2.52	7.5	80.0	2.90	2.80
SS1280560MF□-□□□	56.0 ± 20%	24	2.52	7.0	100.0	2.60	2.50
SS1280680MF□-□□□	68.0 ± 20%	20	2.52	6.5	120.0	2.40	2.30
SS1280820MF□-□□□	82.0 ± 20%	20	2.52	5.0	130.0	2.30	2.20
SS1280101MF□-□□□	100.0 ± 20%	18	0.796	4.5	150.0	2.10	2.00
SS1280121KF□-□□□	120.0 ± 10%	16	0.796	4.3	200.0	1.95	1.95
SS1280151KF□-□□□	150.0 ± 10%	24	0.796	4.1	270.0	1.85	1.90
SS1280181KF□-□□□	180.0 ± 10%	24	0.796	4.0	300.0	1.75	1.88
SS1280221KF□-□□□	220.0 ± 10%	24	0.796	3.4	400.0	1.60	1.70
SS1280271KF□-□□□	270.0 ± 10%	20	0.796	3.1	450.0	1.20	1.60
SS1280331KF□-□□□	330.0 ± 10%	18	0.796	2.9	600.0	1.10	1.40
SS1280391KF□-□□□	390.0 ± 10%	20	0.796	2.7	680.0	1.00	1.40
SS1280471KF□-□□□	470.0 ± 10%	20	0.796	2.2	880.0	0.90	1.25
SS1280561KF□-□□□	560.0 ± 10%	20	0.796	2.0	960.0	0.80	1.15
SS1280681KF□-□□□	680.0 ± 10%	26	0.796	1.7	1300.0	0.75	0.97
SS1280821KF□-□□□	820.0 ± 10%	20	0.796	1.4	1500.0	0.70	0.94
SS1280102KF□-□□□	1000.0 ± 10%	40	0.252	1.3	1700.0	0.68	0.80

- | | |
|---|--|
| 1). □ : Packaging information : □ Code | 5). I _{rms} Base on temp rise 40°C typ. |
| 2). "-□□□" : Reference code | 6). I _{sat} Base on ΔL/L0A=25% typ. |
| 3). Electrical specifications at 25°C | |
| 4). Inductance test freq. : 1R1~8R2 : 100kHz / 1V , 100~102 : 1kHz / 1V | |

AR-001C



SPECIFICATION FOR APPROVAL

REF. :

PROD. NAME	Shielded SMD Power Inductor	ABC'S DWG NO.	SS1280□□□□F□-□□□		
		REV.	20160901-D	PAGE	3

V . Curve :

SS12804R7YF□

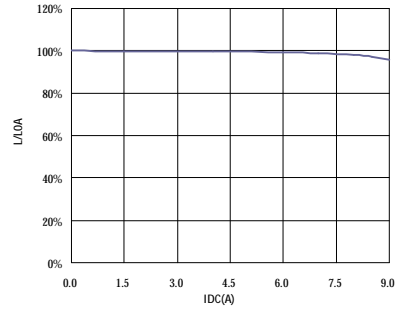
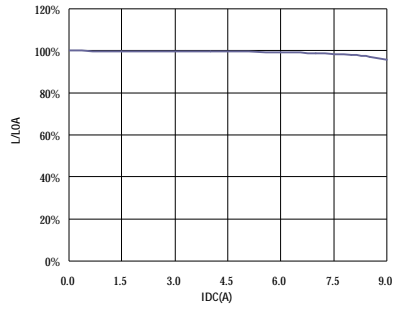

SS1280270MF□

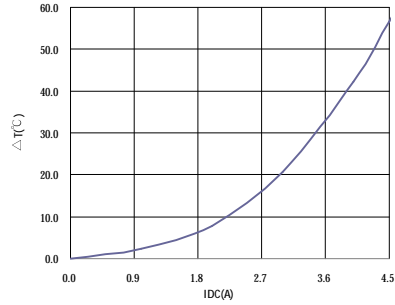
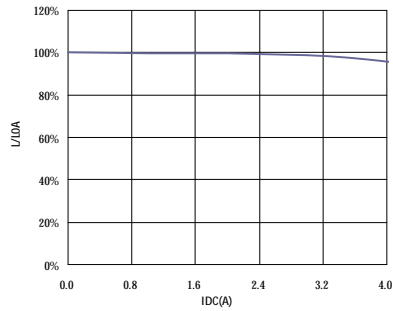

SS1280471KF□

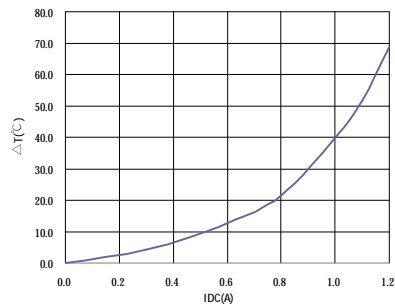
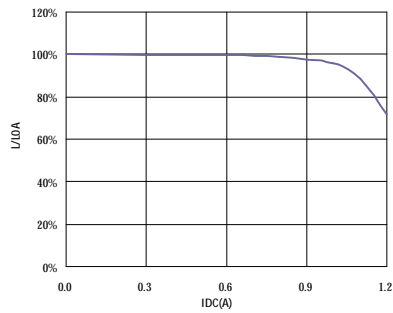

SS1280102KF□

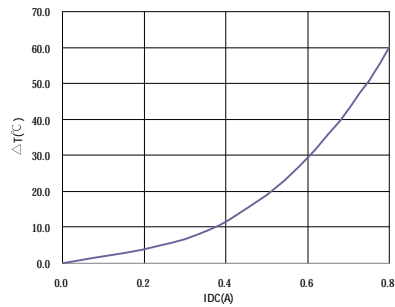
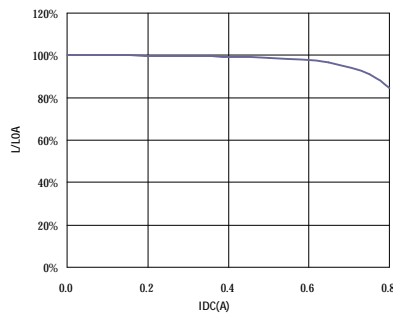

AR-001C

SPECIFICATION FOR APPROVAL

REF. :

PROD. NAME	Shielded SMD Power Inductor	ABC'S DWG NO.	SS1280□□□□F□-□□□		
		REV.	20160901-D	PAGE	4

VI . Packaging information :

(1) Configuration

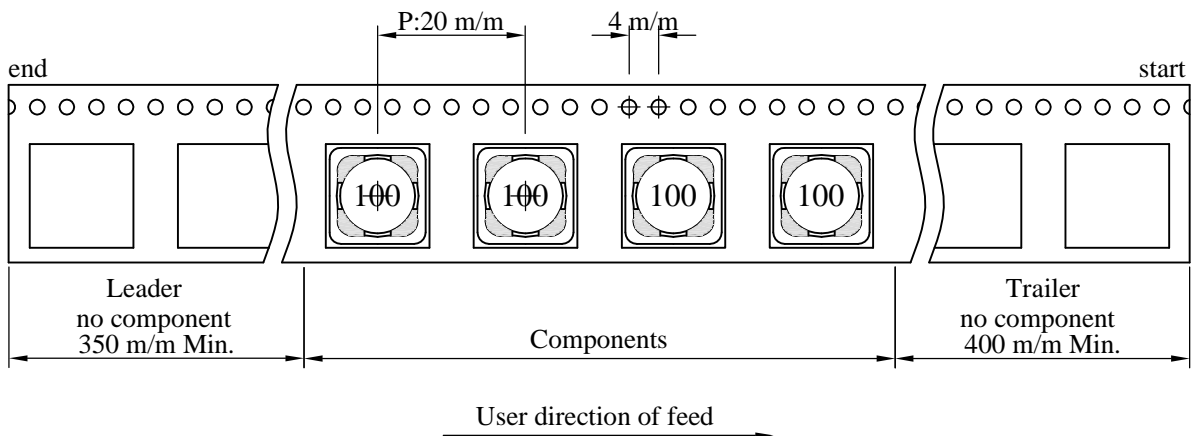
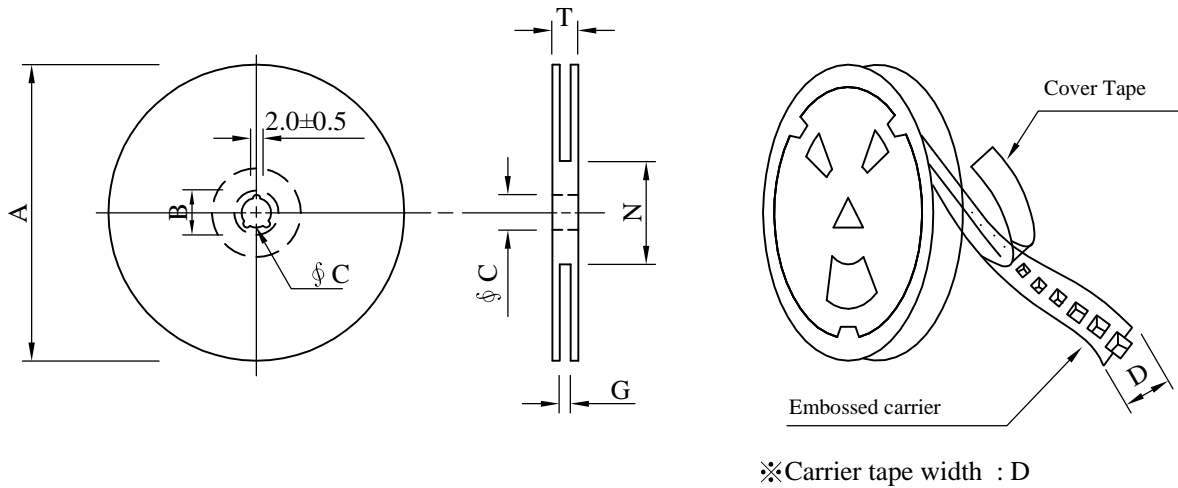

(2) Dimensions

Unit:m/m

Style	A	B	C	D	G	N	T
13 - 24	330	21±0.8	13±0.5	24	26 ⁺⁰	60 ⁻⁰	30.4

(3) Q'TY & G.W. Per package

Code	Inner : Reel			Outer : Carton		
	Q'TY (pcs)	G.W. (gw)	Style	Q'TY (PCS)	G.W. (Kg)	Size (cm)
B	400	2160	13 - 24	1,600	9.9	38 x 37 x 22

AR-001C

SPECIFICATION FOR APPROVAL

REF. :

PROD. NAME	Shielded SMD Power Inductor	ABC'S DWG NO.	SS1280□□□□F□-□□□		
		REV.	20160901-D	PAGE	5

VI . Drawing number expression :

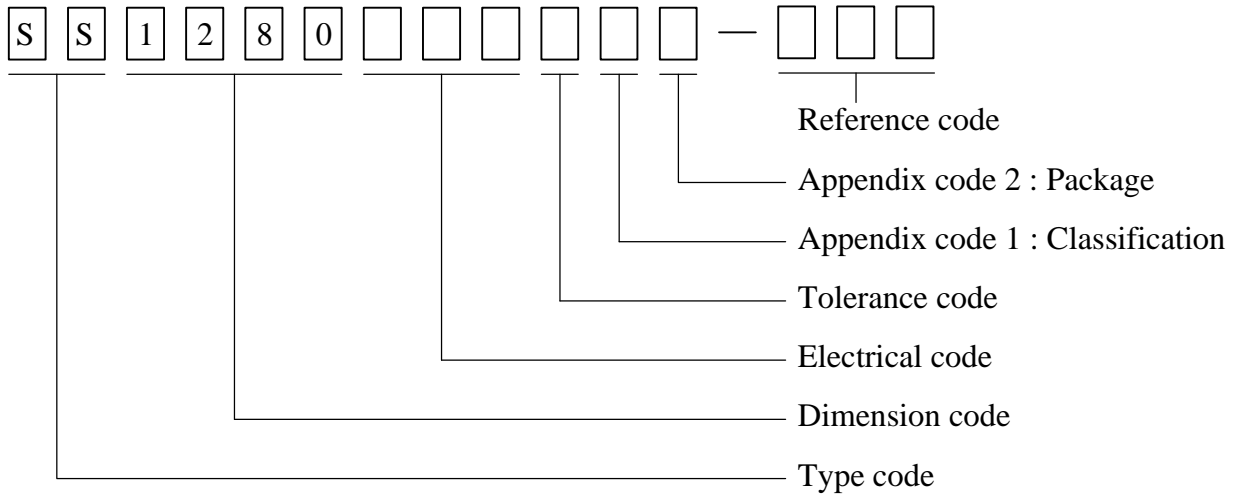

Appendix code 1 : Product Classification

Appendix code 2 : Package Information

Code	Inner package	Cover tape	Carrier tape	Bag	Package Q'TY	Remark
B	T/R (Reel package)	UCT	Antistatic	Antistatic	400 pcs	

AR-001C

SPECIFICATION FOR APPROVAL

REF. :

PROD. NAME	Shielded SMD Power Inductor	ABC'S DWG NO.	SS1280□□□□F□-□□□		
		REV.	20160901-D	PAGE	6

VIII . Reliability test :

Item	Reference documents	Test Condition	Test Specification
1.High Temperature Exposure	MIL-STD-202 Method 108	1.Temperature: 125±2℃ 2.Time:96±2 hours.	1.No mechanical or electrical damage. 2.Inductance shall not change more than ±20%.
2.Temperature Cycling	JESD22-A 104	1.Temperature: -40℃ ~ +125℃ 2.Number of cycle:100 cycles 3.Dwell time:30 minutes	1.No mechanical or electrical damage. 2.Inductance shall not change more than ±20%.
3.Biased Humidity Test	MIL-STD-202 Method 103	1.Temperature : 85±2℃ 2.Humidity: 85% RH. 3.Time:96±2 Hours	1.No mechanical or electrical damage. 2.Inductance shall not change more than ±20%.
4.Operational Life	JESD22-A 108	1.Temperature: 125℃ (Temp. rise included) 2.Time:96±2 hours. 3.Rated current	1.No mechanical or electrical damage. 2.Inductance shall not change more than ±20%.
5.External Visual	JESD22-B 101 & MIL-STD-883 Method 2009	Inspect product constructions, marking and workmanship.	1.No pollution on the surface of products. 2.Clear marking. 3.No crack.
6.Physical Dimensions	JESD22-B 100	Verify physical dimensions to the applicable product detail specification.	Per product specification standard
7.Resistance to solvents	MIL-STD-202 Method 215	Immerse into solvent for 3±0.5 minutes & brush 10 times for 3 cycles.	1.No body change in apperance. 2.No marking blurred. 3.Inductance shall not change more than ±20%.
8.Vibration Test	MIL-STD-202 Method 204	1.Frequency and Amplitud : 10-2000-10 Hz, 1.5 mm. 2.Direction:X, Y, Z 3.Test duration:2 hours for each direction, 6 hours in total.	1.No mechanical or electrical damage. 2.Inductance shall not change more than ±20%.
9.Resistance To Soldering Heat Test	MIL-STD-202 Method 210 & J-STD020D.1	1.Highest temperature : 245±5℃. 2.Time (temp. ≥ 217℃) : 60~150 Seconds. 3.IR reflow times : 3 times.	1.No mechanical or electrical damage. 2.Inductance shall not change more than ±20%.
10.Saturation Current	JIS C 6436 & User SPEC.	1.Applied rated current for 5 seconds. 2.Saturation current	Inductance shall not drop more than 25% typ.
11.Over load	JIS C 6436 & User SPEC.	1.Applied one and half rated current for a period of 5 minutes. 2.Rated current	No electrical or mechanical damage
12.Temperature Rise Current	JIS C 6436 & User SPEC.	1.Applied rated current for 10 minutes. 2.Temperature measure by digital surface thermometer. 3.Irms current	Surface temperature rise is less than 40℃ typ.
13.Solderability Test	J-STD-002 & JESD22-B 102	1.Baking in pre-testing : 150±5℃ / 16Hours±30 min. 2.Peak temperature : 240±5℃ 3.Time (temp. ≥ 217℃) : 60~150 seconds. 4.IR reflow times : 1 time.	More than 95% soldering coverage min on terminations.
14.Electrical Characteriazation	MIL-STD-202 Method 304 & User SPEC.	1.Operating temperature : -40℃~125℃ 2.Room temperature : 25℃.	1.No mechanical or electrical damage. 2.Inductance shall not change more than ±20%.
15.Drop	CNS-C6354 & GB/T 2423.8	1.Products shall be mounted on SPEC. PCB and dropped down from a height of 1m 2.Drop total time : 6 time (Every side of sample drop 2 times)	1. Adhesion on PCB shall be enough. 2. Product appearance shall not break. 3. No electrical damage.
16.Terminal Strength Test	IEC 60068-2-21	1.Apply push force to samples mounted on PCB. 2.Force of 1.8 kg for 60±1 seconds.	After test, inductors shall be no mechanical damage.

AR-001C