

SPECIFICATION FOR APPROVAL

REF. :

PROD. NAME	Shielded SMD Power Inductor	ABC'S DWG NO.	SS1278□□□□L□-□□□		
		REV.	20160901-D	PAGE	1

I . Configuration and dimensions :

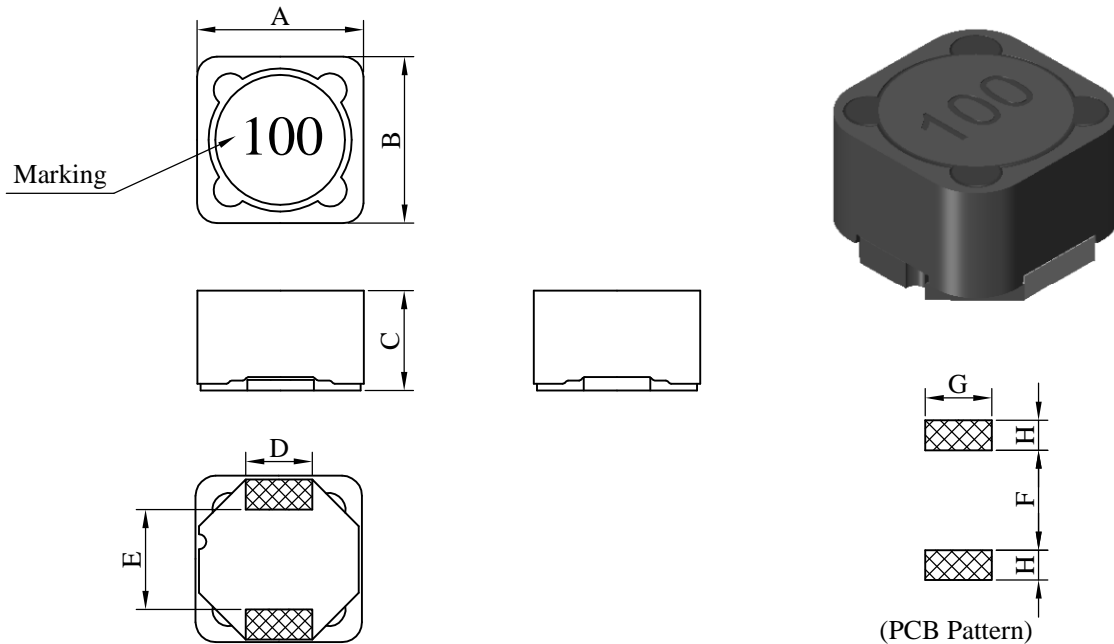

Unit : m/m

A	B	C	D	E	F	G	H
12.00 ±0.3	12.00 ±0.3	8.00 max.	5.00 typ.	5.70 typ.	4.50 ref.	5.50 ref.	4.00 ref.

II . Description :

- a . Ferrite drum core construction.
- b . Magnetically shielded.
- c . Enamelled copper wire : F & H class
- d . Product weight : 4.25g (ref.)
- e . Moisture sensitivity Level 1
- f . Products comply with RoHS' requirements
- g . Halogen free available

III . General specification :

- a . Storage temp. : -40°C ----+125°C
- b . Operating temp. : -40°C----+125°C
(Temp. rise included)
- c . Resistance to solder heat : 245°C .10 secs.

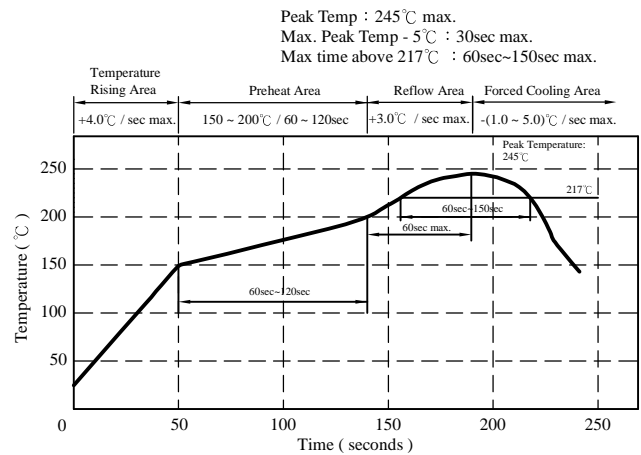

AR-001C

SPECIFICATION FOR APPROVAL

REF. :

PROD. NAME	Shielded SMD Power Inductor	ABC'S DWG NO.	SS1278□□□□L□-□□□		
		REV.	20160901-D	PAGE	2

IV . Electrical characteristics :

DWG No.	Inductance (μ H)	SRF (MHz) typ.	RDC (m Ω) max.	Irms (A)	Isat (A)
SS12781R4ML□-□□□	1.4 \pm 20%	80.0	11	10.00	18.00
SS12784R7ML□-□□□	4.7 \pm 20%	30.0	20	6.20	11.00
SS12786R0ML□-□□□	6.0 \pm 20%	21.0	24	6.00	10.00
SS12788R2ML□-□□□	8.2 \pm 20%	20.0	28	5.90	8.50
SS1278100ML□-□□□	10 \pm 20%	17.0	30	5.70	8.00
SS1278120ML□-□□□	12 \pm 20%	15.0	32	5.20	7.50
SS1278150ML□-□□□	15 \pm 20%	13.0	38	4.90	6.80
SS1278180ML□-□□□	18 \pm 20%	12.0	43	4.50	6.30
SS1278220ML□-□□□	22 \pm 20%	11.0	50	4.00	5.70
SS1278270ML□-□□□	27 \pm 20%	10.0	60	3.60	5.00
SS1278330ML□-□□□	33 \pm 20%	9.5	80	3.10	4.70
SS1278390ML□-□□□	39 \pm 20%	8.5	85	3.00	4.60
SS1278470ML□-□□□	47 \pm 20%	7.5	100	2.90	3.80
SS1278560ML□-□□□	56 \pm 20%	7.0	110	2.70	3.50
SS1278680ML□-□□□	68 \pm 20%	6.5	120	2.60	3.20
SS1278820ML□-□□□	82 \pm 20%	5.0	150	2.30	3.00
SS1278101ML□-□□□	100 \pm 20%	4.5	180	2.00	2.60
SS1278121KL□-□□□	120 \pm 10%	4.3	230	1.90	2.50
SS1278151KL□-□□□	150 \pm 10%	4.1	270	1.80	2.20
SS1278181KL□-□□□	180 \pm 10%	4.0	300	1.70	2.00
SS1278221KL□-□□□	220 \pm 10%	3.4	400	1.60	1.80
SS1278271KL□-□□□	270 \pm 10%	3.1	530	1.20	1.60
SS1278331KL□-□□□	330 \pm 10%	2.9	600	1.00	1.50
SS1278391KL□-□□□	390 \pm 10%	2.7	680	1.00	1.30
SS1278471KL□-□□□	470 \pm 10%	2.2	880	0.90	1.20
SS1278561KL□-□□□	560 \pm 10%	2.0	960	0.80	1.10
SS1278681KL□-□□□	680 \pm 10%	1.7	1300	0.75	1.00
SS1278821KL□-□□□	820 \pm 10%	1.4	1500	0.70	0.95
SS1278102KL□-□□□	1000 \pm 10%	1.3	1700	0.68	0.85

- 1). □ : Packaging information : □ Code
- 2). "-□□□" : Reference code
- 3). Electrical specifications at 25°C
- 4). L Test Freq. : 100kHz / 0.1V
- 5). Irms Base on temp rise 40°C typ.
- 6). Isat Base on Δ L/L0A=20% max.

AR-001C

SPECIFICATION FOR APPROVAL

REF. :

PROD. NAME	Shielded SMD Power Inductor	ABC'S DWG NO.	SS1278□□□□L□-□□□		
		REV.	20160901-D	PAGE	3

V . Curve :

SS12781R4ML□

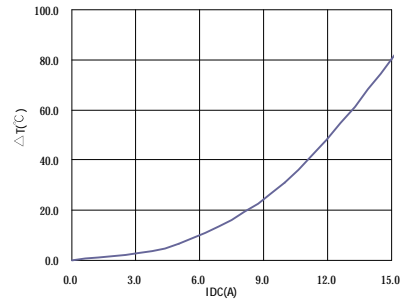
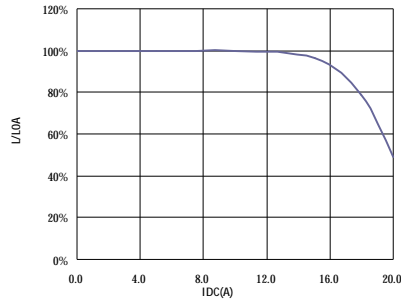

SS1278390ML□

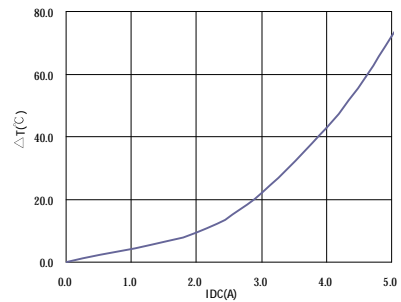
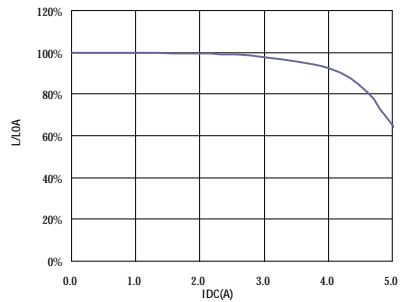

SS1278181KL□

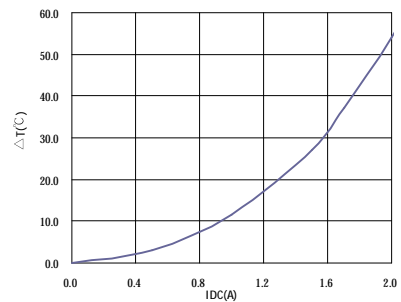
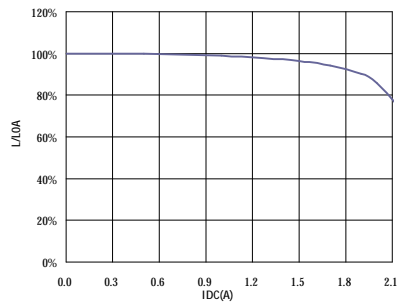

SS1278102KL□

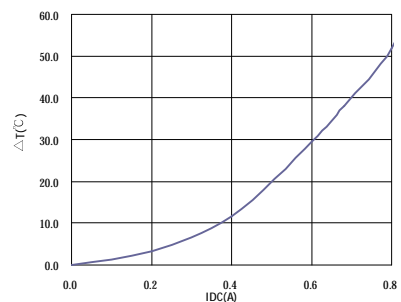
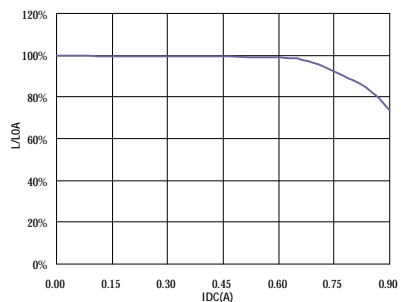

AR-001C

SPECIFICATION FOR APPROVAL

REF. :

PROD. NAME	Shielded SMD Power Inductor	ABC'S DWG NO.	SS1278□□□□L□-□□□		
		REV.	20160901-D	PAGE	4

VI . Packaging information :

(1) Configuration

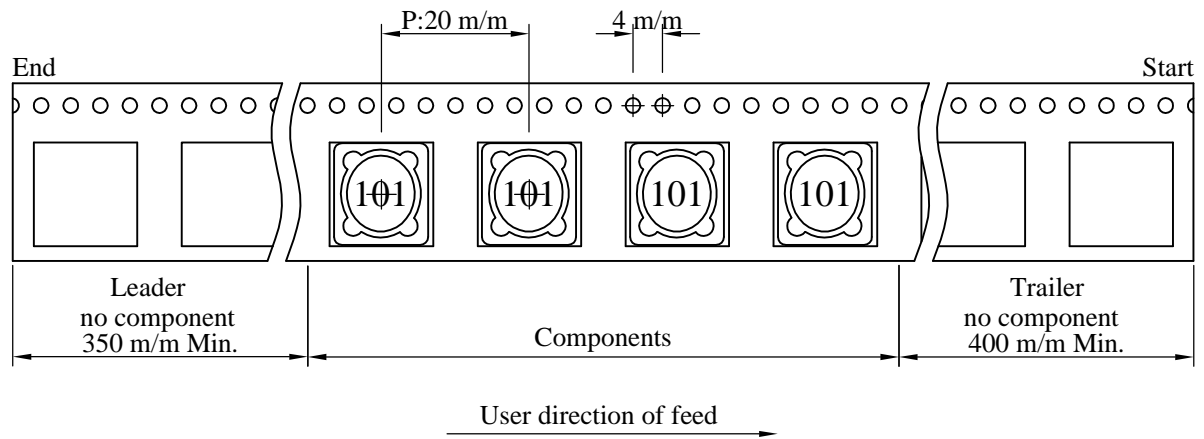
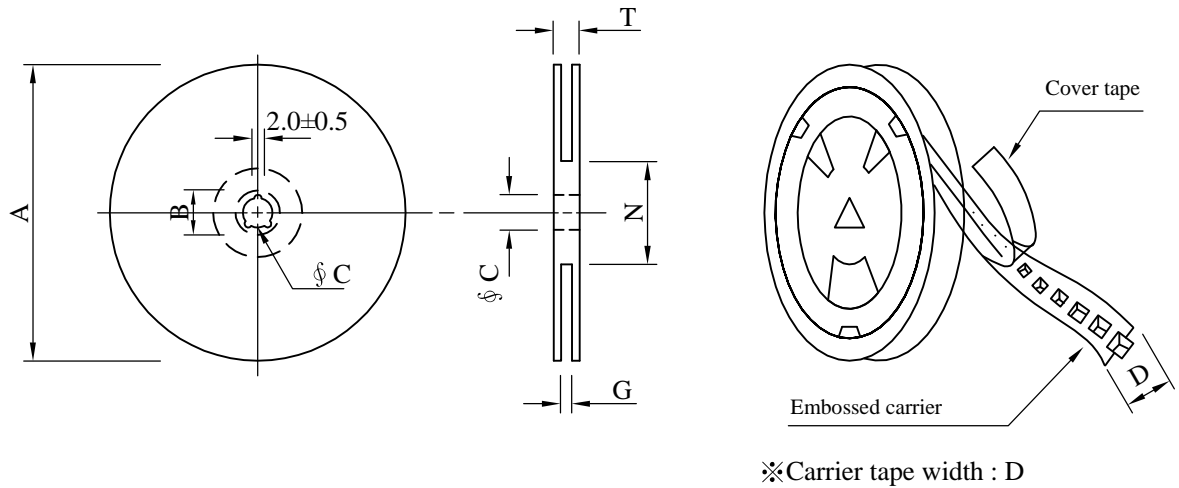

(2) Dimensions

Unit:m/m

Style	A	B	C	D	G	N	T
13 - 24	330	21±0.8	13±0.5	24	26 ⁺⁰	60 ⁻⁰	30.4

(3) Q'TY & G.W. Per package

Code	Inner : Reel			Outer : Carton		
	Q'TY (pcs)	G.W. (gw)	Style	Q'TY (pcs)	G.W. (Kg)	Size (cm)
B	400	2100	13 - 24	1,600	9.7	38 x 37 x 22

AR-001C

SPECIFICATION FOR APPROVAL

REF. :

PROD. NAME	Shielded SMD Power Inductor	ABC'S DWG NO.	SS1278□□□□L□-□□□		
		REV.	20160901-D	PAGE	5

VI . Drawing number expression :

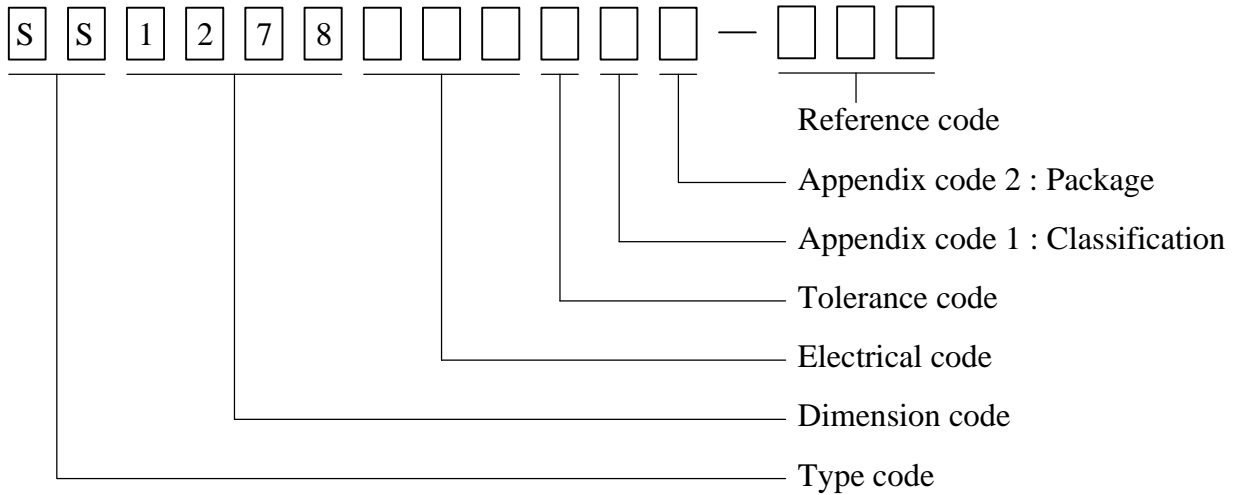

Appendix code 1 : Product Classification

Appendix code 2 : Package Information

Code	Inner package	Cover tape	Carrier tape	Bag	Package Q'TY	Remark
B	T/R (Reel package)	UCT	Antistatic	Antistatic	400 pcs	

AR-001C

SPECIFICATION FOR APPROVAL

REF. :

PROD. NAME	Shielded SMD Power Inductor	ABC'S DWG NO.	SS1278□□□□L□-□□□		
		REV.	20160901-D	PAGE	6

VIII . Reliability test :

Item	Reference documents	Test Condition	Test Specification
1.High Temperature Exposure	MIL-STD-202 Method 108	1.Temperature: 125±2℃ 2.Time:96±2 hours.	1.No mechanical or electrical damage. 2.Inductance shall not change more than ±20%.
2.Temperature Cycling	JESD22-A 104	1.Temperature: -40℃ ~ +125℃ 2.Number of cycle:100 cycles 3.Dwell time:30 minutes	1.No mechanical or electrical damage. 2.Inductance shall not change more than ±20%.
3.Biased Humidity Test	MIL-STD-202 Method 103	1.Temperature : 85±2℃ 2.Humidity: 85% RH. 3.Time:96±2 Hours	1.No mechanical or electrical damage. 2.Inductance shall not change more than ±20%.
4.Operational Life	JESD22-A 108	1.Temperature: 125℃ (Temp. rise included) 2.Time:96±2 hours. 3.Rated current	1.No mechanical or electrical damage. 2.Inductance shall not change more than ±20%.
5.External Visual	JESD22-B 101 & MIL-STD-883 Method 2009	Inspect product constructions, marking and workmanship.	1.No pollution on the surface of products. 2.Clear marking. 3.No crack.
6.Physical Dimensions	JESD22-B 100	Verify physical dimensions to the applicable product detail specification.	Per product specification standard
7.Resistance to solvents	MIL-STD-202 Method 215	Immerse into solvent for 3±0.5 minutes & brush 10 times for 3 cycles.	1.No body change in appearance. 2.No marking blurred. 3.Inductance shall not change more than ±20%.
8.Vibration Test	MIL-STD-202 Method 204	1.Frequency and Amplitud : 10-2000-10 Hz, 1.5 mm. 2.Direction:X, Y, Z 3.Test duration:2 hours for each direction, 6 hours in total.	1.No mechanical or electrical damage. 2.Inductance shall not change more than ±20%.
9.Resistance To Soldering Heat Test	MIL-STD-202 Method 210 & J-STD020D.1	1.Highest temperature : 245±5℃ 2.Time (temp. ≥ 217℃) : 60~150 Seconds. 3.IR reflow times : 3 times.	1.No mechanical or electrical damage. 2.Inductance shall not change more than ±20%.
10.Saturation Current	JIS C 6436 & User SPEC.	1.Applied rated current for 5 seconds. 2.Saturation current	Inductance shall not drop more than 20% max.
11.Over load	JIS C 6436 & User SPEC.	1.Applied one and half rated current for a period of 5 minutes. 2.Rated current	No electrical or mechanical damage
12.Temperature Rise Current	JIS C 6436 & User SPEC.	1.Applied rated current for 10 minutes. 2.Temperature measure by digital surface thermometer. 3.Irms current	Surface temperature rise is less than 40℃ typ.
13.Solderability Test	J-STD-002 & JESD22-B 102	1.Baking in pre-testing : 150±5℃ / 16Hours±30 min. 2.Peak temperature : 240±5℃ 3.Time (temp. ≥ 217℃) : 60~150 seconds. 4.IR reflow times : 1 time.	More than 95% soldering coverage min on terminations.
14.Electrical Characteriazation	MIL-STD-202 Method 304 & User SPEC.	1.Operating temperature : -40℃~125℃ 2.Room temperature : 25℃.	1.No mechanical or electrical damage. 2.Inductance shall not change more than ±20%.
15.Drop	CNS-C6354 & GB/T 2423.8	1.Products shall be mounted on SPEC. PCB and dropped down from a height of 1m 2.Drop total time : 6 times (Every side of sample drop 2 times)	1. Adhesion on PCB shall be enough. 2. Product appearance shall not break. 3. No electrical damage.
16.Terminal Strength Test	IEC 60068-2-21	1.Apply push force to samples mounted on PCB. 2.Force of 1.8 kg for 60±1 seconds.	After test, inductors shall be no mechanical damage.

AR-001C