

SPECIFICATION FOR APPROVAL

REF. :

PROD. NAME	Shielded SMD Power Inductor	ABC'S DWG NO.	SS1208□□□□T□-□□□		
		REV.	20160901-D	PAGE	1

I . Configuration and dimensions :

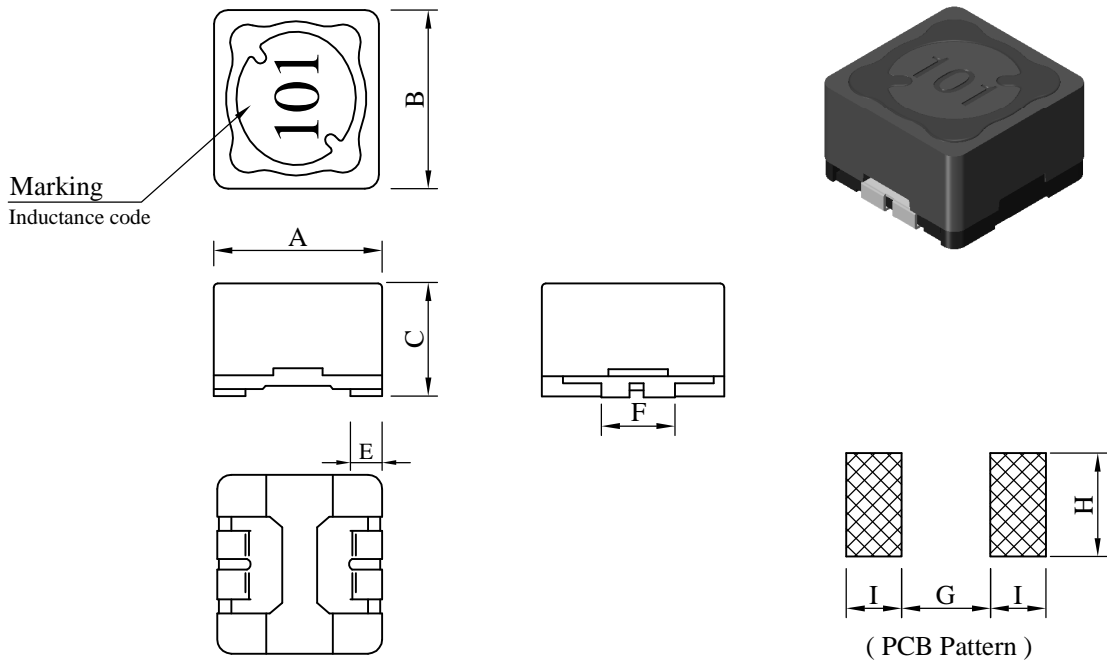

Unit : m/m

A	B	C	E	F	G	H	I
12.70 ±0.3	12.70 ±0.3	8.00 ±0.5	2.30 ±0.2	5.00 ±0.2	6.00 ref.	7.00 ref.	4.00 ref.

II . Description :

- a . Ferrite drum core construction.
- b . Magnetically shielded.
- c . Enamelled copper wire : H class
- d . Product weight : 4.25 g (ref.)
- e . Moisture sensitivity Level 1
- f . Products comply with RoHS' requirements
- g . Halogen free available

III . General specification :

- a . Storage temp. : -40°C ----+125°C
- b . Operating temp. : -40°C ----+125°C
(Temp. rise included)
- c . Resistance to solder heat : 245°C.10 secs.

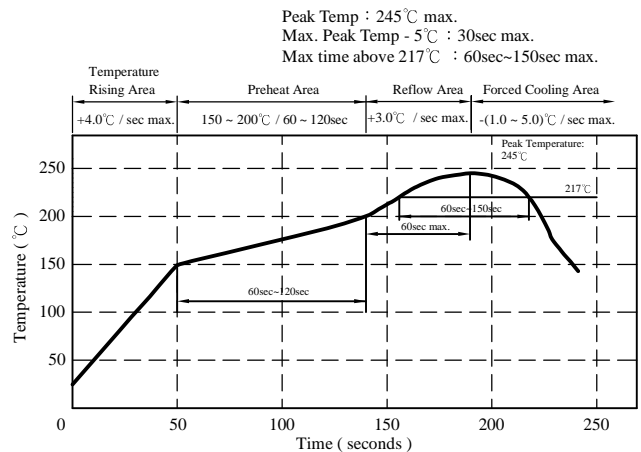

SPECIFICATION FOR APPROVAL

REF. :

PROD. NAME	Shielded SMD Power Inductor	ABC'S DWG NO.	SS1208□□□□T□-□□□		
		REV.	20160901-D	PAGE	2

IV . Electrical characteristics :

DWG No.	Inductance (uH)	Test Freq. (Hz)	SRF (MHz) min	RDC (mΩ) max	IDC (A) max
SS12082R5MT□-□□□	2.5±20%	1k	37.0	11.4	7.80
SS12084R5MT□-□□□	4.5±20%	1k	30.0	14.0	6.80
SS12086R5MT□-□□□	6.5±20%	1k	20.0	18.0	6.50
SS1208100MT□-□□□	10.0±20%	1k	15.0	21.0	5.40
SS1208120MT□-□□□	12.0±20%	1k	11.0	25.0	4.90
SS1208150MT□-□□□	15.0±20%	1k	11.0	36.0	4.50
SS1208180MT□-□□□	18.0±20%	1k	9.00	40.0	3.90
SS1208220MT□-□□□	22.0±20%	1k	7.00	43.0	3.60
SS1208270MT□-□□□	27.0±20%	1k	6.50	48.0	3.40
SS1208330YT□-□□□	33.0±15%	1k	6.50	62.0	3.00
SS1208390YT□-□□□	39.0±15%	1k	6.00	76.0	2.70
SS1208470YT□-□□□	47.0±15%	1k	5.00	85.0	2.50
SS1208560YT□-□□□	56.0±15%	1k	5.00	110.0	2.30
SS1208680YT□-□□□	68.0±15%	1k	5.00	135.0	2.10
SS1208820YT□-□□□	82.0±15%	1k	4.00	150.0	1.90
SS1208101YT□-□□□	100.0±15%	1k	4.00	170.0	1.70
SS1208121YT□-□□□	120.0±15%	1k	3.00	190.0	1.50
SS1208151YT□-□□□	150.0±15%	1k	3.00	240.0	1.40
SS1208181YT□-□□□	180.0±15%	1k	2.50	270.0	1.30
SS1208221KT□-□□□	220.0±10%	1k	2.50	380.0	1.10
SS1208271KT□-□□□	270.0±10%	1k	2.00	400.0	1.00
SS1208331KT□-□□□	330.0±10%	1k	1.80	650.0	0.90
SS1208391KT□-□□□	390.0±10%	1k	1.60	670.0	0.85
SS1208471KT□-□□□	470.0±10%	1k	1.40	850.0	0.80
SS1208561KT□-□□□	560.0±10%	1k	1.40	900.0	0.70
SS1208681KT□-□□□	680.0±10%	1k	1.20	1000.0	0.65
SS1208821KT□-□□□	820.0±10%	1k	1.20	1150.0	0.60
SS1208102KT□-□□□	1000.0±10%	1k	1.00	1650.0	0.55
SS1208122KT□-□□□	1200.0±10%	1k	0.80	2000.0	0.40
SS1208152KT□-□□□	1500.0±10%	1k	0.80	2350.0	0.36

1). □ : Packaging information : □ Code

2). "-□□□" : Reference code

3). Electrical specifications at 25°C

4). IDC base on Temp. rise 40°C max.

& ΔL/L0A=10% max.

AR-001C



SPECIFICATION FOR APPROVAL

REF. :

PROD. NAME	Shielded SMD Power Inductor	ABC'S DWG NO.	SS1208□□□□T□-□□□		
		REV.	20160901-D	PAGE	3

V . Curve :

SS1208150MT□

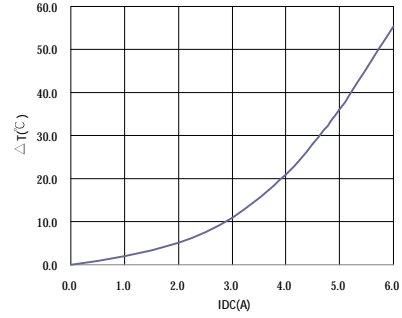
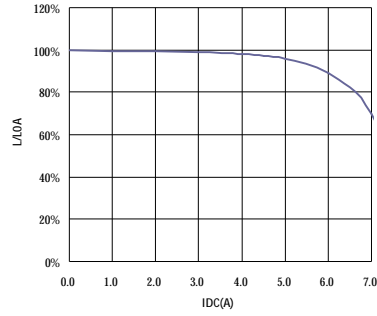

SS1208101YT□

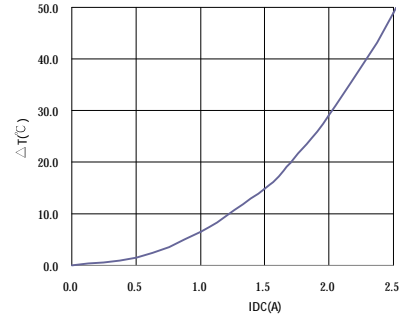
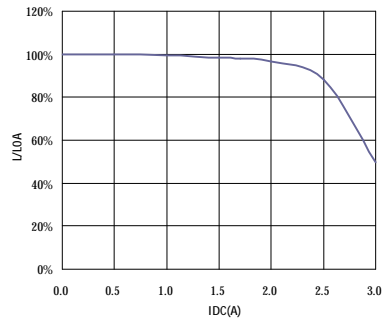

SS1208331KT□

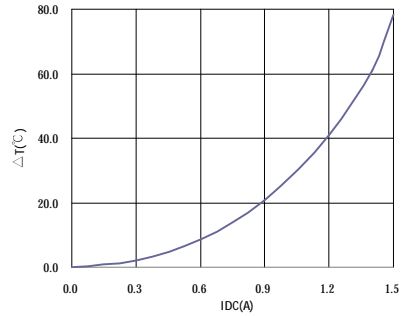
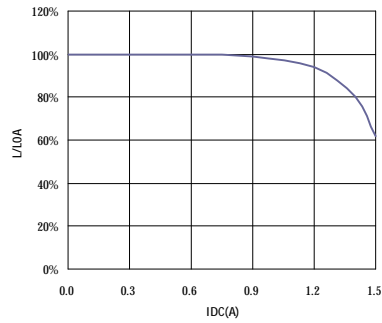

SS1208152KT□

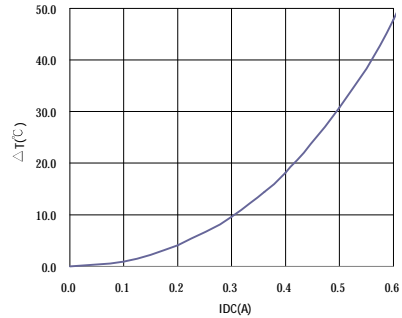
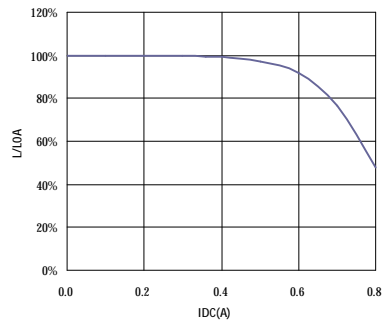

AR-001C

SPECIFICATION FOR APPROVAL

REF. :

PROD. NAME	Shielded SMD Power Inductor	ABC'S DWG NO.	SS1208□□□□T□-□□□		
		REV.	20160901-D	PAGE	4

VI . Packaging information :

(1) Configuration

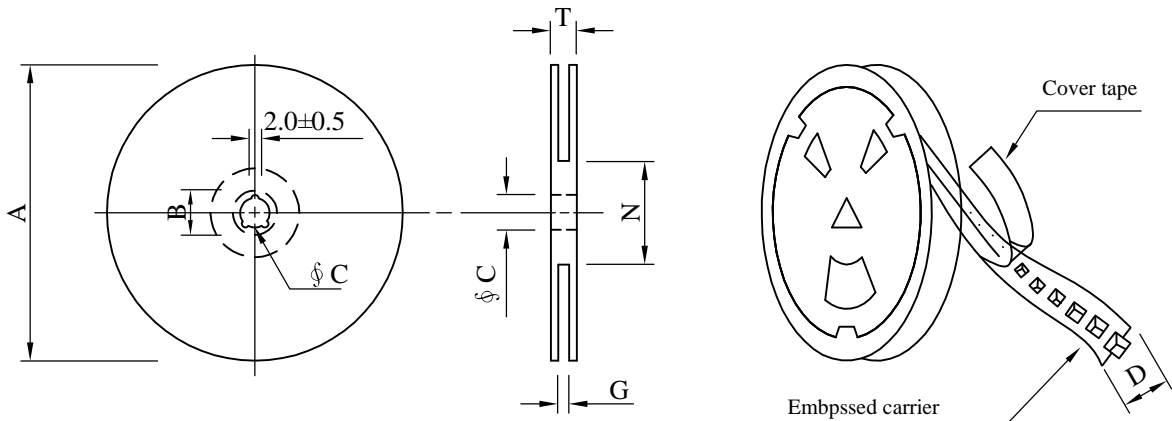

※Carrier tape width : D

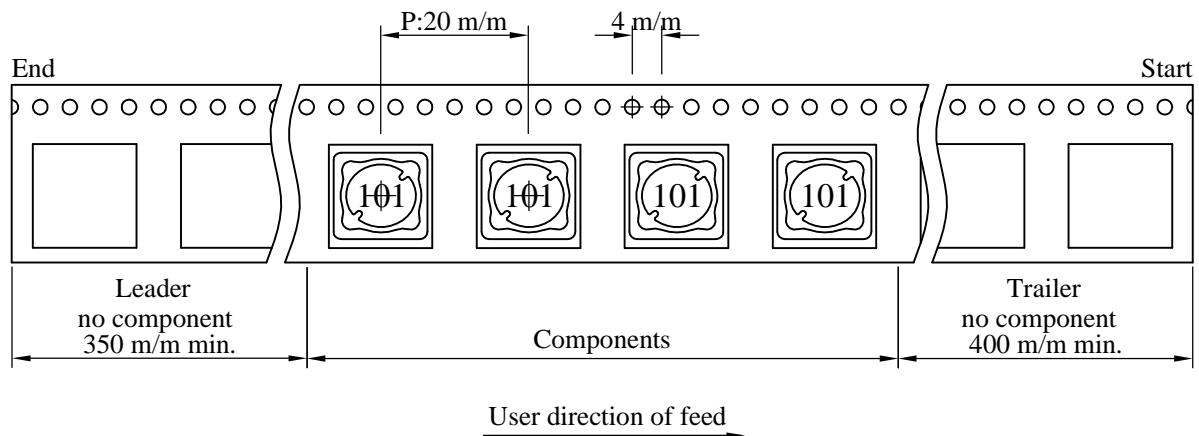

(2) Dimensions

Unit:m/m

Style	A	B	C	D	G	N	T
13 - 24	330	21±0.8	13±0.5	24	26 ⁺⁰	60 ⁻⁰	30.4

(3) Q'TY & G.W. Per package

Code	Inner : Reel			Outer : Carton		
	Q'TY (pcs)	G.W. (gw)	Style	Q'TY (pcs)	G.W. (Kg)	Size (cm)
B	400	2100	13 - 24	1,600	10.6	38 x 37 x 22

AR-001C

SPECIFICATION FOR APPROVAL

REF. :

PROD. NAME	Shielded SMD Power Inductor	ABC'S DWG NO.	SS1208□□□□T□-□□□		
		REV.	20160901-D	PAGE	6

VIII . Reliability test :

Item	Reference documents	Test Condition	Test Specification
1.High Temperature Exposure	MIL-STD-202 Method 108	1.Temperature: 125±2℃ 2.Time:96±2 hours.	1.No mechanical or electrical damage. 2.Inductance shall not change more than ±20%.
2.Temperature Cycling	JESD22-A 104	1.Temperature: -40℃ ~ +125℃ 2.Number of cycle:100 cycles 3.Dwell time:30 minutes	1.No mechanical or electrical damage. 2.Inductance shall not change more than ±20%.
3.Biased Humidity Test	MIL-STD-202 Method 103	1.Temperature : 85±2℃ 2.Humidity: 85% RH. 3.Time:96±2 Hours	1.No mechanical or electrical damage. 2.Inductance shall not change more than ±20%.
4.Operational Life	JESD22-A 108	1.Temperature: 125℃ (Temp. rise included) 2.Time:96±2 hours. 3.Rated current	1.No mechanical or electrical damage. 2.Inductance shall not change more than ±20%.
5.External Visual	JESD22-B 101 & MIL-STD-883 Method 2009	Inspect product constructions, marking and workmanship.	1.No pollution on the surface of products. 2.Clear marking. 3.No crack.
6.Physical Dimensions	JESD22-B 100	Verify physical dimensions to the applicable product detail specification.	Per product specification standard
7.Resistance to solvents	MIL-STD-202 Method 215	Immerse into solvent for 3±0.5 minutes & brush 10 times for 3 cycles.	1.No body change in apperance. 2.No marking blurred. 3.Inductance shall not change more than ±20%.
8.Vibration Test	MIL-STD-202 Method 204	1.Frequency and Amplitud : 10-2000-10 Hz, 1.5 mm. 2.Direction:X, Y, Z 3.Test duration:2 hours for each direction, 6 hours in total.	1.No mechanical or electrical damage. 2.Inductance shall not change more than ±20%.
9.Resistance To Soldering Heat Test	MIL-STD-202 Method 210 & J-STD020D.1	1.Highest temperature : 245±5℃. 2.Time (temp. ≥ 217℃) : 60~150 Seconds. 3.IR reflow times : 3 times.	1.No mechanical or electrical damage. 2.Inductance shall not change more than ±20%.
10.Saturation Current	JIS C 6436 & User SPEC.	1.Applied rated current for 5 seconds. 2.Saturation current	Inductance shall not drop more than 10% max.
11.Over load	JIS C 6436 & User SPEC.	1.Applied one and half rated current for a period of 5 minutes. 2.Rated current	No electrical or mechanical damage
12.Temperature Rise Current	JIS C 6436 & User SPEC.	1.Applied rated current for 10 minutes. 2.Temperature measure by digital surface thermometer. 3.Irms current	Surface temperature rise is less than 40℃ max.
13.Solderability Test	J-STD-002 & JESD22-B 102	1.Baking in pre-testing : 150±5℃ / 16Hours±30 min. 2.Peak temperature : 240±5℃ 3.Time (temp. ≥ 217℃) : 60~150 seconds. 4.IR reflow times : 1 time.	More than 95% soldering coverage min on terminations.
14.Electrical Characteriazation	MIL-STD-202 Method 304 & User SPEC.	1.Operating temperature : -40℃~125℃ 2.Room temperature : 25℃.	1.No mechanical or electrical damage. 2.Inductance shall not change more than ±20%.
15.Drop	CNS-C6354 & GB/T 2423.8	1.Products shall be mounted on SPEC. PCB and dropped down from a height of 1m 2.Drop total time : 6 times (Every side of sample drop 2 times)	1. Adhesion on PCB shall be enough. 2. Product appearance shall not break. 3. No electrical damage.
16.Terminal Strength Test	IEC 60068-2-21	1.Apply push force to samples mounted on PCB. 2.Force of 1.8 kg for 60±1 seconds.	After test, inductors shall be no mechanical damage.

AR-001C