

[Document Title](#)

**512K x16 bit Super Low Power and Low Voltage Full CMOS Static RAM**

[Revision History](#)

<b>Revision No.</b>	<b>History</b>	<b>Date</b>	<b>Remark</b>
0.0	-. Initial Draft	Apr. 7 2009	Preliminary
1.0	-. tDW updated to 40ns	Mar. 2 2010	

**Emerging Memory & Logic Solutions Inc.**

3F Korea Construction Financial Cooperative B/D, 301-1 Yeon-Dong, Jeju-Si, Jeju-Do, Rep.of Korea Zip Code : 690-717  
Tel : +82-64-740-1700 Fax : +82-64-740-1750 / Homepage : www.emlsi.com

---

The attached datasheets are provided by EMLSI reserve the right to change the specifications and products. EMLSI will answer to your questions about device. If you have any questions, please contact the EMLSI office.

**FEATURES**

- Process Technology : 0.15 $\mu$ m Full CMOS
- Organization : 512K x 16 bit
- Power Supply Voltage : 2.7V ~ 3.6V
- Low Data Retention Voltage : 1.5V(Min.)
- Three state output and TTL Compatible
- Package Type : 48-FPBGA

**GENERAL DESCRIPTION**

The EM680FV16B families are fabricated by EMLSI's advanced full CMOS process technology. The families support industrial temperature range and Chip Scale Package for user flexibility of system design. The families also supports low data retention voltage for battery back-up operation with low data retention current.

**PRODUCT FAMILY**

Product Family	Operating Temperature	Vcc Range	Speed	Power Dissipation		PKG Type
				Standby (I <sub>SB1</sub> , Typ.)	Operating (I <sub>CC1</sub> -Max.)	
EM680FV16B - xx <sup>1</sup> )LF	Industrial (-40 ~ 85°C)	2.7 ~ 3.6 V	45/55/70 ns	2 $\mu$ A <sup>2</sup> )	4 mA	48-FPBGA

1. "xx" represents speed.
2. Typical values are measured at Vcc=3.3V, T<sub>A</sub>=25°C and not 100% tested.

**FUNCTIONAL BLOCK DIAGRAM**

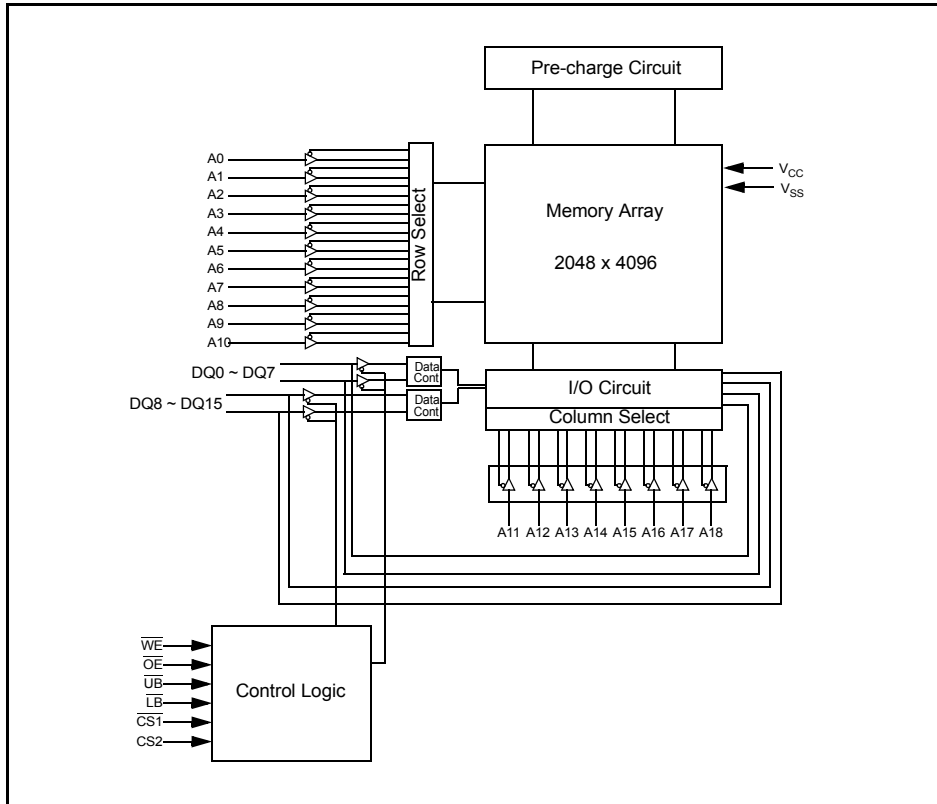

## PIN CONFIGURATIONS

FPBGA-48 : Top view(ball down)

	1	2	3	4	5	6
A	$\overline{\text{LB}}$	$\overline{\text{OE}}$	A0	A1	A2	CS2
B	DQ8	$\overline{\text{UB}}$	A3	A4	$\overline{\text{CS1}}$	DQ0
C	DQ9	DQ10	A5	A6	DQ1	DQ2
D	V <sub>SS</sub>	DQ11	A17	A7	DQ3	V <sub>CC</sub>
E	V <sub>CC</sub>	DQ12	NC	A16	DQ4	V <sub>SS</sub>
F	DQ14	DQ13	A14	A15	DQ5	DQ6
G	DQ15	NC	A12	A13	$\overline{\text{WE}}$	DQ7
H	A18	A8	A9	A10	A11	NC

## PIN DESCRIPTION

Name	Function	Name	Function
$\overline{\text{CS1}}$ , CS2	Chip Select inputs	V <sub>CC</sub>	Power Supply
$\overline{\text{OE}}$	Output Enable input	V <sub>SS</sub>	Ground
$\overline{\text{WE}}$	Write Enable input	$\overline{\text{UB}}$	Upper Byte (DQ8~DQ15)
A0~A18	Address inputs	$\overline{\text{LB}}$	Lower Byte (DQ0~DQ7)
DQ0~DQ15	Data inputs/outputs	NC	No Connection

**ABSOLUTE MAXIMUM RATINGS<sup>1)</sup>**

Parameter	Symbol	Ratings	Unit
Voltage on Any Pin Relative to V <sub>SS</sub>	V <sub>IN</sub> , V <sub>OUT</sub>	-0.2 to 4.0	V
Voltage on V <sub>CC</sub> supply relative to V <sub>SS</sub>	V <sub>CC</sub>	-0.2 to 4.0	V
Power Dissipation	P <sub>D</sub>	1.0	W
Operating Temperature	T <sub>A</sub>	-40 to 85	°C

1. Stresses greater than those listed under "Absolute Maximum Ratings" may cause permanent damage to the device. Functional operation should be restricted to recommended operating condition. Exposure to absolute maximum rating conditions for extended periods may affect reliability.

**FUNCTIONAL DESCRIPTION**

$\overline{CS1}$	$\overline{CS2}$	$\overline{OE}$	$\overline{WE}$	$\overline{LB}$	$\overline{UB}$	DQ0~7	DQ8~15	Mode	Power
H	X	X	X	X	X	High-Z	High-Z	Deselected	Stand by
X	L	X	X	X	X	High-Z	High-Z	Deselected	Stand by
X	X	X	X	H	H	High-Z	High-Z	Deselected	Stand by
L	H	H	H	L	X	High-Z	High-Z	Output Disabled	Active
L	H	H	H	X	L	High-Z	High-Z	Output Disabled	Active
L	H	L	H	L	H	Data Out	High-Z	Lower Byte Read	Active
L	H	L	H	H	L	High-Z	Data Out	Upper Byte Read	Active
L	H	L	H	L	L	Data Out	Data Out	Word Read	Active
L	H	X	L	L	H	Data In	High-Z	Lower Byte Write	Active
L	H	X	L	H	L	High-Z	Data In	Upper Byte Write	Active
L	H	X	L	L	L	Data In	Data In	Word Write	Active

**NOTE :** X means don't care. (Must be low or high state)

**RECOMMENDED DC OPERATING CONDITIONS** <sup>1)</sup>

Parameter	Symbol	Min	Typ	Max	Unit
Supply voltage	$V_{CC}$	2.7	3.3	3.6	V
Ground	$V_{SS}$	0	0	0	V
Input high voltage	$V_{IH}$	2.2	-	$V_{CC} + 0.2^{2)}$	V
Input low voltage	$V_{IL}$	$-0.2^{3)}$	-	0.6	V

1.  $T_A = -40$  to  $85^\circ\text{C}$ , otherwise specified
2. Overshoot:  $V_{CC} + 2.0$  V in case of pulse width  $\leq 20$ ns
3. Undershoot:  $-2.0$  V in case of pulse width  $\leq 20$ ns
4. Overshoot and undershoot are sampled, not 100% tested.

**CAPACITANCE** <sup>1)</sup> ( $f = 1\text{MHz}$ ,  $T_A = 25^\circ\text{C}$ )

Item	Symbol	Test Condition	Min	Max	Unit
Input capacitance	$C_{IN}$	$V_{IN} = 0\text{V}$	-	8	pF
Input/Output capacitance	$C_{IO}$	$V_{IO} = 0\text{V}$	-	10	pF

1. Capacitance is sampled, not 100% tested

**DC AND OPERATING CHARACTERISTICS**

Parameter	Symbol	Test Conditions	Min	Typ	Max	Unit	
Input leakage current	$I_{LI}$	$V_{IN} = V_{SS}$ to $V_{CC}$	-1	-	1	$\mu\text{A}$	
Output leakage current	$I_{LO}$	$\overline{CS1} = V_{IH}$ or $CS2 = V_{IL}$ or $\overline{OE} = V_{IH}$ or $\overline{WE} = V_{IL}$ or $\overline{LB} = \overline{UB} = V_{IH}$ $V_{IO} = V_{SS}$ to $V_{CC}$	-1	-	1	$\mu\text{A}$	
Operating power supply	$I_{CC}$	$I_{IO} = 0\text{mA}$ , $\overline{CS1} = V_{IL}$ , $CS2 = \overline{WE} = V_{IH}$ , $V_{IN} = V_{IH}$ or $V_{IL}$	-	-	2	mA	
Average operating current	$I_{CC1}$	Cycle time = $1\mu\text{s}$ , 100% duty, $I_{IO} = 0\text{mA}$ , $\overline{CS1} \leq 0.2\text{V}$ , $CS2 \geq V_{CC} - 0.2\text{V}$ , $\overline{LB} \leq 0.2\text{V}$ or/and $\overline{UB} \leq 0.2\text{V}$ , $V_{IN} \leq 0.2\text{V}$ or $V_{IN} \geq V_{CC} - 0.2\text{V}$	-	-	4	mA	
		Cycle time = Min, $I_{IO} = 0\text{mA}$ , 100% duty, $\overline{CS1} = V_{IL}$ , $CS2 = V_{IH}$ , $\overline{LB} = V_{IL}$ or/and $\overline{UB} = V_{IL}$ , $V_{IN} = V_{IL}$ or $V_{IH}$	45ns	-	-	45	mA
			55ns	-	-	35	
		70ns	-	-	25		
Output low voltage	$V_{OL}$	$I_{OL} = 2.1\text{mA}$	-	-	0.4	V	
Output high voltage	$V_{OH}$	$I_{OH} = -1.0\text{mA}$	2.4	-	-	V	
Standby Current (TTL)	$I_{SB}$	$\overline{CS1} = V_{IH}$ , $CS2 = V_{IL}$ , Other inputs = $V_{IH}$ or $V_{IL}$	-	-	0.5	mA	
Standby Current (CMOS)	$I_{SB1}$	$\overline{CS1} \geq V_{CC} - 0.2\text{V}$ , $CS2 \geq V_{CC} - 0.2\text{V}$ ( $\overline{CS1}$ controlled) or $0\text{V} \leq CS2 \leq 0.2\text{V}$ ( $CS2$ controlled), Other inputs = $0 \sim V_{CC}$ (Typ. condition : $V_{CC} = 3.3\text{V}$ @ $25^\circ\text{C}$ ) (Max. condition : $V_{CC} = 3.6\text{V}$ @ $85^\circ\text{C}$ )	LF	-	2 <sup>1)</sup>	15 $\mu\text{A}$	

1. Typical values are measured at  $V_{CC} = 3.3\text{V}$ ,  $T_A = 25^\circ\text{C}$  and not 100% tested.

### AC OPERATING CONDITIONS

**Test Conditions** (Test Load and Test Input/Output Reference)

Input Pulse Level : 0.4 to 2.4V

Input Rise and Fall Time : 5ns

Input and Output reference Voltage : 1.5V

Output Load (See right) :  $CL^{(1)} = 100\text{pF} + 1 \text{ TTL}(70\text{nsec})$

$CL^{(1)} = 30\text{pF} + 1 \text{ TTL}(45\text{ns}/55\text{ns})$

1. Including scope and Jig capacitance

2.  $R_1=3070\Omega$ ,  $R_2=3150\Omega$

3.  $V_{TM}=2.8\text{V}$

4.  $CL = 5\text{pF} + 1 \text{ TTL}$  (measurement with  $t_{LZ}$ ,  $t_{HZ}$ ,  $t_{OLZ}$ ,  $t_{OHZ}$ ,  $t_{WHZ}$ )

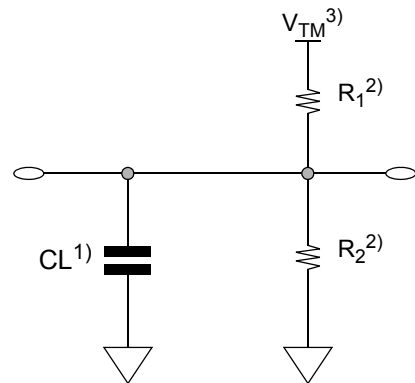

**READ CYCLE** ( $V_{CC}=2.7$  to  $3.6\text{V}$ ,  $Gnd = 0\text{V}$ ,  $T_A = -40^\circ\text{C}$  to  $+85^\circ\text{C}$ )

Parameter	Symbol	45ns		55ns		70ns		Unit
		Min	Max	Min	Max	Min	Max	
Read cycle time	$t_{RC}$	45	-	55	-	70	-	ns
Address access time	$t_{AA}$	-	45	-	55	-	70	ns
Chip select to output	$t_{CO1}, t_{CO2}$	-	45	-	55	-	70	ns
Output enable to valid output	$t_{OE}$	-	30	-	35	-	35	ns
$\overline{UB}$ , $\overline{LB}$ access time	$t_{BA}$		45		55		70	ns
Chip select to low-Z output	$t_{LZ1}, t_{LZ2}$	5	-	5	-	5	-	ns
$\overline{UB}$ , $\overline{LB}$ enable to low-Z output	$t_{BLZ}$	5	-	5	-	5	-	ns
Output enable to low-Z output	$t_{OLZ}$	5	-	5	-	5	-	ns
Chip disable to high-Z output	$t_{HZ1}, t_{HZ2}$	0	20	0	20	0	25	ns
$\overline{UB}$ , $\overline{LB}$ disable to how-Z output	$t_{BHZ}$	0	20	0	20	0	25	ns
Output disable to high-Z output	$t_{OHZ}$	0	20	0	20	0	25	ns
Output hold from address change	$t_{OH}$	10	-	10	-	10	-	ns

**WRITE CYCLE** ( $V_{CC}=2.7$  to  $3.6\text{V}$ ,  $Gnd = 0\text{V}$ ,  $T_A = -40^\circ\text{C}$  to  $+85^\circ\text{C}$ )

Parameter	Symbol	45ns		55ns		70ns		Unit
		Min	Max	Min	Max	Min	Max	
Write cycle time	$t_{WC}$	45	-	55	-	70	-	ns
Chip select to end of write	$t_{CW1}, t_{CW2}$	45	-	45	-	60	-	ns
Address setup time	$t_{As}$	0	-	0	-	0	-	ns
Address valid to end of write	$t_{AW}$	45	-	45	-	60	-	ns
$\overline{UB}$ , $\overline{LB}$ valid to end of write	$t_{BW}$	45	-	45	-	60	-	ns
Write pulse width	$t_{WP}$	45	-	45	-	55	-	ns
Write recovery time	$t_{WR}$	0	-	0	-	0	-	ns
Write to output high-Z	$t_{WHZ}$	0	20	0	20	0	25	ns
Data to write time overlap	$t_{DW}$	40		40		40		ns
Data hold from write time	$t_{DH}$	0	-	0	-	0	-	ns
End write to output low-Z	$t_{OW}$	5	-	5		5	-	ns

**TIMING DIAGRAMS**

**TIMING WAVEFORM OF READ CYCLE(1)** (Address Controlled,  $\overline{CS1}=\overline{OE}=V_{IL}$ ,  $CS2=\overline{WE}=V_{IH}$ ,  $\overline{UB}$  or/and  $\overline{LB}=V_{IL}$ )

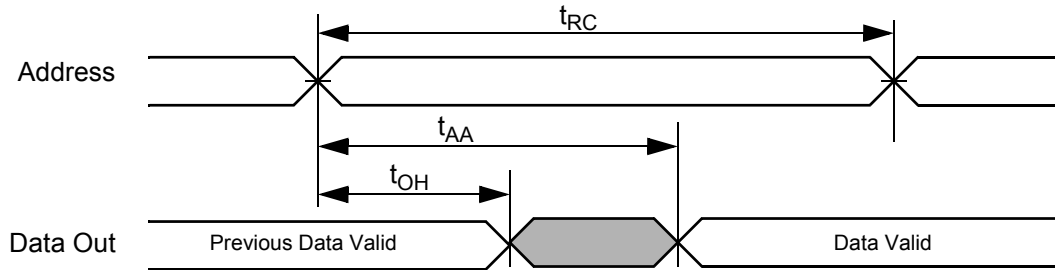

**TIMING WAVEFORM OF READ CYCLE(2)** ( $\overline{WE} = V_{IH}$ )

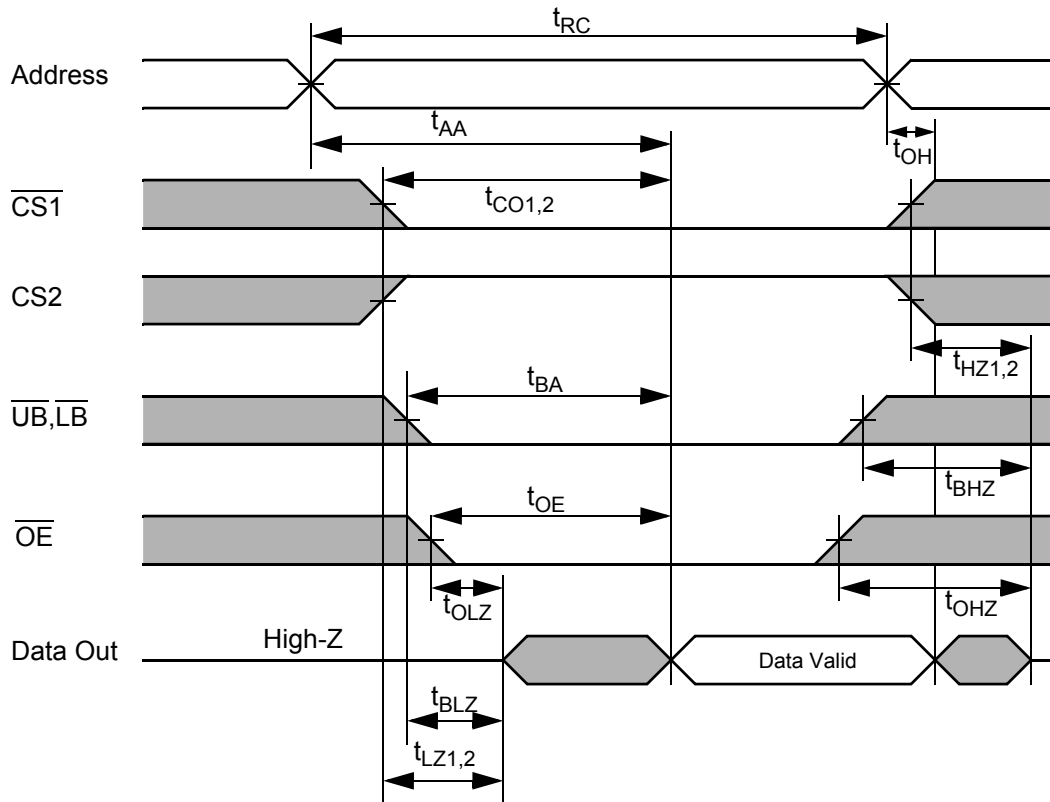

**NOTES (READ CYCLE)**

1.  $t_{HZ1,2}$  and  $t_{OHZ}$  are defined as the outputs achieve the open circuit conditions and are not referenced to output voltage levels.
2. At any given temperature and voltage condition,  $t_{HZ1,2}(\text{Max.})$  is less than  $t_{LZ1,2}(\text{Min.})$  both for a given device and from device to device interconnection.

**TIMING WAVEFORM OF WRITE CYCLE(1) ( $\overline{WE}$  Controlled)**

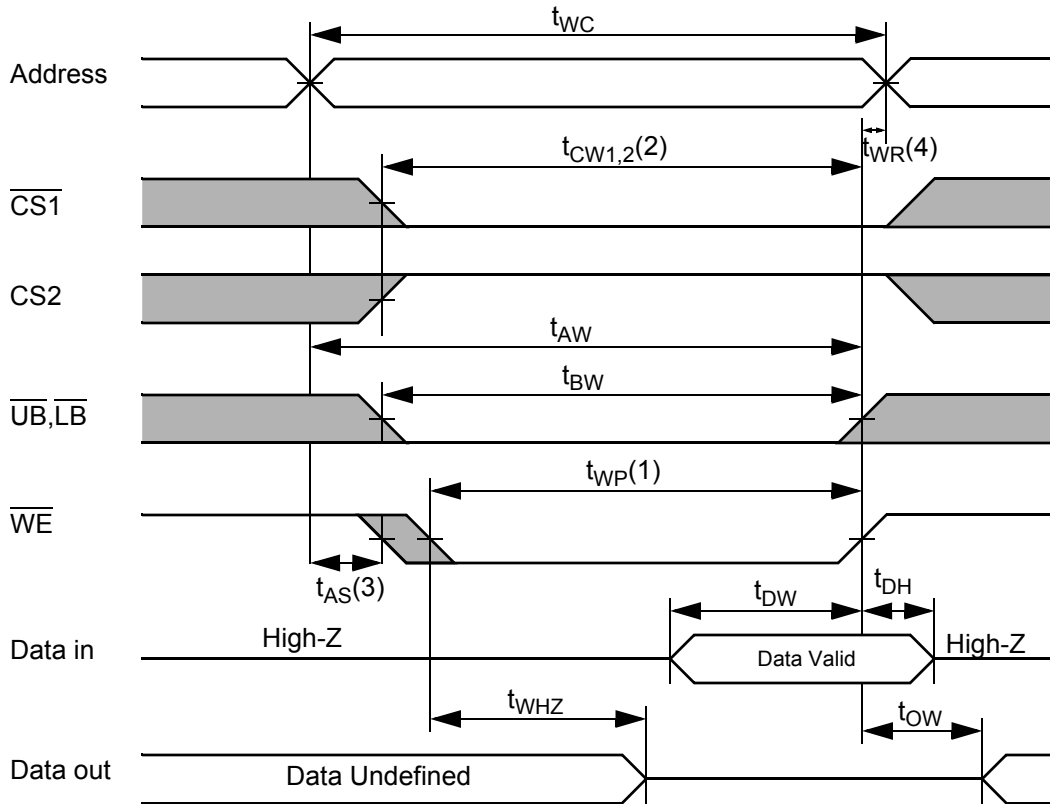

**TIMING WAVEFORM OF WRITE CYCLE(2) ( $\overline{CS1}$  Controlled)**

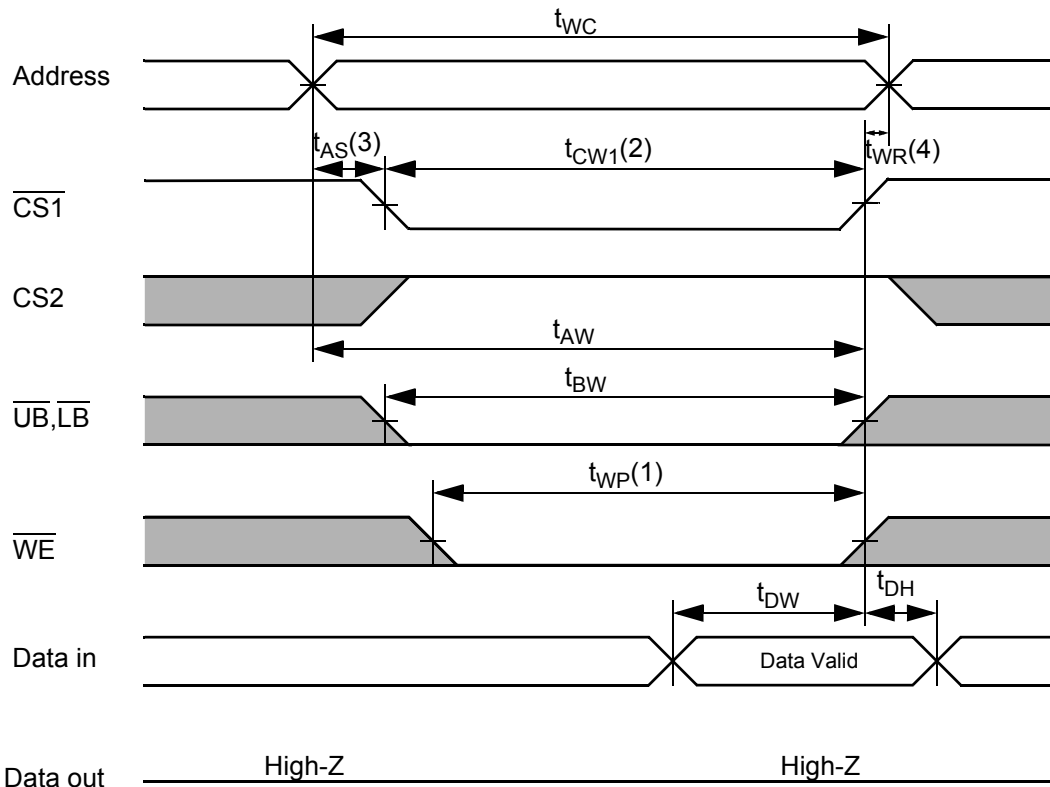



**TIMING WAVEFORM OF WRITE CYCLE(3) (CS2 Controlled)**

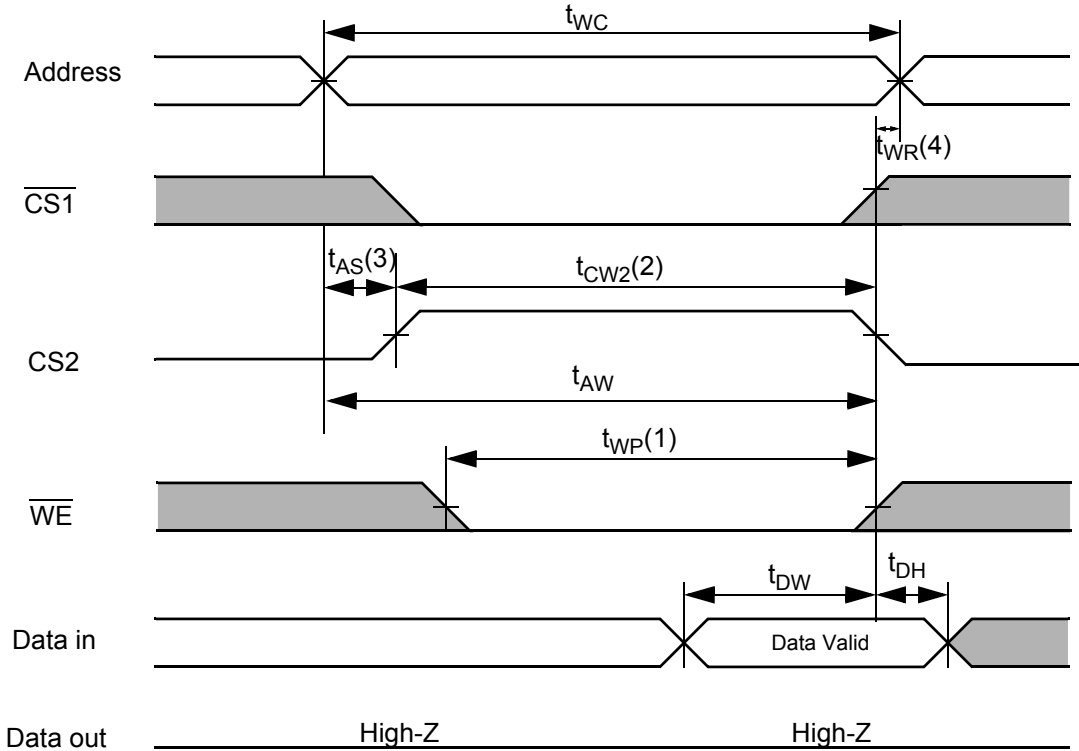

**TIMING WAVEFORM OF WRITE CYCLE(4) ( $\overline{UB}$ ,  $\overline{LB}$  Controlled)**

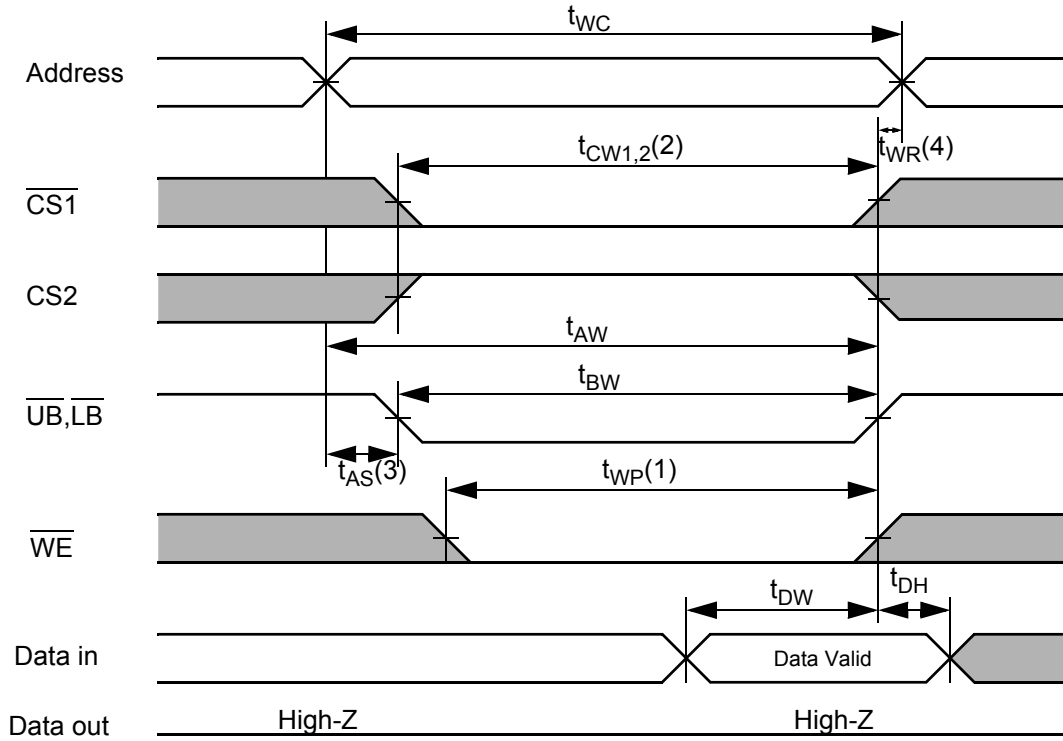

**NOTES (WRITE CYCLE)**

1. A write occurs during the overlap( $t_{WP}$ ) of low  $\overline{CS1}$ , a high  $CS2$  and low  $\overline{WE}$ . A write begins at the latest transition among  $\overline{CS1}$  goes low,  $CS2$  goes high and  $\overline{WE}$  goes low. A write ends at the earliest transition among  $\overline{CS1}$  goes high,  $CS2$  goes low and  $\overline{WE}$  goes high. The  $t_{WP}$  is measured from the beginning of write to the end of write.
2.  $t_{CW}$  is measured from the  $\overline{CS1}$  going low or  $CS2$  going high to end of write.
3.  $t_{AS}$  is measured from the address valid to the beginning of write.
4.  $t_{WR}$  is measured from the end of write to the address change.  $t_{WR}$  applied in case a write ends as  $\overline{CS1}$  or  $\overline{WE}$  going high or  $CS2$  going low.

**DATA RETENTION CHARACTERISTICS**

Parameter	Symbol	Test Condition	Min	Typ	Max	Unit
V <sub>CC</sub> for Data Retention	V <sub>DR</sub>	I <sub>SB1</sub> Test Condition (Chip Disabled) <sup>1</sup>	1.5	-	3.6	V
Data Retention Current	I <sub>DR</sub>	V <sub>CC</sub> =1.5V, I <sub>SB1</sub> Test Condition (Chip Disabled) <sup>1</sup>	-	-	4	μA
Chip Deselect to Data Retention Time	t <sub>SDR</sub>	See data retention wave form	0	-	-	ns
Operation Recovery Time	t <sub>RDR</sub>		t <sub>RC</sub>	-	-	

**NOTES**

1. See the I<sub>SB1</sub> measurement condition of datasheet page 5.

**DATA RETENTION WAVE FORM**

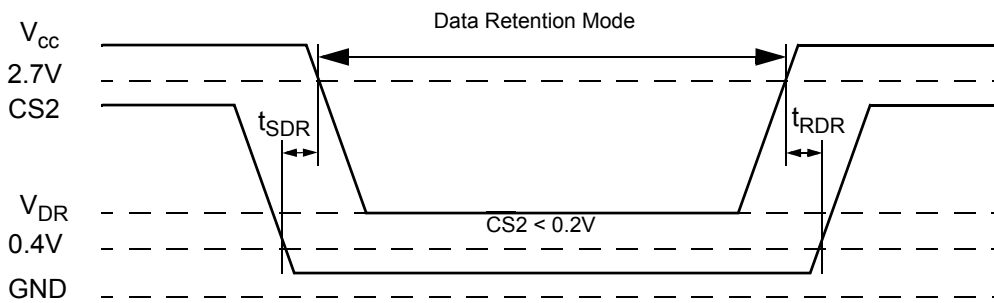
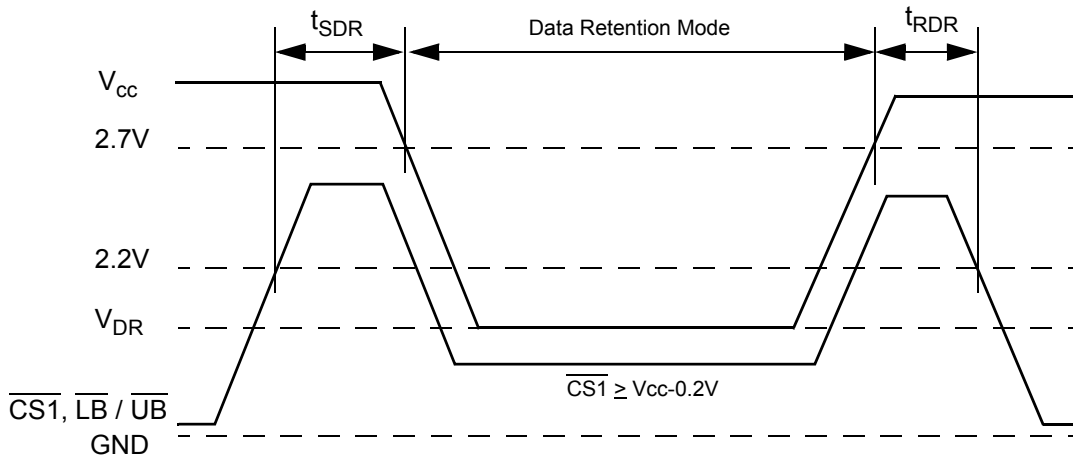

**PACKAGE DIMENSION**

48 Ball Fine Pitch BGA (0.75mm ball pitch)

Unit: millimeters

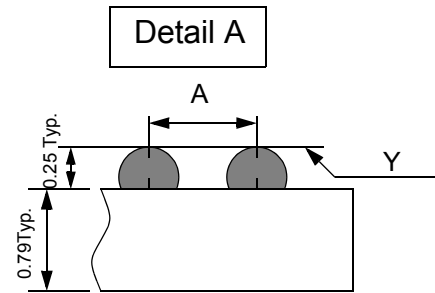
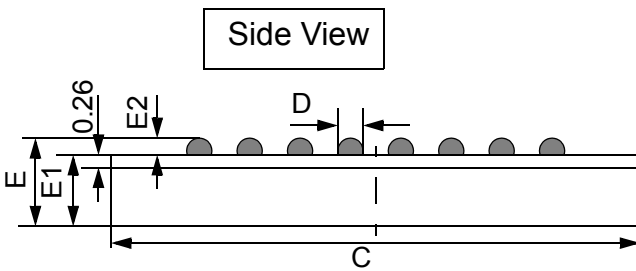
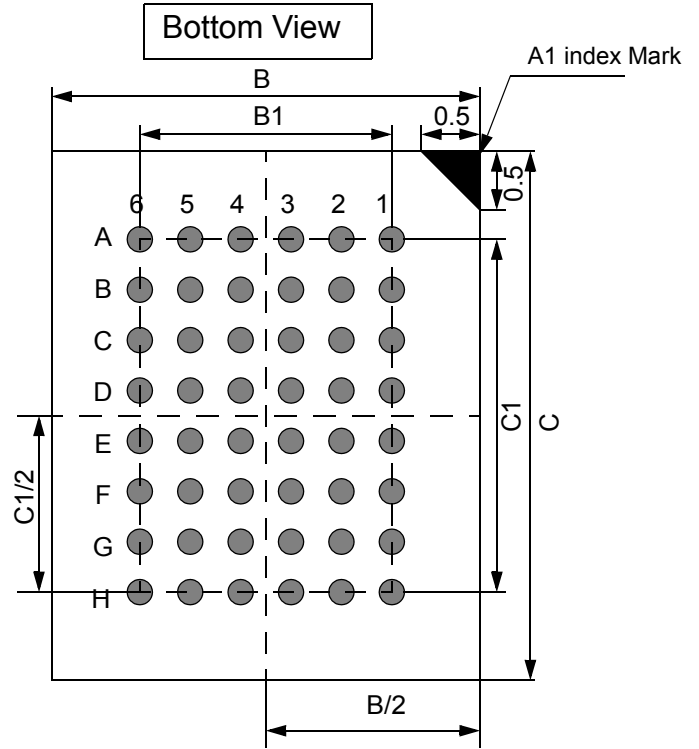
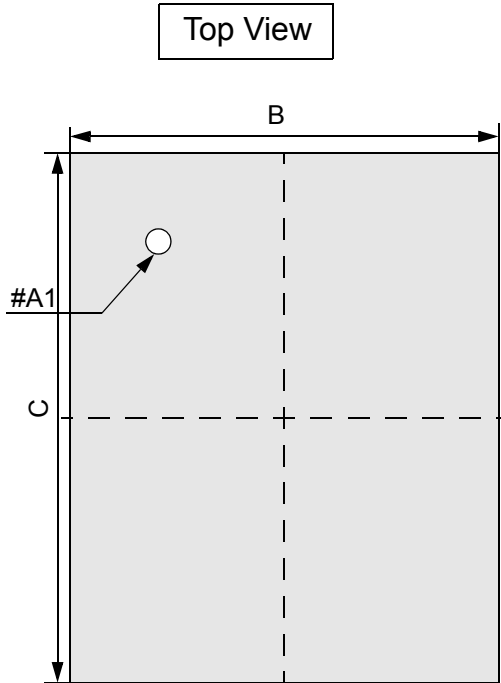

	Min	Typ	Max
A	-	0.75	-
B	7.95	8.00	8.05
B1	-	3.75	-
C	9.95	10.00	10.05
C1	-	5.25	-
D	0.30	0.35	0.40
E	-	-	1.00
E1	-	-	0.70
E2	0.20	0.25	0.30
Y	-	-	0.08

**NOTES.**

1. Bump counts : 48(8row x 6column)
2. Bump pitch : (x,y)=(0.75x0.75) (typ.)
3. All tolerance are +/-0.050 unless otherwise specified.
4. Typ : Typical
5. Y is coplanarity : 0.08(Max)

**MEMORY FUNCTION GUIDE**

EMXXXXXXXXXXXXX - XXXX

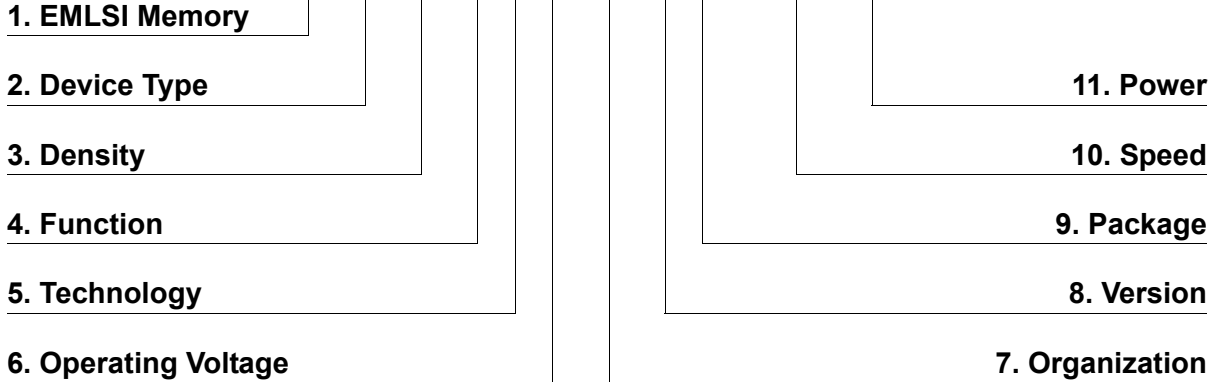

- 1. Memory Component
- 2. Device Type
  - 6 ----- Low Power SRAM
  - 7 ----- STRAM
  - C ----- CellularRAM
- 3. Density
  - 1 ----- 1M
  - 2 ----- 2M
  - 4 ----- 4M
  - 8 ----- 8M
  - 16 ----- 16M
  - 32 ----- 32M
  - 64 ----- 64M
  - 28 ----- 128M
- 4. Option
  - 0 ----- Dual CS
  - 1 ----- Single CS
- 5. Technology
  - F ----- Full CMOS
- 6. Operating Voltage
  - T ----- 5.0V
  - V ----- 3.3V
  - U ----- 3.0V
  - S ----- 2.5V
  - R ----- 2.0V
  - P ----- 1.8V
- 7. Organization
  - 8 ----- X8 bit
  - 16 ----- X16 bit
  - 32 ----- X32 bit

- 8. Version
  - Blank----- Mother die
  - A ----- 2 nd generation
  - B ----- 3 rd generation
  - C ----- 4 th generation
  - D ----- 5 th generation
  - E ----- 6 th generation
  - F ----- 7 th generation
  - G ----- 8 th generation
- 9. Package
  - Blank----- KGD, FBGA
  - S ----- 32 sTSOP1
  - T ----- 32 TSOP1
  - U ----- 44 TSOP2
  - V ----- 32 SOP
- 10. Speed
  - 45 ----- 45ns
  - 55 ----- 55ns
  - 60 ----- 60ns
  - 70 ----- 70ns
  - 85 ----- 85ns
  - 90 ----- 90ns
  - 10 ----- 100ns
  - 12 ----- 120ns
- 11. Power
  - LL ----- Low Low Power
  - LF ----- Low Low Power(Pb-free & Green)
  - L ----- Low Power
  - S ----- Standard Power