

SPECIFICATION FOR APPROVAL

- ※This is a RoHS and REACH compliant product whose related documents are available on request.
- ※Graphic is only for dimensionally application.

1. PART NUMBERING IDENTIFICATION

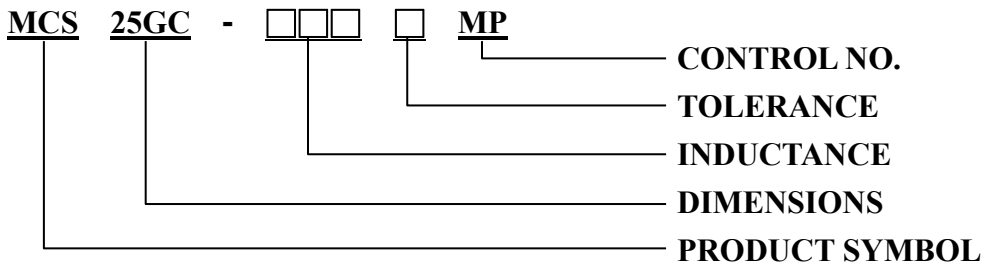

2. MECHANICAL DIMENSION

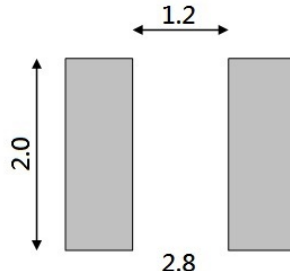
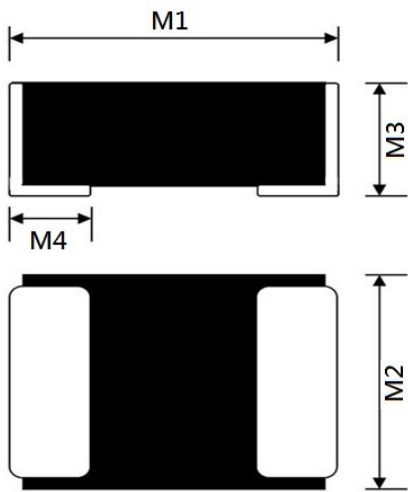

UNIT: mm

	DIM.	TOL.
M1	2.5	±0.2
M2	2.0	±0.2
M3	1.0	MAX.
M4	0.6	±0.3

3. ELECTRICAL SPECIFICATION

Part number	Inductance (uH) ±20%	DC Resistance (mΩ) Typical	DC Resistance (mΩ) MAX.	Irms (A) Typical	Irms (A) MAX.	I sat (A) Typical	I sat (A) MAX.
MCS25GC-R22MMP	0.22	9	12.5	5.9	5.3	7.9	7.2
MCS25GC-R33MMP	0.33	21	26	4.4	4.0	6.6	6.0
MCS25GC-R47MMP	0.47	27	32	3.9	3.51	5.0	4.5
MCS25GC-R68MMP	0.68	37	44	3.4	3.06	4.3	3.87
MCS25GC-1R0MMP	1.0	45	54	3.0	2.70	3.5	3.15
MCS25GC-1R5MMP	1.5	76	91	2.5	2.25	2.6	2.34
MCS25GC-2R2MMP	2.2	99	119	2.3	2.07	2.4	2.16
MCS25GC-4R7MMP	4.7	220	262	1.36	1.22	1.8	1.62

NOTE:

1. Test Freq.: 1MHz, 1V
2. All test referenced to 26°C ambient.
3. Operating Temperature range: -40°C to +125°C
4. Storage Temperature range: -50°C to +125°C
5. Isat means that DC current will cause a 30% inductance reduction from initial value.
6. Irms means that DC current will cause coil temp. rising to 40°C whichever is smaller.

SPECIFICATION FOR APPROVAL

4. ELECTRICAL CURVE

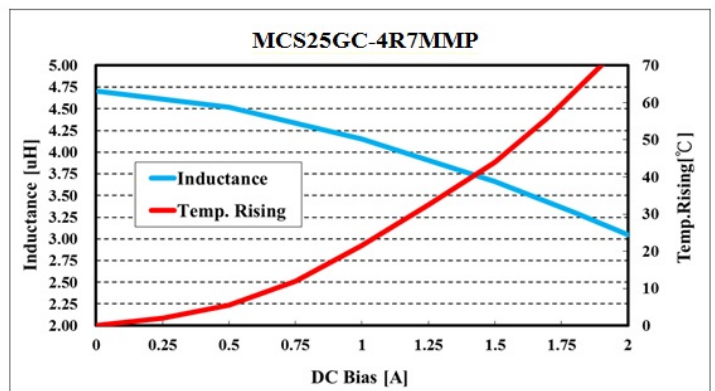
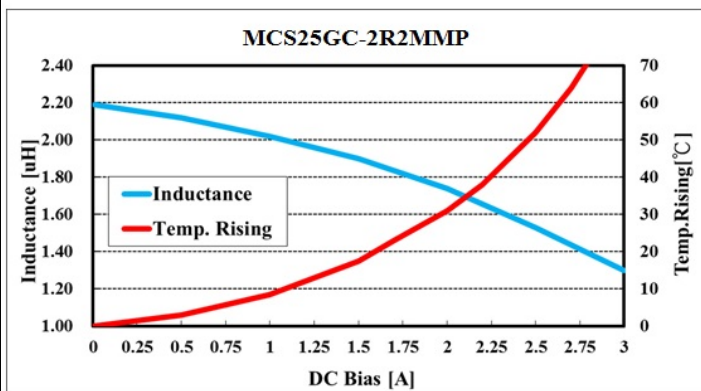
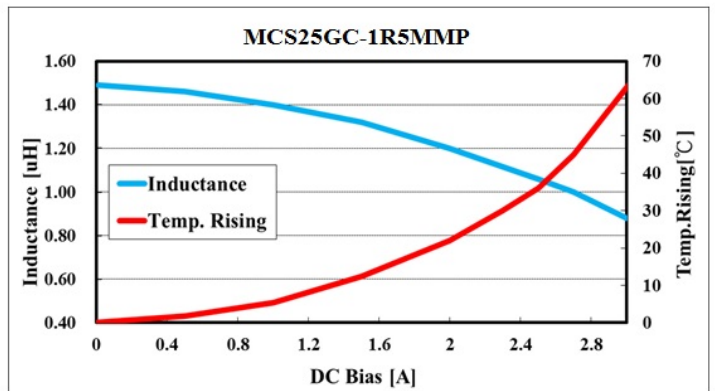
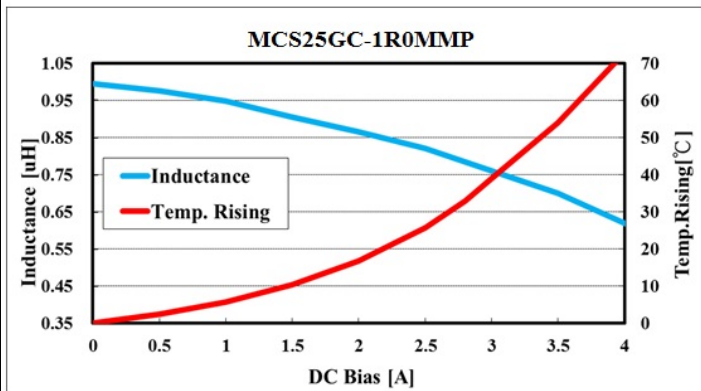
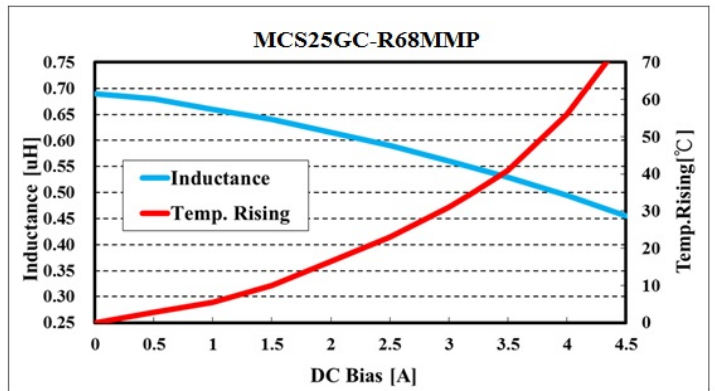
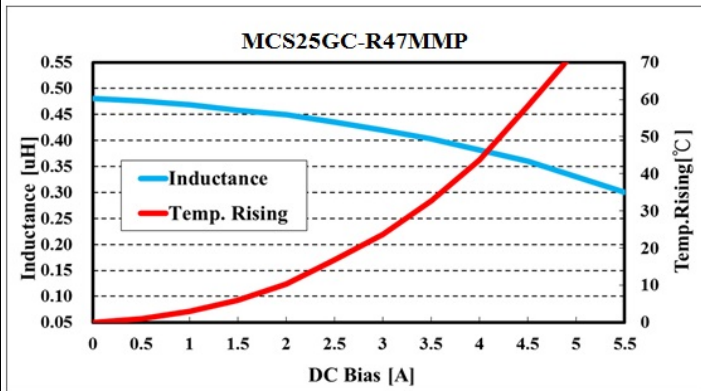
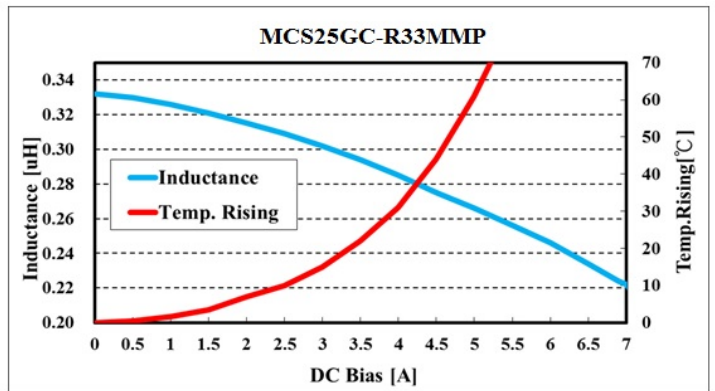
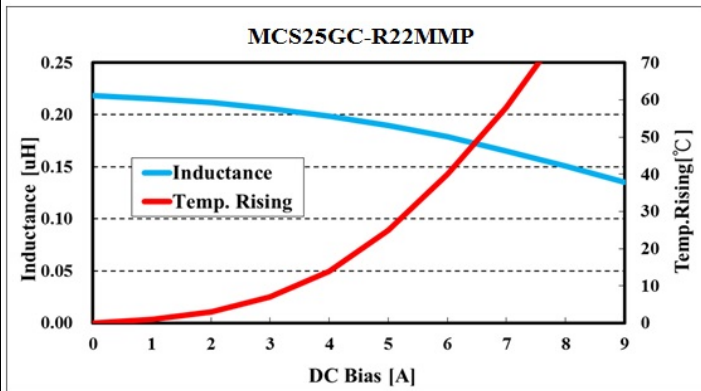

SPECIFICATION FOR APPROVAL

5. PACKING

5.1 Carrier tape dimensions

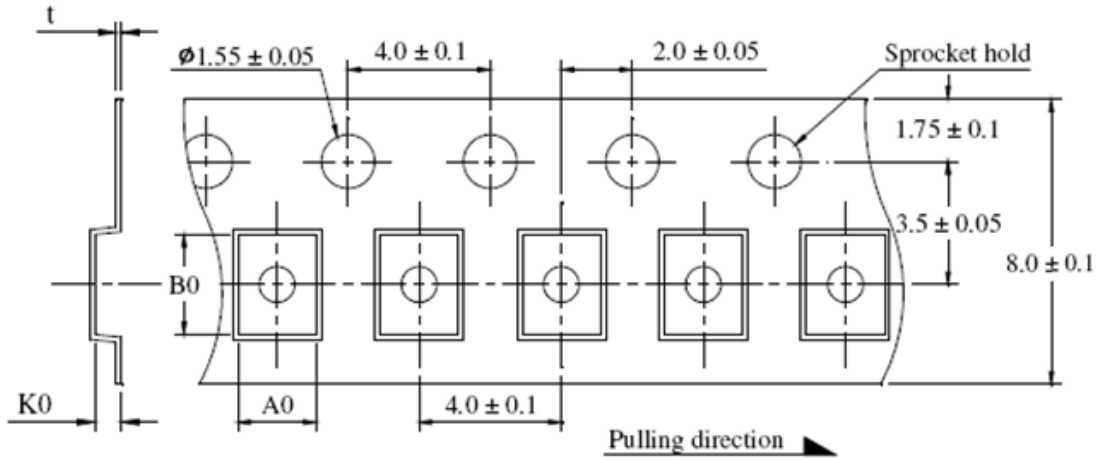

UNIT : mm

	A0	B0	K0	t
DIM.	2.25±0.05	2.80±0.1	1.35±0.1	0.22±0.05

5.2 Taping reel dimensions

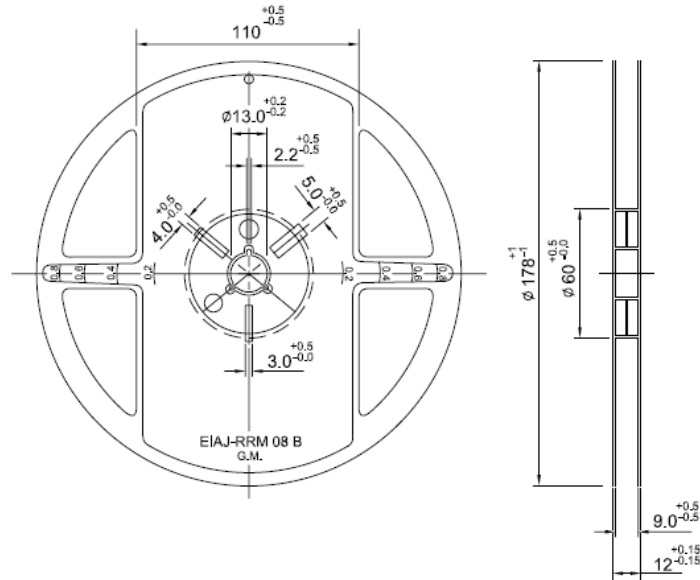

Qty.(pcs)	3,000
BOX	5 reels / inner box