

VECO VANSONIC ENTERPRISE CO.,LTD.

8F.,No.7,Lane 16, Sec.2, Szechwan Road, Panchiao, Taipei Hsien, TAIWAN.

TEL: +886-2-29626335

FAX: +886-2-29625220

E-MAIL:vansonic@ms4.hinet.net

1.	MODEL:	35KN08-1
2.	Dimension	Outer Diameter 35 X16 mm. Baffle Opening 32X15 mm.
		Height Refer to Drawing . Weight 2.8 Grams.
3.	Magnet	Materials Rare Earth . Size ∅ 7.9X1.3 mm.
4.	Resistance	8 ± 15 %
5.	Power Rating	Normal 1.0 W. Maximum 1.5 W.
6.	Lowest Resonant Frequency	700 ± 20 % Hz.
7.	Output Sound Pressure Lever (S.P.L.)	80 ± 3 db / 1.0 Watt . 0.5 Meter.
		Average at 800, 1000, 1200, 1500 Hz.
8.	Frequency Range	300 ~ 20000 Hz. Average S P L - 10 db.
9.	Distortion	5 % Maximum At 1000 Hz. 1.0 W.
10.	Abnormal Sound Test	Must Be Normal Tested By 2.9 Volts. Sine Wave.
11.	Load Test	White Noise With Weighted Filter 2.9 Volts.(RMS) 24 Hrs.
12.	Polarity	Diaphragm shall move Forward when Apply a Positive DC.
		Current to the "+" or "Marked" Terminal.

MOUNTING NOTICE

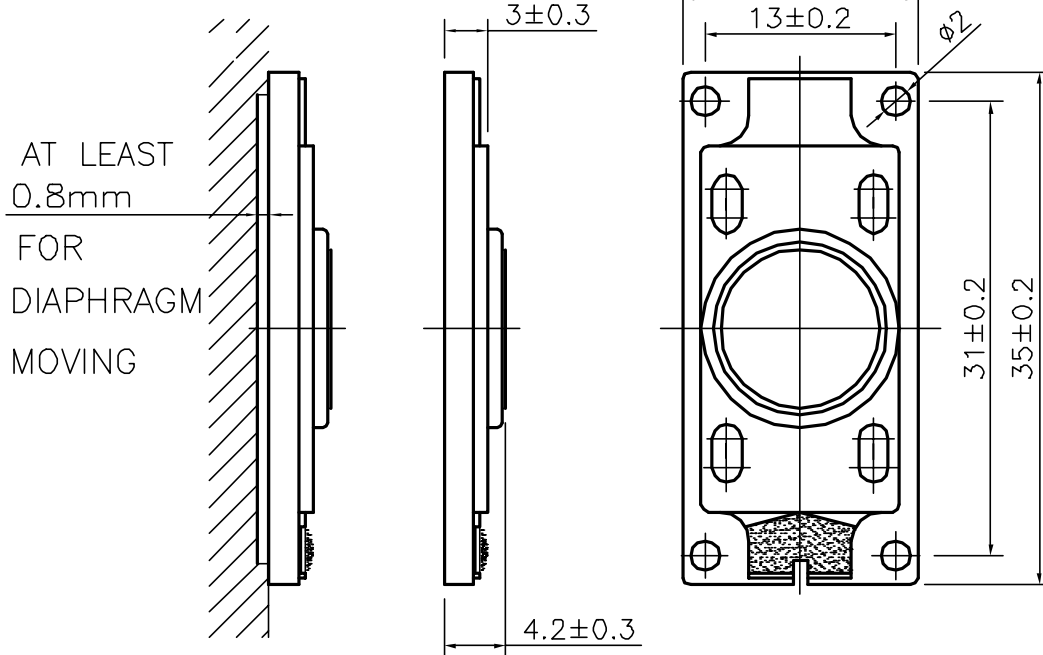

Unit : mm

Housing Material : ABS

35KN08-1 VOL:2.828V(1W) DIS:0.5M VANSONIC
X:1.0000kHz *Y:84.34dB ZA:1.0000 SSR Fund.

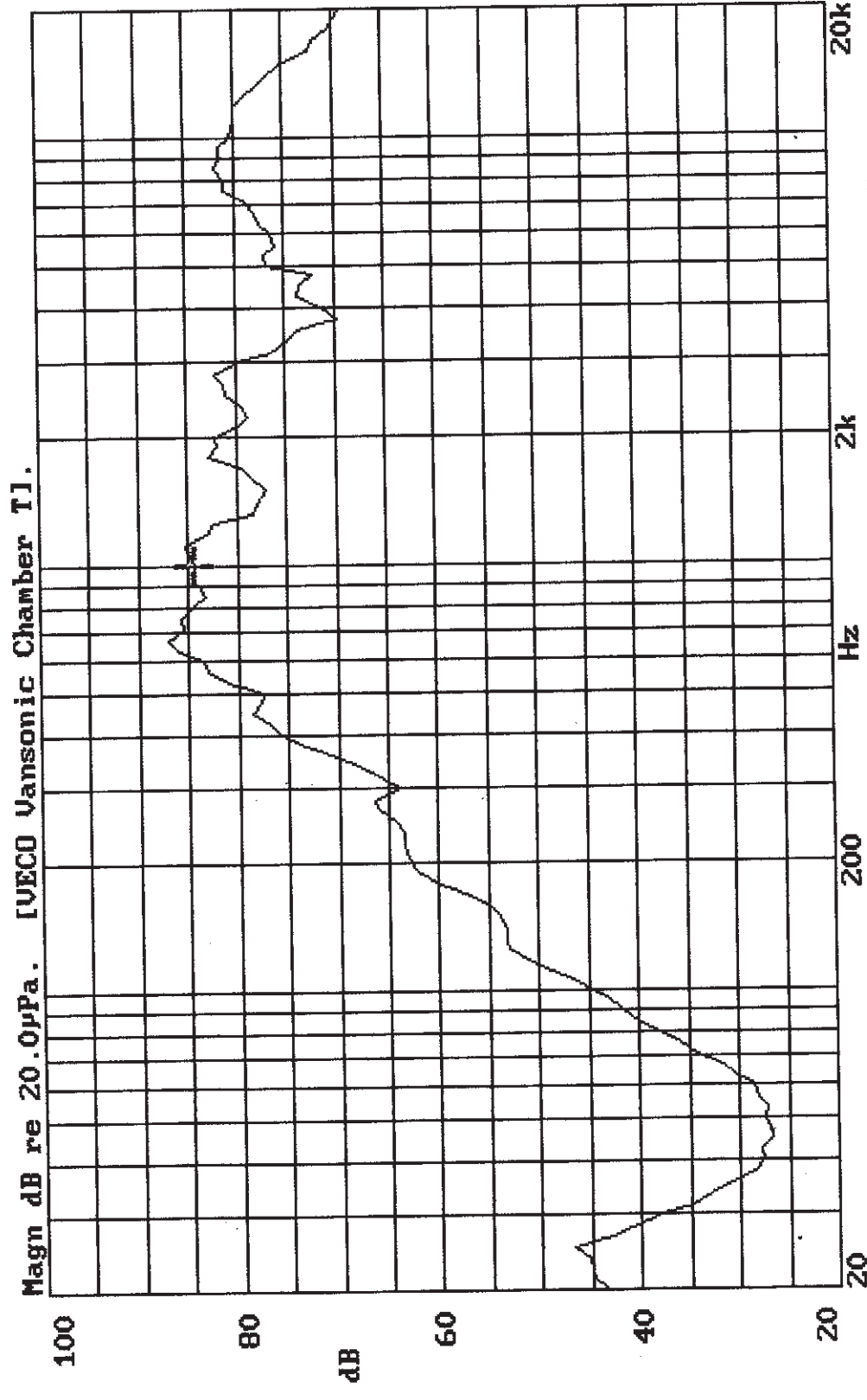

06-JUN-2002 17:52:11

Mode: SSR