

# VECO VANSONIC ENTERPRISE CO.,LTD.

8F., No7, Lane16, Sec2, Szechwan Road, Panchiao, Taipei Hsien, TAIWAN.  
 E-mail: [Vansonic@ms4.hinet.net](mailto:Vansonic@ms4.hinet.net) Homepage: <http://www.veco.com.tw>  
 TEL: +886-2-962 6335 FAX: +886-2-962 5220

1.	<b>MODEL:</b>	<b>3010KMG04 DYNAMIC SPEAKER</b>
2.	Dimension	Outer Diameter <b>30*10</b> mm.
		Height <b>Refer to Fig 1</b> mm. Weight <b>1.6</b> Grams.
3.	Magnet	Materials <b>NdFeB</b>
4.	Impedance	<b>4 Ω ± 15 %</b> At <b>1500</b> Hz.
5.	Power Rating	Normal <b>1.0</b> W. Maximum <b>1.5</b> W.
6.	Lowest Resonant Frequency	<b>900 ± 20% Hz</b> at 1.0V measured by SUNLILAB® 7117C
7.	Output Sound Pressure (S.P.L.)	<b>81 ± 3 db / 1.0Watt · 0.5Meter</b> , Measured by B&K Type 2012
		At 800, 1000, 1200, 1500 HZ Average
8.	Frequency Range	<b>450 ~ 20,000</b> Hz. Average SPL -10db Refer to Fig. 2
9.	Distortion	<b>5% Maximum</b> at 1000 Hz 1 W.
10.	Abnormal Sound Test	Must be Normal Tested By <b>2.0Volts</b> . Sine Wave.
11.	Load Test	Pink noise with HPF(High Pass Filter 235HZ-3db-11db/Oct) <b>2.0Volts(RMS.)24hrs</b> .
12.	Storage Temperature	<b>- 25°C ~ + 65°C</b>
13.	Operating Temperature	<b>- 20°C ~ + 60°C</b>

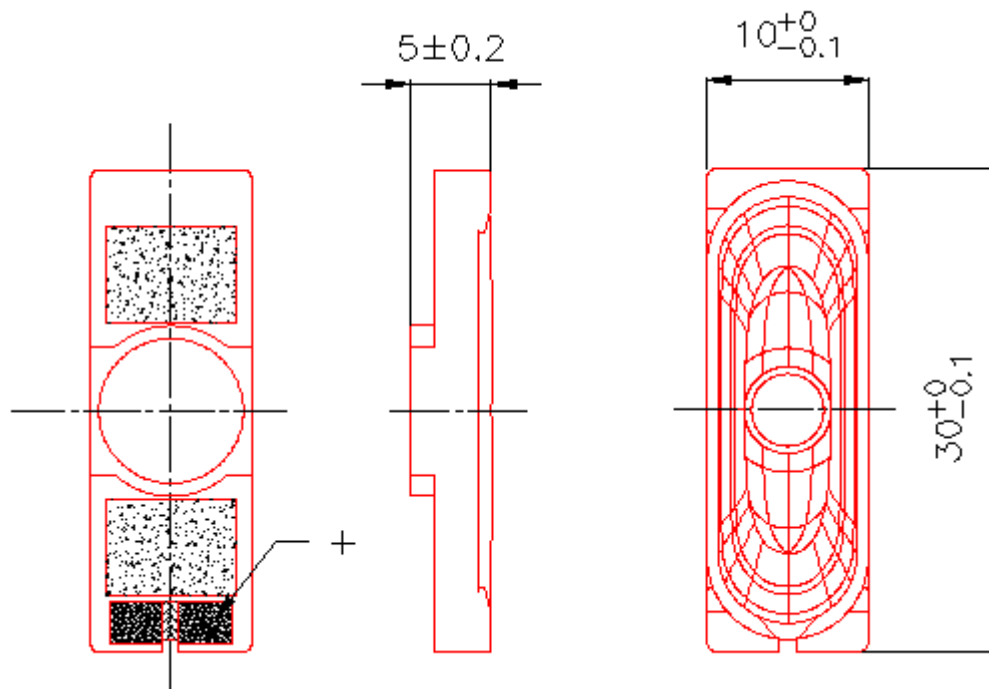

PRELIMINARY

Fig.1

# 14.Frequency Response Curve.

14.1 Speaker

Sound Pressure Level(SPL) :  $81 \pm 3$  dB 1.0W/0.5M at (800,1k,1.2k,1.5k) AV

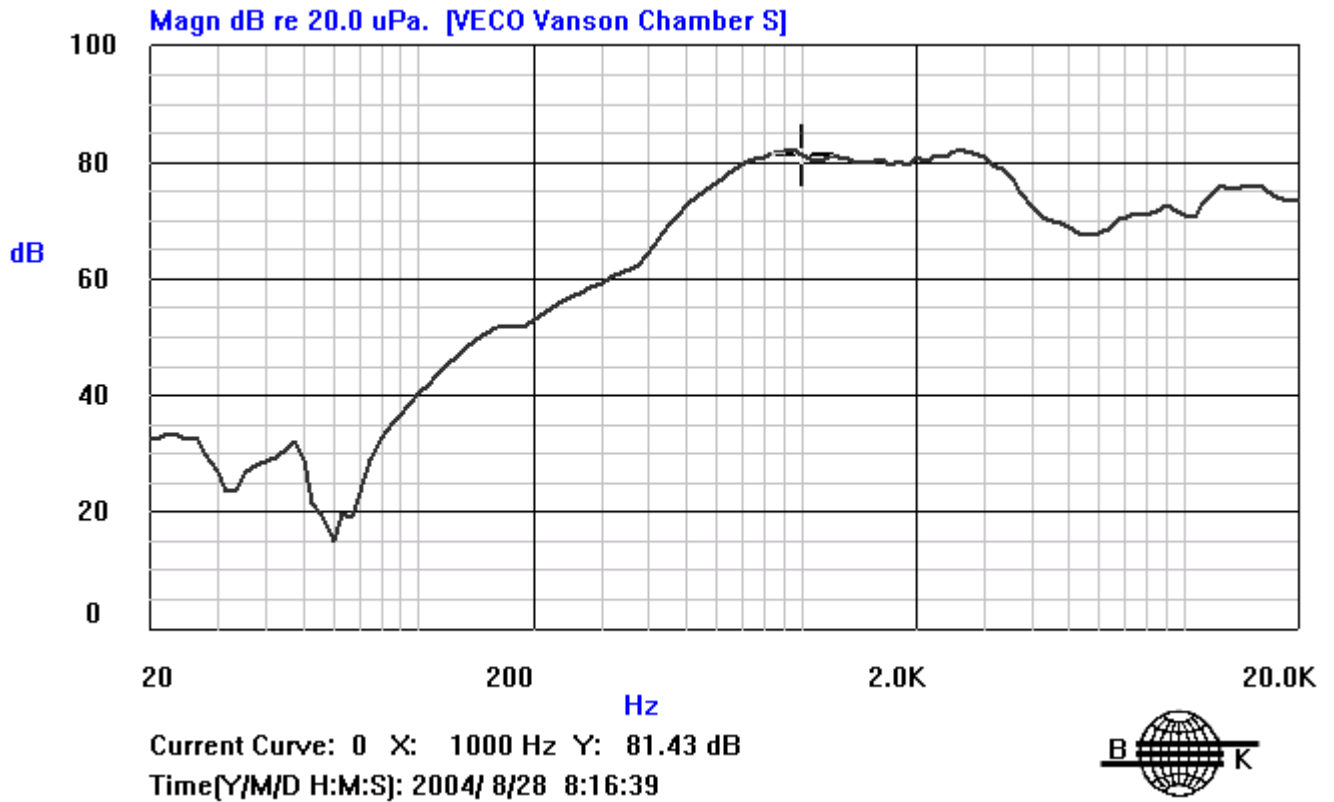

INPUT: 1.0W  
MIC DIST: 0.5M  
BAFFLE: IEC6028-5

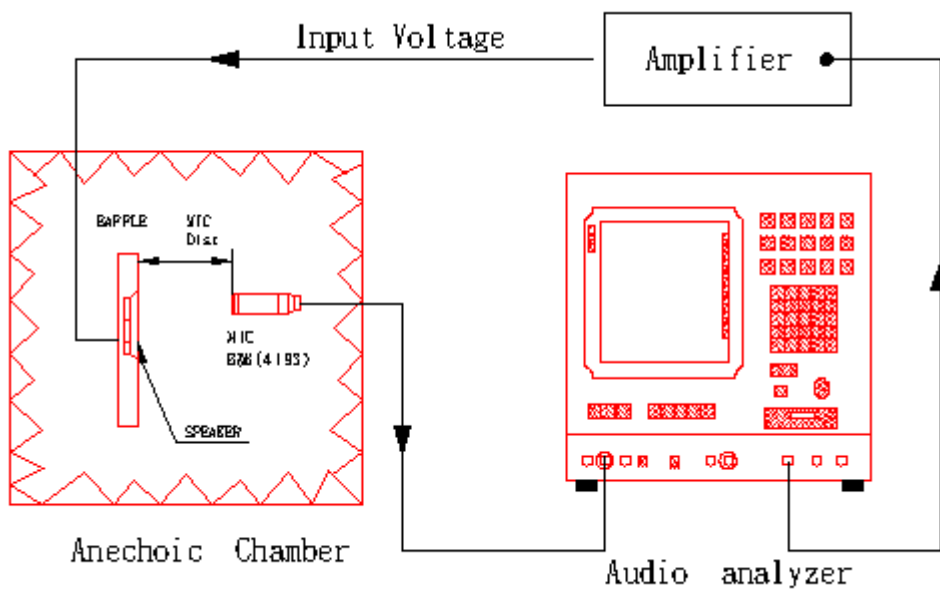

**PRELIMINARY**

Fig.2

## 15.Environment Test

### 15.1 Environment test – High temperature.

After exposure the speaker in the  $+ 65 \pm 3$  °C chamber for 24 hours, then leave the speaker at room temperature for 1 hour, the SPL should not deviate by  $\pm 3$  db, compare with pre-test measurement.

### 15.2 Environment test - Low temperature.

After exposure the speaker in the  $- 25 \pm 3$  °C chamber for 24 hours, then leave the speaker at room temperature for 1 hour, the SPL should not deviate by  $\pm 3$  db, compare with pre-test measurement.

### 15.3 Environment test-Temperature cycle.

After exposure the speaker in the chamber, temperature cycle setting as below shows, SPL should not Deviate by  $\pm 4$ db,compare with pre-test measurement.

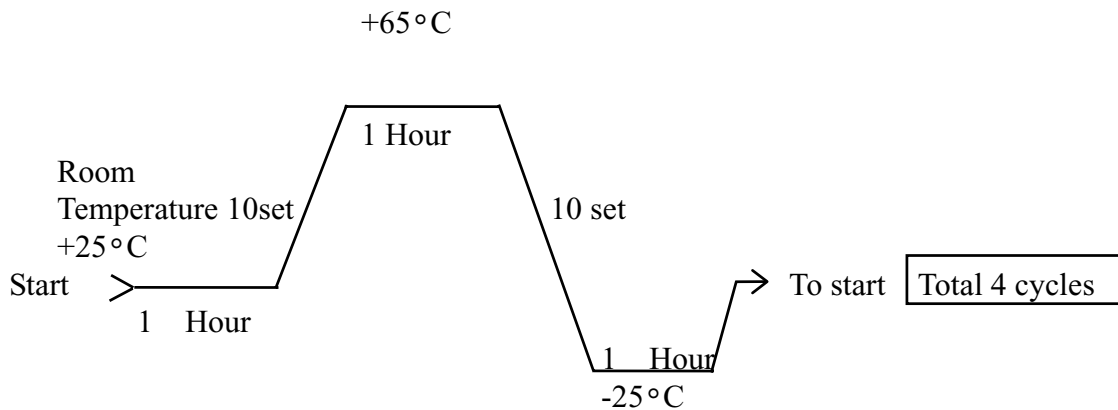

### 15.4 Environment test – Humidity.

After exposure the speaker in the  $+ 40 \pm 3$  °C, relative humidity 90% ~95% chamber for 24 hours, then leave the speaker at room temperature for 6 hours, the SPL should not deviate by  $\pm 3$ db, compare with pre-test measurement.

**PRELIMINARY**