

AUTOMOTIVE APPLICATIONS

ADVANCED CIRCUIT PROTECTION DEVICES FOR OVERVOLTAGE TRANSIENT EVENTS



PROTEK DEVICES[®]

ONLY ONE NAME MEANS PROTEK'TION™

The automobile has come a long way since the 1970s. Modern vehicles now utilize dozens of interconnected modules to manage everything from adaptive cruise control to fuel injection to high performance sensors for collision control. These advanced electronic control systems, including mandatory safety systems, require circuit protection.

TRANSIENTS IN AUTOMOTIVE SYSTEMS				
TIME DURATION	CAUSE	VOLTAGE AMPLITUDE	ENERGY LEVEL	FREQUENCY OF OCCURRENCE
400ms	Load Dump (Disconnection of battery while at high charging)	< 202V	> 10J	Infrequent
Steady State	Failed Voltage Regulator	18V	-	Infrequent
< 320µs	Inductive Load Switching	80V to 300V	< 1J	Often
200ms	Alternator Field Decay	-100V to -40V	< 1J	Each Turn-Off
90ms	Ignition Pulse, Battery Disconnected	< 75V	< 0.5J	< 500Hz Infrequent
1ms	Harness Coupling	< 200V	< 1J	Often
< 60ns	Electrostatic Discharge	< 15kV	< 10mj	Infrequent

As noted, there are dozens of applications that need circuit protection. They include USB ports, Ethernet ports, CANBus and LINBus lines, antenna, infotainment display interfaces, power systems, fuel injection management systems, and many more. Electrical transients present a top critical risk to damaging these systems. Electrical transients also increase servicing and warranty costs for auto manufacturers. Therefore, proper circuit protection is an important factor of any automotive design process. In addition, vehicle electronic systems will need to comply with automotive standards such as ISO 16750-2 (12V & 24V systems), MIL-STD-1275 (28V System), ISO 7637-2, ISO 10605 and the new ISO 21780 standard for 48V Systems.

There are many common transients in automotive systems that impact performance of the electronic systems. They can be generated from many different sources, from common electrostatic discharge, load dump, inductive switching and other electrical surges. ProTek Devices offers a variety of protection solutions.

SELECTION GUIDE		
APPLICATION	PREFERRED DEVICES	ALTERNATE DEVICES
Antenna	PAM02SD23xxC Series, PAM41TKDF2L0521	PAM01SC7905C, PAM03SD23xxCI Series
Battery (Load Dump)	PAM28DOACxxA/CA Series, PAM29DOAAxxA/CA Series, PAM30DOAAxxA/CA Series, PAM31DOABxxA/CA Series, PAM32DOABxxA/CA Series, PAM33DOABxxA/CA Series, PAM35DOABxxA/CA Series, PAM36DOAAxxA/CA Series, PAM39SDxxAL/CAL Series, PAM40SDxxBL/CBL Series	PAM4SMA Series, PAM5S Series, PAM6S Series, PAM8S Series
CANBus Classic	PAM1CAN, PAM2CAN	PAM3CAN, PAM10ST23xxC Series
CANBus FD (Flexible Data)	PAM3CAN, PAM3CAN36	
Control Buttons	PAM17DF2L05C	
Control Lines	PAM28DOACxxA/CA Series, PAM29DOAAxxA/CA Series, PAM30DOAAxxA/CA Series, PAM31DOABxxA/CA Series, PAM32DOABxxA/CA Series, PAM33DOABxxA/CA Series, PAM39SDxxAL/CAL Series, PAM40SDxxBL/CBL Series	PAM21SC790501H, PAM4SMA Series
Display	PAM13ST2305	
EV Charging Station	PAM02SD23xxC Series, PAM03SD23xxCI Series	30KPA345CA
GigabitE	PAM05SC700504F, PAM15ST4305, PAM251005	PAM12SO824
FlexRay Bus	PAM1CAN, PAM2CAN, PAM3CAN	PAM10ST23xxC Series
Fuel Injection System	PAM08SD23xxC Series, PAM10ST23xxC Series	
LinBus	PAM1LIN, PAM1VN27	PAM2LIN
Power Systems	PAM10ST23xxC Series, PAM5S Series, PAM6S Series, PAM7KSMDJ24CAP, PAM8S Series	PAM28DOACxxA/CA Series, PAM29DOAAxxA/CA Series, PAM30DOAAxxA/CA Series, PAM31DOABxxA/CA Series, PAM32DOABxxA/CA Series, PAM33DOABxxA/CA Series, PAM35DOABxxA/CA Series, PAM36DOAAxxA/CA Series,
USB 2.0	PAM15ST4305, PAM251005	PAM05SC700504F
USB Type-C	PAM251005	

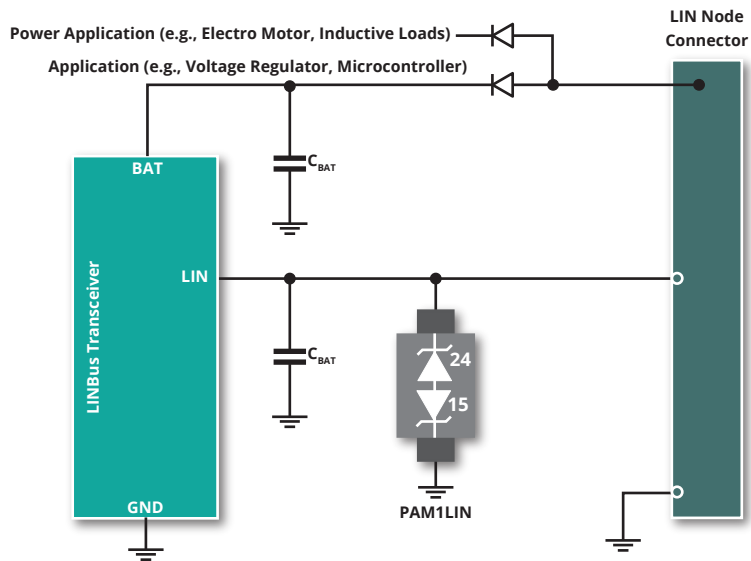

Figure 1. LINBus Protection Using PAM1LIN

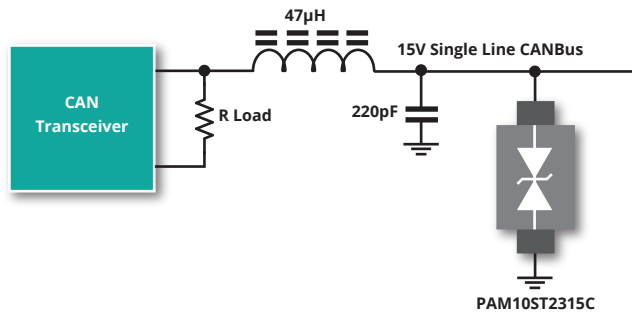

Figure 2. CANBus Protection Using PAM10ST2315C

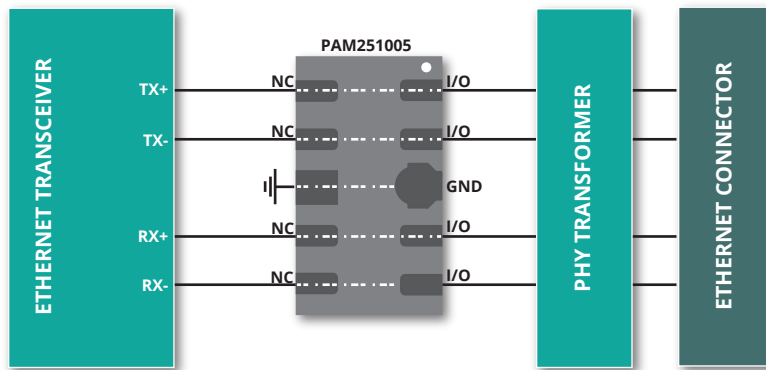

Figure 3. Gigabit Ethernet Protection Using PAM251005

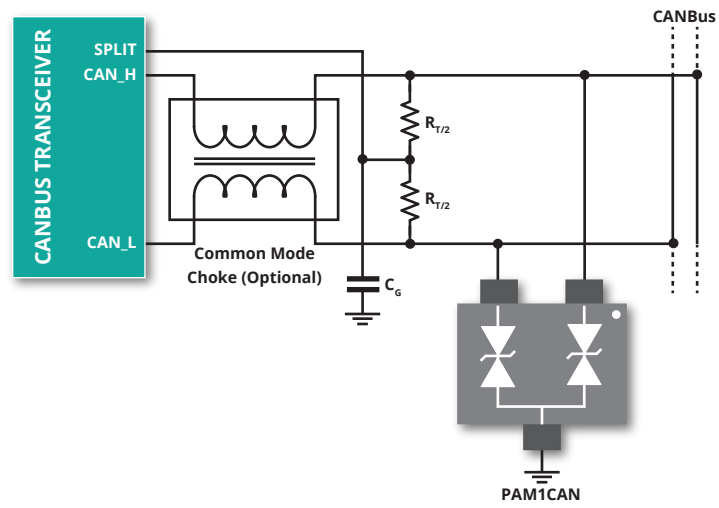

Figure 4. CANBus Protection Using PAM1CAN

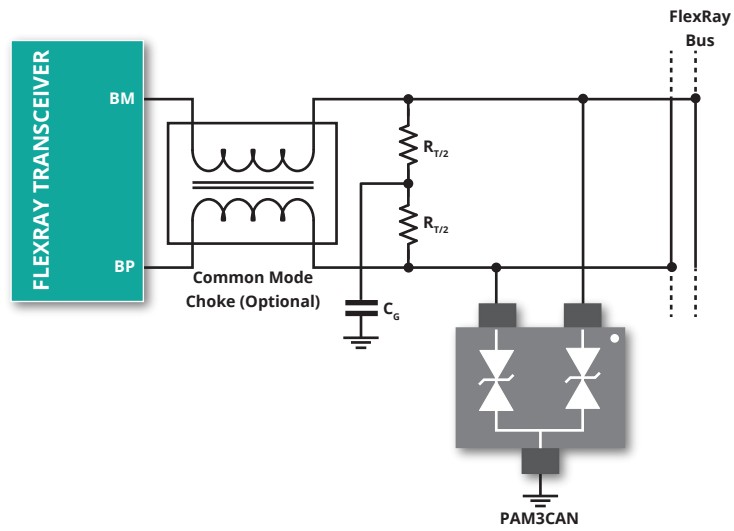

Figure 5. FLEXRay Bus Protection Using PAM3CAN



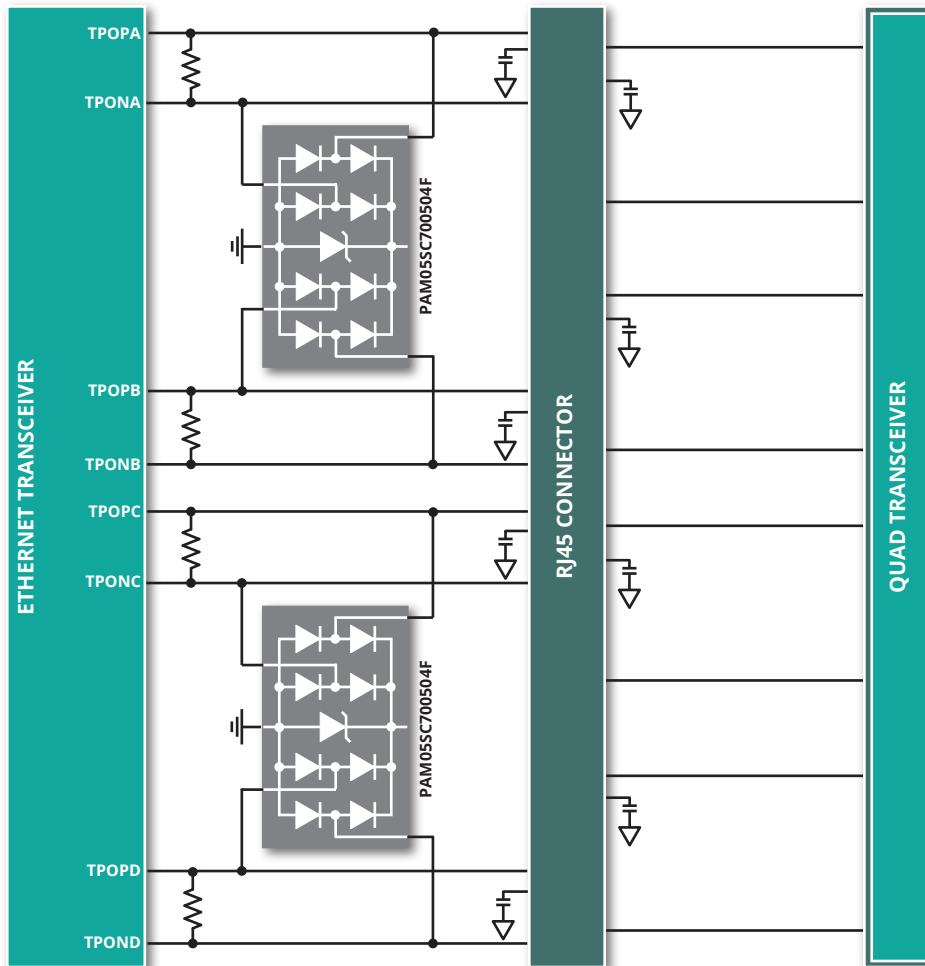

Figure 6. Gigabit Ethernet Protection Using PAM05SC700504F

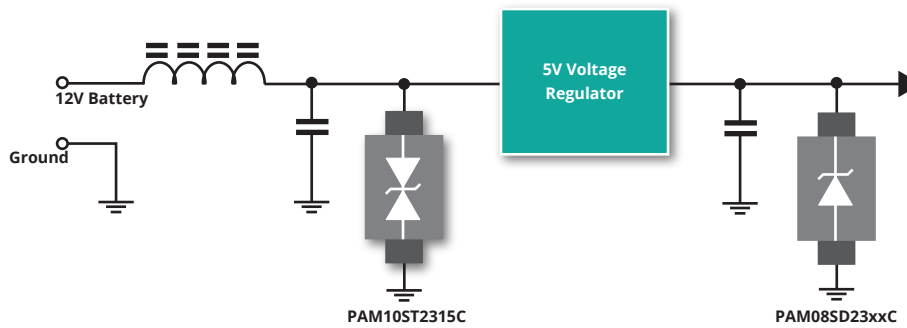

Figure 7. Power Systems Protection Using PAM10ST2315C and PAM08SD23xxC

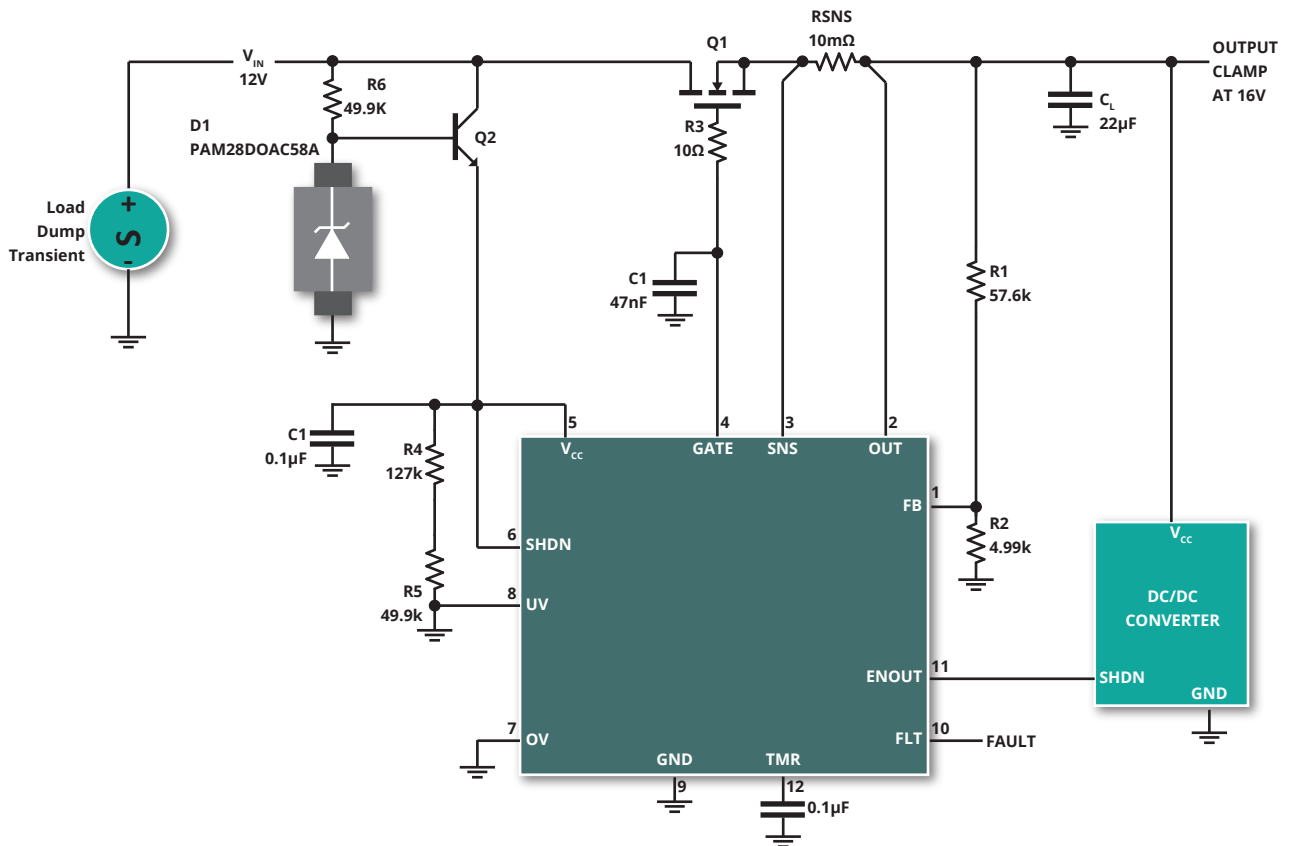

Figure 8. Battery (Load Dump) Protection Using PAM28DOAC58A

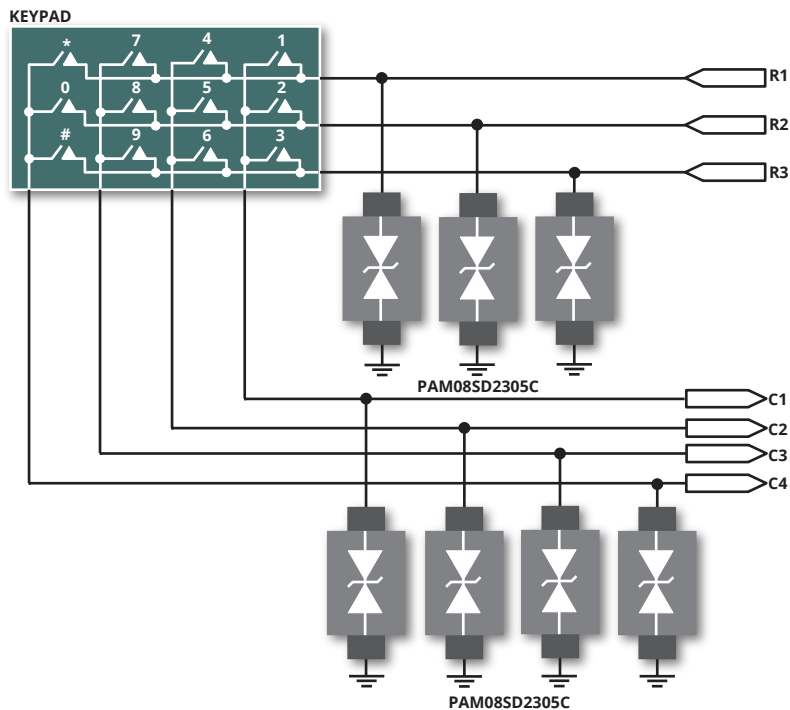

Figure 9. Control Button Protection Using PAM08SD2305C

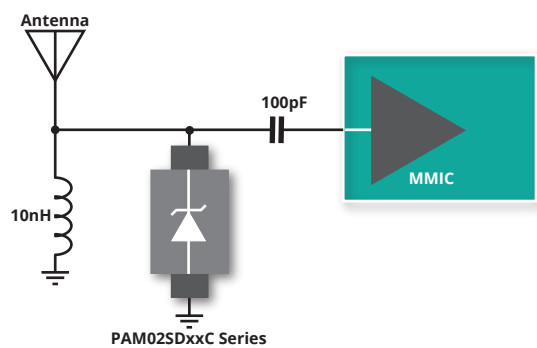

Figure 10. Antenna Protection Using PAM02SD23xxC

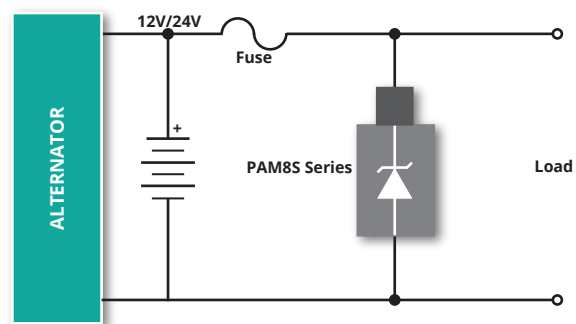

Figure 11. Load Dump Protection Using PAM8S Series

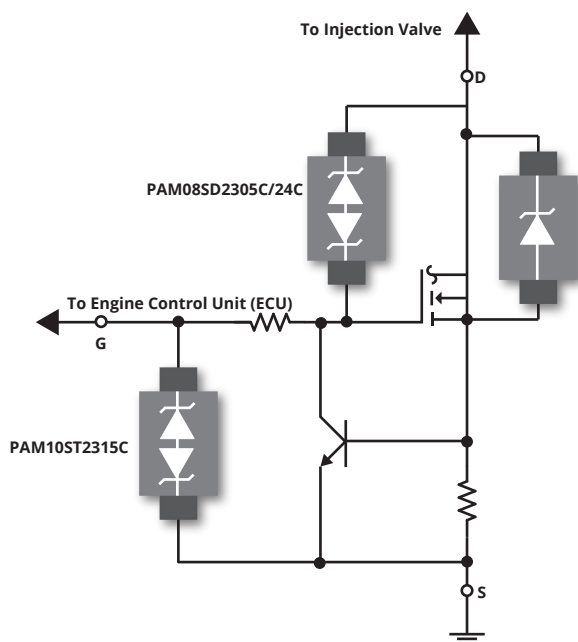

Figure 12. Fuel Injection Management System Protection Using PAM08SD2305C/24C and PAM10ST2315C



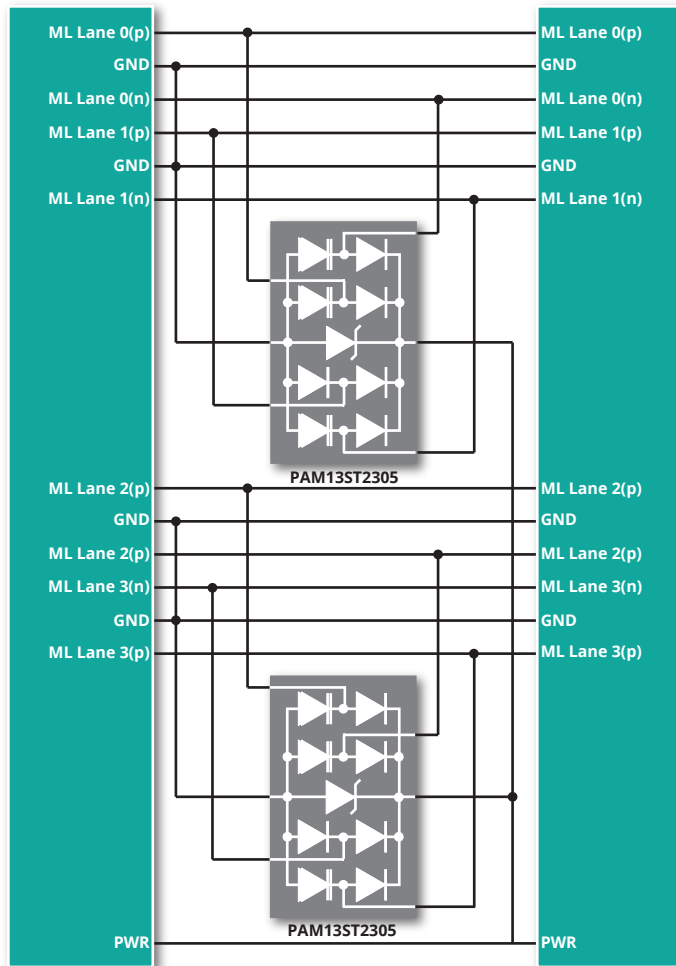

Figure 13. Display Protection Using PAM13ST2305

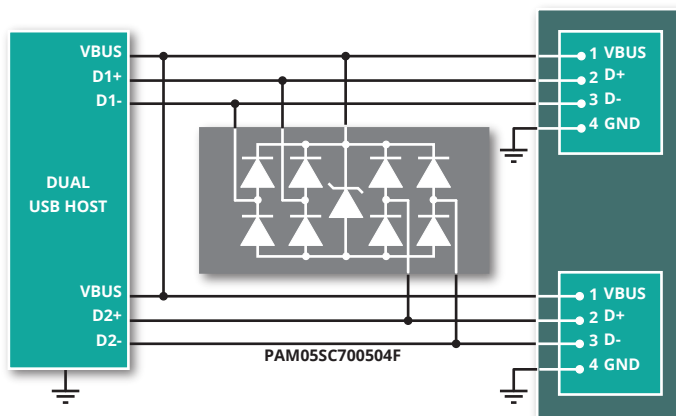

Figure 14. USB 2.0 Interface Protection Using PAM05SC700504F

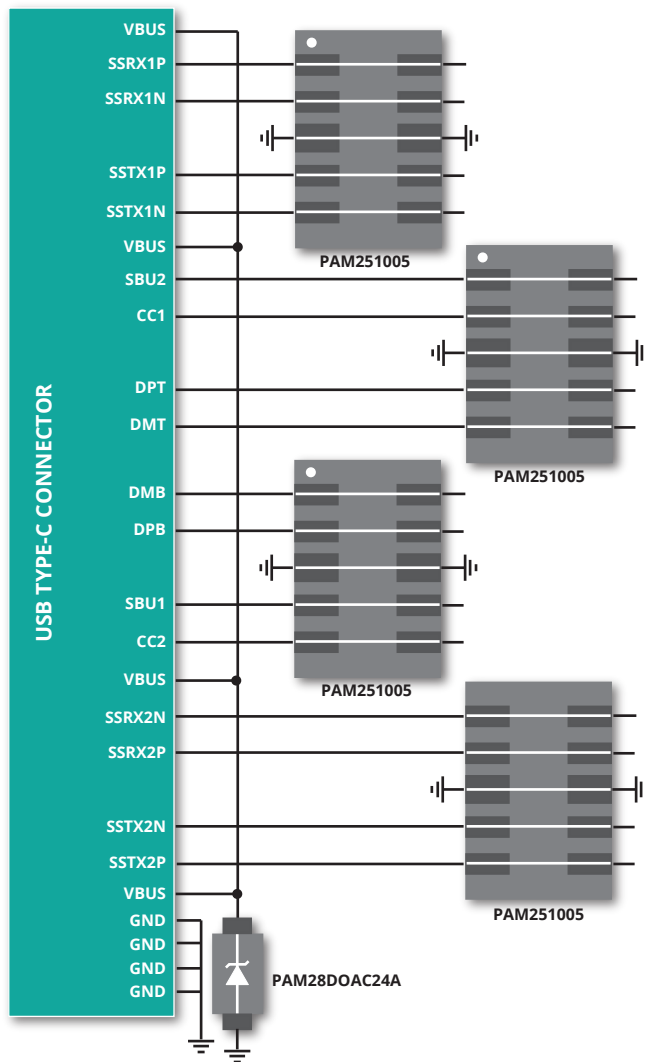
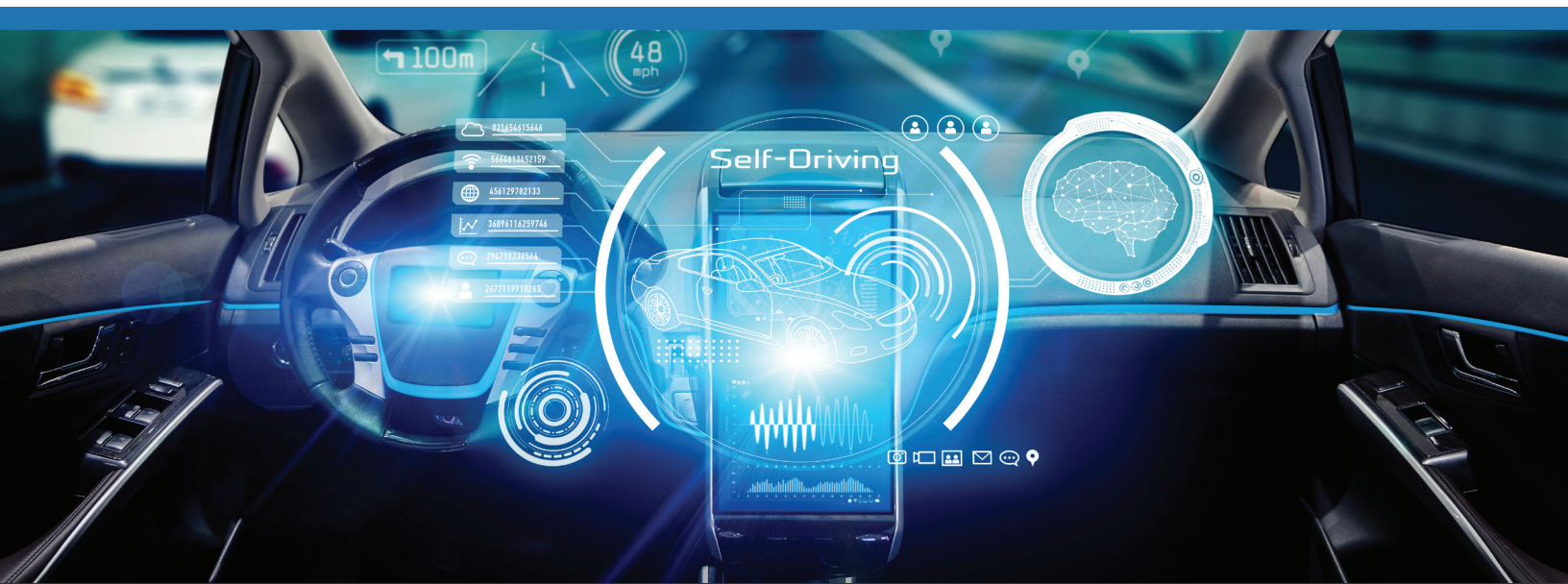

Figure 15. USB Type-C Protection Using PAM251005 and PAM28DOAC24A



SELECTION PROCESS

TVS PARAMETERS	APPLICATION PARAMETERS
Stand-Off Voltage (V_R) \geq	Operating Voltage (V_{OP})
Pulse Current (I_p) \geq	Transient Current (I_T)
Clamping Voltage (V_C) \leq	Voltage Withstand Level (V_{WS})
Input Capacitance of the Device \leq	Acceptable Line Loading for Functional Pass

Graph Symbols/Parameters

B_V - Breakdown Voltage
 I_R - Leakage Current
 V_R - Reverse Stand-Off Voltage
 V_C - Clamping Voltage
 I_{PP} - Peak Pulse Current

Avalanche Junction TVS VI Characteristics

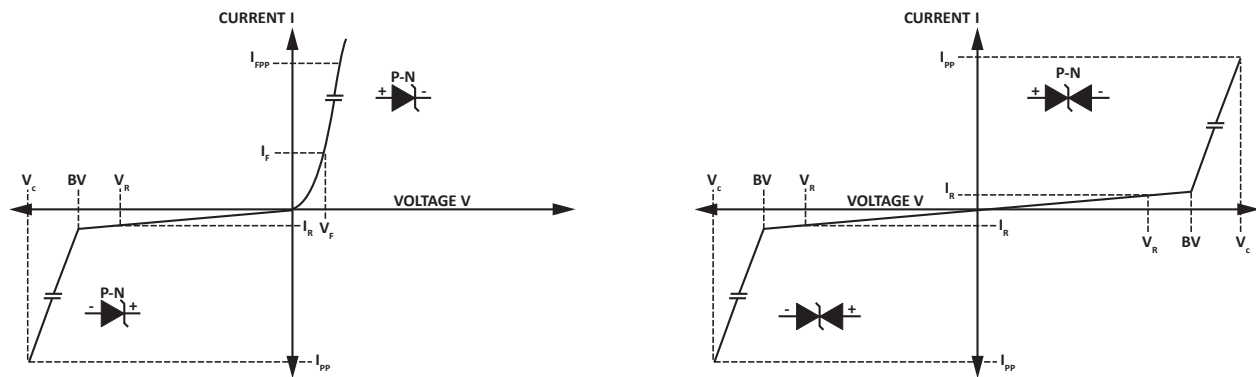

OVERVOLTAGE PART SPECIFICATIONS

PART NUMBER	STAND-OFF VOLTAGE	BREAKDOWN VOLTAGE	CLAMPING VOLTAGE	PEAK PULSE CURRENT	MAXIMUM LEAKAGE	TYPICAL CAPACITANCE	NO. OF LINES	POWER 8/20 μ s	PACKAGE
	V_{WM} VOLTS	$V_{(BR)}$ VOLTS	V_C VOLTS	8/20 μ s I_{PP} AMPS	CURRENT I_b μ A	C pF		WATTS	
PAM01SC7905C	5.0	6.0	16.0	10.0	1	1.5	1	200	SC-79
PAM02SD23xx/C	3.3-24.0	4.0-26.7	7.0-43.0	1.0	5-1	3	1	350	SOD-323
PAM03SD23xxCI	3.0-18.0	4.0-20.0	7.0-29.0	1.0	5-1	0.6	1	250	SOD-323
PAM05SC700504F	5.0	6.0	25.0	5.0	3	1.9	4	200	SC70-6L
PAM08SD23xx/C	3.3-36.0	4.0-40.0	6.5-60.0	1.0	125-1	500-35	1	400/500	SOD-323
PAM1CAN	24.0	25.4	70.0	3.0	0.05	11	2	200	SOT-23
PAM1IVN27	27.0	28.0	37.0	3.0	0.1	15	1	135	SOD-323
PAM1LIN	15.0/24.0	17.2/25.5	25.0/40.0	1.0	45	17	1	200	SOD-323
PAM2CAN	24.0	25.4	60.0	4.0	0.05	11	2	230	SOT-23
PAM2LIN	24.0	26.7	43.0	1.0	0.05	3.3	1	350	SOD-323
PAM3CAN	24.0	25.4	46.0	2.1	0.2	5	1	150	SOT-23
PAM3CAN36	36.0	37.0	56.0	1.0	0.05	6	1	80	SOT-23
PAM4SMA	11.1 - 470.3	12.4 - 522.5	18.2 - 759.0	22.5 - 0.53	1	-	1	400*	DO-214AC
PAM5Sxx	14.0-36.0	15.6-40.0	23.2-58.1	155-62	10	-	1	3600*	DO-218AB

Notes

1. I_{PP} and P_{PP} 10/1000 μ s.

OVERVOLTAGE PART SPECIFICATIONS

PART NUMBER	STAND-OFF VOLTAGE	BREAKDOWN VOLTAGE	CLAMPING VOLTAGE	PEAK PULSE CURRENT	MAXIMUM LEAKAGE	TYPICAL CAPACITANCE	NO. OF LINES	POWER 8/20 μ s	PACKAGE
	V _{WM} VOLTS	V _(BR) VOLTS	V _C VOLTS	8/20 μ s I _{PP} AMPS	CURRENT I _D μ A	C pF		WATTS	
PAM6Sxx	14.0-36.0	15.6-40.0	23.2-58.1	198-79	10	-	1	4600*	DO-218AB
PAM7KSMDJ24CAP	24.0	26.7	28.0	200	1	-	1	7000*	DO-214AB
PAM8Sxx	14.0-43.0	15.6-47.8	23.2-69.4	284-95.1	10	-	1	6600*	DO-218AB
PAM10ST23xxC	8.0-24.0	8.5-26.7	16.9-49.0	34.0-12.0	10-1	150-63	1	500	SOT-23
PAM11KLD8S24CAP	24.0	26.7	26.0	300.0	10	-	1	1100*	DO-218AB
PAM12SO824	2.8	3.0	21.0	30.0	10	3	2P	600	SO-8
PAM12VCAN	12.0	13.3	19.0	1.0	1	30	1	350	SOT-23
PAM13ST2305	5.0	6.0	15.0	5.0	5	3.5	4	500	SOT-23-6
PAM15ST4305	5.0	6.0	20.0	28.0	5	10	2	500	SOT-143
PAM17DF2LC05C	4.7	5.7	-	-	1	15	1	10*	DFN-2
PAM21SC790501H	5.0	6.0	12.5	16.0	5	120	1	250	SC-79
PAM251005	5.0	6.0	10.0	1.0	1.0	0.5	4	100	DFN-10
PAM251033	3.3	3.8	9.0	1.0	1.0	0.33	4	30	DFN-10
PAM28DOACxxA/CA	12.0-120	13.3-147.0	19.9-193.0	20.1-2.1	1	-	1	400*	DO-214AC
PAM29DOAAxxA/CA	24.0-36.0	26.7-40.0	38.9-58.2	15.4-10.3	1	-	1	600*	DO-214AA
PAM30DOAAxxA/CA	5.8-513.0	6.46-570.0	10.5-828.0	57.1-0.72	1	-	1	600*	DO-214AA
PAM31DOABxxA/CA	24.0-33.0	26.7-36.7	38.9-53.3	38.6-28.1	1	-	1	1500*	DO-214AB
PAM32DOABxxA/CA	36.0	40.0	58.1	51.6	2	-	1	3000*	DO-214AB
PAM33DOABxxA/CA	24.0-36.0	26.7-40.0	43.0-58.1	117-86.9	5	-	1	5000*	DO-214AB
PAM35DOABxxA/CA	5.8 - 256.0	6.45 - 285.0	10.5 - 414.0	144.8 - 3.7	1	-	1	1500*	DO-214AB
PAM36DOAAxxA/CA	18.0 - 36.0	20.0 - 40.0	29.2 - 58.1	34.3 - 17.3	1	-	1	1000*	DO-214AA
PAM37SDxxAL/CAL	6.0 - 58.0	6.67 - 64.40	10.3 - 93.6	35.9 - 4.1	120 - 1	-	1	400	SOD-123FL
PAM39SDxxAL/CAL	10.0 - 85.0	11.10 - 94.4	17.0 - 137.0	23.5 - 2.9	1	-	1	400*	SOD-123
PAM40SDxxBL/CBL	10.0 - 220.0	11.10 - 246.0	17.0 - 356.0	11.8 - 0.5	1	-	1	200*	SOD-123
PAM41TKDF2L0521	5.5	6.0	25.0	4.0	0.1	0.25	1	100	DFN-2

Notes

1. I_{pp} and P_{pp} 10/1000 μ s.

COMPANY PROFILE

In business more than 30 years, ProTek Devices™ is a privately held semiconductor company. The company offers a product line of overvoltage protection that include Transient Voltage Suppressor (TVS) Arrays, Steering Diode Array Hybrids, High-power Components and Modules, as well as Steering Diodes, EMI Filter/TVS Arrays and Thyristor Surge Suppressors. These components deliver circuit protection in electronic systems from numerous overvoltage events. They include lightning; electrostatic discharge (ESD); nuclear electromagnetic pulses (NEMP); inductive switching; and electromagnetic interference (EMI) / radio frequency interference (RFI). ProTek Devices is an ISO 9001 certified company.

CONTACT US

Corporate Headquarters

2929 South Fair Lane
Tempe, Arizona 85282
USA

By Telephone

General: 602-431-8101
Sales: & Marketing: 602-414-5109
Customer Service: 602-414-5114
Product Technical Support: 602-414-5107

By Fax

General: 602-431-2288

By E-mail:

Asia Sales: asiasales@protekdevices.com
Europe Sales: europesales@protekdevices.com
U.S. Sales: ussales@protekdevices.com
Distributor Sales: distysales@protekdevices.com
Customer Service: service@protekdevices.com
Technical Support: support@protekdevices.com

Web

www.protekdevices.com

ROHS & REACH COMPLIANCE

All devices, with the exception the modules/axial leads are Lead-Free, RoHS & REACH compliant. These products are designated as "lead free" and meet the requirements of the European Union's restriction on the use of hazardous substances in electrical equipment as stated in (RoHS) direction, 2002/95/EC. ProTek Devices defines "lead free" as products that are compatible with current RoHS requirements for the 6 "banned" substances: Lead (Pb, <1000ppm), Cadmium (Cd, <100ppm), Mercury (Hg, <1000ppm), Hexavalent Chromium (Cr6+, <1000ppm), Poly Brominated Biphenyls (PPB, <1000ppm), Poly Brominated Diphenyl Ethers (PBDE, <1000ppm). This includes the requirements that lead not exceed 0.1% by weight in homogeneous materials.

COPYRIGHT © ProTek Devices (2026) - This literature is subject to all applicable copyright laws and is not for resale in any manner.

SPECIFICATIONS: ProTek Devices reserves the right to change the electrical and or mechanical characteristics described herein without notice.

DESIGN CHANGES: ProTek Devices reserves the right to discontinue product lines without notice and that the final judgment concerning selection and specifications is the buyer's and that in furnishing engineering and technical assistance. ProTek Devices assumes no responsibility with respect to the selection or specifications of such products. ProTek Devices makes no warranty, representation or guarantee regarding the suitability of its products for any particular purpose, nor does ProTek Devices assume any liability arising out of the application or use of any product or circuit and specifically disclaims any and all liability without limitation special, consequential or incidental damages.

LIFE SUPPORT POLICY: ProTek Devices products are not authorized for use in life support systems without written consent from the factory.