



常州银河世纪微电子股份有限公司
Changzhou Galaxy Century Microelectronics Co., Ltd.

总部地址 .Add
中国江苏省常州市新北区长江北路 19 号
No.19 Changjiang North Road, Xinbei District,
Changzhou, Jiangsu, China.

电话 .Tel
0086-519-6885 1188

传真 .Fax
0086-519-8512 0202

Email: info@gmesemi.com
Website: www.gmesemi.com

境内销售 .Mainland China Sales

电话 .Tel
0086-519-6885-9188
0086-519-6885-9168

Email:
sales@gmesemi.com

海外销售 .Overseas Sales

电话 .Tel
0086-519-6885-9188

Email:
sales@gmesemi.com

技术支持 .Technical Support

电话 .Tel
0086-519-6885-9161

Email:
support@gmesemi.com



©2025 Changzhou Galaxy Century Microelectronics Co., Ltd.
本手册所列产品外观、颜色、参数等仅供参考，请以公司所发实物及技术文件为准。
我公司保留随时修改或取消本手册资料相关参数并不预先告知的权利。
更多信息请登陆我公司网站 www.gmesemi.com 或请与我公司联系。

Integrated Device Manufacturer of Discrete Semiconductor

半导体分立器件专业制造商



Stock Code
688689.SH

常州银河世纪微电子股份有限公司
Changzhou Galaxy Century Microelectronics Co., Ltd.



致力于成为世界知名的 半导体分立器件供应商

To Be the World-Class Semiconductor Supplier



CNAS

国际标准实验室
International
Standards Laboratory



AEC

国际汽车电子协会成员
The Member of AEC
(Automotive
Electronics Council)



30+Years

丰富行业经验
Solid Foundation



1,300+

员工人数
Employees



100,000+

工厂面积/m²
Area/m²

1964-1994

- 1964 - 常州无线电元件七厂成立
- 1985 - 生产军用、民用二极管、三极管
- 1994 - 常州银河电器有限公司成立
投资4吋晶圆生产线

1964 - Changzhou 7th Radio Component Factory established

1985 - Mass Production of Military and Commercial Diodes and Transistors

1994 - Changzhou Galaxy Electrical Co., Ltd

Investment in 4 inch Wafer Production Line

1994-2006

- 2006 - 香港主板上市 HK0527
常州银河世纪微电子有限公司成立
投资6吋晶圆生产线

2006 - Galaxy Semiconductor Holdings HK Stock Exchange Listed - HK0527

Changzhou Galaxy Century Microelectronics Co., Ltd. established

Investment in 6 inch Wafer Production Line

2006-2018

- 2007 - 规模化生产车规产品
- 2014 - 8吋MOSFET晶圆流片成功
- 2018 - 正式加入国际汽车电子协会技术委员会

2007 - Large-scale Production of Automotive Grade Products

2014 - 8 inch MOSFET Wafer Mass Production

2018 - Officially joined the AEC Technical Committee

2018-2024

- 2021 - 上海科创板IPO, 股票代码: 688689
12吋MOSFET晶圆流片成功
- 2022 - 独立车规产线量产

2021 - Shanghai STAR Market IPO, Stock code: 688689

12 inch MOSFET Wafer Mass Production

2022 - Independent Automotive Production Line Mass Production

Product Application

全车产品应用

动力传动系统 Powertrain System

- DC/DC (12V/24V/48V)
- 水泵、燃油泵
Water & Fuel Pump
- 电动增压系统
Electric Boosting System

车载信息娱乐 In-Vehicle Infotainment

- 汽车仪表
Automotive Instrument Cluster
- 车载音响/音影
In-Car Audio/Visual System
- 车载导航GPS
In-Car Navigation GPS

热管理系统 Thermal Management System

- 电子风扇驱动系统
Electronic Fan Drive System
- 空调系统
Air Conditioning System
- PTC加热器
PTC Heater
- ECU控制器
ECU Controller

电源系统 Power System

- 电池管理系统BMS
Battery Management System (BMS)
- 车载充电机OBC
On-Board Charger (OBC)
- 车载无线充
On-Board Wireless Charging

汽车网络 Automotive Networking

- CAN/LIN BUS
- Bluetooth, Wi-Fi
- USB

域控制器 Domain Controller

- 汽车左/右域控系统
Automotive Left/Right Domain Control System
- 智能驾舱域控系统
Intelligent Cockpit Domain Control System
- 底盘域控系统
Chassis Domain Control System

高级辅助驾驶系统ADAS Advanced Driver Assistance Systems (ADAS)

- ADAS毫米波雷达
ADAS Millimeter-Wave Radar
- ADAS激光雷达
ADAS Lidar
- ADAS智能摄像
ADAS Intelligent Cameras
- ADAS电子控制
ADAS Electronic Control

汽车照明 Automotive Lighting

- LED前大灯/ADB控制
LED Front Headlights / ADB Control
- LED日行灯
LED Daytime Running Lights
- 汽车尾灯
Automotive Tail Lights
- 转向刹车信号灯
Turn Signal and Brake Lights



IATF 16949
Certified

AEC-Q101
Qualified

ISO26262
Function
Safety

IGBT

IGBT

电压. Voltage	电流. Current	开关频率. Switching Frequency	IGBT系列. IGBT Series	典型应用. Typical Application
650V	4 to 20A	8 to 30kHz	H	Home Appliances
	20 to 80A	50 to 100kHz	V	Welding, PFC, Solar, UPS, Charger
	4 to 200A	2 to 20kHz	M	Industrial Motor Control, Automotive Traction Inverter, GPI, A/C
	20 to 80A	16 to 60kHz	HB	PFC, Solar, UPS, Charger Welding and Soft Switching
	15 to 100A		HB2	
	20 to 50A		IH	
1200V	40A	2 to 20kHz	MS	Motor Control, Aux Loads, PTC Heaters, Battery Thermal Mgmt
	8 to 75A		M	Industrial Motor Control, GPI, A/C
	15 to 75A	20 to 100kHz	H	PFC Welding, Solar, UPS, Charger
1350V	20A, 30A	16 to 60kHz	IH	Induction Heating, Microwave and Soft Switching
	25A, 35A		IH2	



ITO-220AB

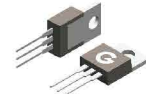

TO-220AB



TO-247

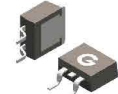

TO-263



TO-252

IGBT Module

封装平台. Package Platform	封装说明. Package Specification	主要应用. Chief Application	产能(K/月). Production Capacity (K/month)
S系列. S series	SOT227/34mm/62mm etc.	焊机/感应加热/工业电源等 Welding Machine/Induction Heating/ Industrial Power Supply, etc	100
E系列. E series	Easy 1B/2B/3B etc.	变频器/伺服/光伏 Inverter/Servo/PV	50
C系列. C series	Econo Pack2/PIM3/PACK4 etc.	变频器/伺服/汽车空调 Drives/Servo/Car Air Conditioning	40
Q系列. Q series	Q1/Q2	光伏/储能PCS PV/Energy Storage PCS	10
U系列. U series	HPD/HP1	新能源车主驱 EV Inverter	10



34mm 62mm SOT-227 Easy1B Easy2B Q1 Q2 Econo Dual3 Econo Pack3 Econo Pack2 Econo PIM3

IPM 智能功率模块



高集成度

我们的IPM模块集成了功率开关、控制IC、保护电路等，为您提供了无与伦比的设计灵活性和效率。

High-degree Integration

Our IPM module seamlessly integrates power switches, control ICs, protection circuits, etc., offering you exceptional design flexibility and efficiency.

紧凑的封装设计

紧凑的封装设计不仅节省了空间，还降低了成本，同时简化了设计过程，加速了您的产品上市。

Compact Package Design

Compact packaging design not only optimizes space and reduces costs but also streamlines the design process, accelerating your product's time to market.

高可靠性

通过针对用途的性能优化，我们的IPM确保了在各种应用中的卓越效率和坚如磐石的可靠性。

High Reliability

By optimizing performance for specific applications, our IPM delivers exceptional efficiency and unwavering reliability across diverse use cases.

灵活的封装方式

选择我们的三相全桥或半桥封装，以满足您的特定需求。让我们的IPM成为您下一个项目的关键驱动力。

Flexible Packaging

Select our three-phase full-bridge or half-bridge packages to address your specific needs, and let our IPM serve as the key driver for your next project.

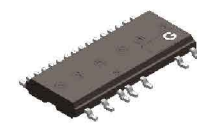
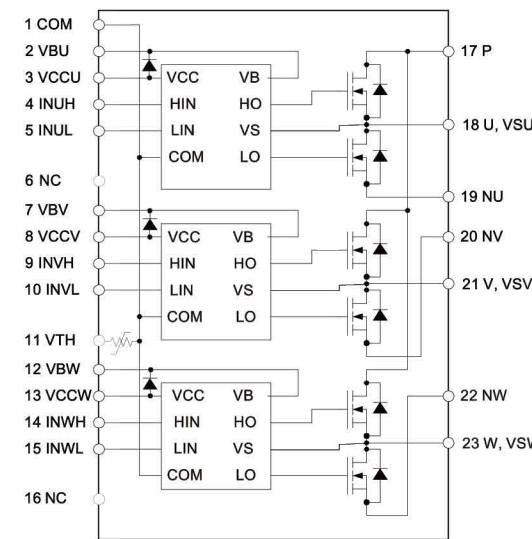

SOP23H



DIP-25B

应用领域:

风扇/水泵/洗碗机/冰箱/空调/电动工具等

Application:

Fan/Water Pump/Dishwasher/Refrigerator/
Air Conditioner/Power Tools, etc



SiC Schottky Diodes

产品平台 Platform	产品名称 PN	Voltage (V)	Current (A)	Package
650V	GSC2D0265D	650	2	TO-252
	GSC2D0465D	650	4	TO-252
	GSC2D0465	650	4	TO-220
	GSC2D0665D	650	6	TO-252
	GSC2D0665	650	6	TO-220
	GSC2D0865	650	8	TO-220
	GSC2D1065	650	10	TO-220
	GSC2D1065D	650	10	TO-252
	GSC2D1065F	650	10	ITO-220
	GSC2D1665U	650	16	TO-247-2
	GSC2D2065BN	650	20	TO-263
	GSC2D2065	650	20	TO-220
	GSC2D3065	650	30	TO-220
	1200V	GSC2D02120D	1200	2
GSC2D02120		1200	2	TO-220
GSC2D10120		1200	10	TO-220
GSC2D10120B		1200	10	TO-263
GSC2D15120U		1200	15	TO-247-2
GSC2D20120U		1200	20	TO-247-2
1700V ※	GSC2D30120U	1200	30	TO-247-2
	GSC2D40120U	1200	40	TO-247-2
	GSC2D10170U	1200	10	TO-247-2
	GSC2D25170U	1200	25	TO-247-2

Advantages

- 零 I_{RR}
- 高 I_{FSM}
- 出色的品质因数(Q_c×V_F)
- 可以并联
- T_J高达175°C
- 更高功率密度
- 更高的工作频率
- 更小的EMI
- Zero I_{RR}
- High-degree I_{FSM}
- Excellent Quality Factor (Q_c×V_F)
- Parallel Connection
- T_J up to 175°C
- Higher Power Density
- Higher Operating Frequency
- Less EMI

应用领域:

电车充电站和车载充电机/光伏发电系统/储能系统/通信电源/轨道交通/高功率密度电源适配器

Application:

EV Charging Station, OBC/Photovoltaic Power System/ Energy Storage System/Communication Power Supply/ Rail Transit/Power Adapter with High Power Density

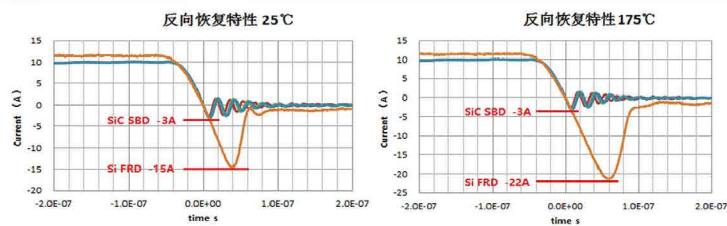

SiC-SBD器件的反向恢复电流明显小于Si-FRD器件，且几乎不受温度的影响
The reverse recovery current of SiC-SBD devices is significantly lower than that of Si-FRD devices and is almost unaffected by temperature.

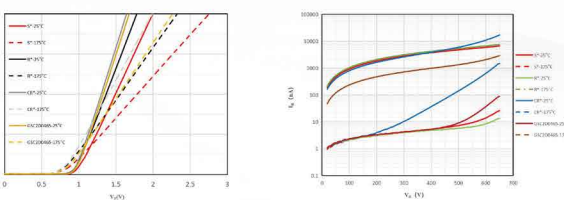

$V_F \cdot CR^* < GME < R^* < S^*$
 $IR \cdot R^* < S^* < GME < CR^*(25^\circ C)$
 $GME < S^* < R^* < CR^*(175^\circ C)$



SiC MOSFETs

产品类别 Category	BV _{DSS} (V)	R _{DS(on)} (mΩ)	产品名称 PN			
			TO-247-3	TO-263-7	TO-247-4	TOLL
6" SiC MOSFET	1200	6	-	-	GSC120R006U4	-
		12	GSC120R012U	GSC120R012B7	GSC120R012U4	GSC120R012-TL
		16	GSC120R016U	GSC120R016B7	GSC120R016U4	GSC120R016-TL
		30	GSC120R030U	GSC120R030B7	GSC120R030U4	GSC120R030-TL
		40	GSC120R040U	GSC120R040B7	GSC120R040U4	GSC120R040-TL
		60	GSC120R060U	GSC120R060B7	GSC120R060U4	GSC120R060-TL
	750	9	GSC75R009U*	GSC75R009B7*	GSC75R009U4*	GSC75R009-TL*
		22	GSC75R022U*	GSC75R022B7*	GSC75R022U4*	GSC75R022-TL*
		42	GSC75R042U*	GSC75R042B7*	GSC75R042U4*	GSC75R042-TL*
		60	GSC75R060U*	GSC75R060B7*	GSC75R060U4*	GSC75R060-TL*
		5	-	-	GSC120R005U4*	-
		10	GSC120R010U*	GSC120R010B7*	GSC120R010U4*	GSC120R010-TL*
	1200	13	GSC120R013U*	GSC120R013B7*	GSC120R013U4*	GSC120R013-TL*
		25	GSC120R025U*	GSC120R025B7*	GSC120R025U4*	GSC120R025-TL*
		50	GSC120R050U*	GSC120R050B7*	GSC120R050U4*	GSC120R050-TL*
		15	GSC170R015U*	-	GSC170R015U4*	-
		20	GSC170R020U*	-	GSC170R020U4*	-
		40	GSC170R040U*	-	GSC170R040U4*	-
1700	1000	GSC170R1K0U*	-	GSC170R1K0U4*	-	
	3000	GSC170R3K0U*	-	GSC170R3K0U4*	-	



*"为规划产品型号，实际型号以量产型号为准

Advantages

- 可以并联
- 低 R_{DS(on)}
- 开关损耗小
- 高温漏电流低
- 高频高效提升整体性能
- Parallel Connection
- Low-degree R_{DS(on)}
- Low Switching Loss
- Low Leakage at High Temperature
- Performance Enhancement

应用领域:

电车充电站和车载充电机/充电桩/光伏逆变器/UPS电源/通信电源

Application:

EV Charging Station, OBC/ PV Inverter/UPS/ Communication Power Supply

GaN

GaN HEMTs

产品型号 PN	制程工艺 Technology	RDS(on) Typ. (mΩ)	封装外形 Package Outline
GAN65RXX ※	GaN-on-Si, E-Mode	70	DFN8×8/TOLL
GAN65RXX ※	GaN-on-Si, E-Mode	120	DFN8×8/TOLL
GAN65R240XX	GaN-on-Si, E-Mode	160	DFN8×8/DFN5×6
GAN65RXX ※	GaN-on-Si, E-Mode	240	DFN8×8/DFN5×6
GAN65RXX ※	GaN-on-Si, E-Mode	470	DFN5×6

※"代表产品尚在研发中，完整型号暂未确定 The symbol "※" represents that the products is still under the R&D, and the complete model number has not been finalized yet.

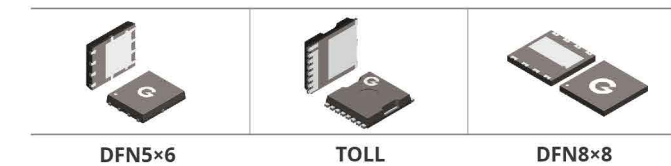

应用领域:

功率开关模组/PD快充、电源适配器/便携式储能/通信、服务器电源

Application:

Power Switch Module /PD Fast Charger, Power Adapter/ Portable Energy Storage/Communication, Server Power

GaN SBDs

Parameters(2A/4A/8A SBD)		
Parameters	Value	Unit
V _{DC}	650	V
I _F	2/4/8	A
V _{F@4A}	1.25	V
I _{leak@650V}	1	uA

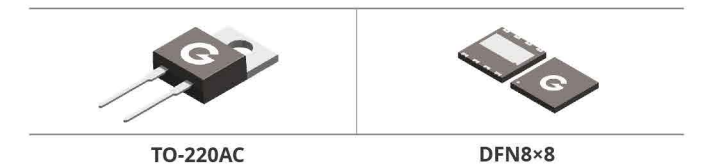

应用领域:

电源适配器/TV、家电/通信、服务器电源/光伏逆变/户用储能

Application:

Power Adapter /TV, Home Appliances/Communication, Server Power/Photovoltaic Inverter/Household Energy Storage

MOSFETs

		V_{DS}	V_{GS}	I_D	P_D	$R_{DS(on)}$ Typ.	
中低压MOSFETs LV&MV MOSFETs	P-Channel	-100V~-12V	$\pm 6V \sim \pm 25V$	-0.13A~-160A	0.15W~167W	3.2m Ω ~2 Ω	
	N-Channel	Low voltage	20V~55V	$\pm 8V \sim \pm 20V$	0.3A~328A	0.15W~250W	0.6m Ω ~1.2 Ω
		Medium voltage	60V~240V	$\pm 12V \sim \pm 20V$	0.17A~375A	0.2W~417W	0.78m Ω ~3.5 Ω
高压MOSFETs High Voltage MOSFETs	VD MOSFETs	250V~1500V	$\pm 20V \sim \pm 30V$	1A~90A	3W~830W	25m Ω ~8.7 Ω	
	Super Junction MOSFETs	500V~900V	$\pm 20V \sim \pm 30V$	1A~70A	25W~500W	40m Ω ~2.2 Ω	

SOT-23

SOT-363

PDFN5x6-8LC

TO-252

ToLL

Diodes

肖特基二极管. Schottky Diodes	MBRxx.series	V_{RRM}	I_F	I_{FSM}				
	SBTxx.series							
	SS/SLxx.series							
快恢复二极管. Fast Recovery Diodes	MURxx.series	V_{RRM}	I_F	I_{FSM}	T_{RR}			
	USFxx.series							
	SFxx.series							
	RSxx.series							
	HERxx.series							
	SOD1xx.series							

Protection Diodes

ESD/TVS保护管. ESD Protection Diodes Transient Voltage Suppressor	GESDxx.series	V_{RRM}	I_{PP}	P_{PP}		
	DLCxx.series					
	SDxx.series					
	SMAJ/BJ/CJxx.series					
1.5KExx.series	DFN3020-6L	SMC				
稳压二极管. Zener Diodes	BZT52xx.series	V_z	P_D			
	PDZxx.series					
	BZG03CXX.series					
	1N47/52/59xx.series					
	SMAJ/BJ/CJ59xx.series					

Transistors

		BV_{CEO}	I_c	h_{FE}	$V_{CE(sat)}$ Max	P_D
双极型晶体管. Bipolar Transistors	MMBT****.series	15V~450V	50mA~1A	40~400	0.25V~1.6V	0.15W ~2W
	2SB****.series	20V~100V	1A~5A	60~400	0.3V~1.2V	
	GT****.series	30V~140V	1A~5A	40~700	0.15V~0.37V	
达林顿晶体管. Darlington Transistors	TIP1****.series	100V	2A~10A	1000+	2V~4V	
数字晶体管. Digital Transistors	DTA/DTC****CA.series	BV_{CEO}	I_c	GI	$R1 \& R2$ (k Ω)	P_D
		50V	100mA	33~600	1~47	100mW
	DTB/DTD****CA.series	50V	500mA	39~600	1~47	~200mW

SOT-23

SOT-363

SOT-223

Analog & Digital ICs

		$V_{REF}(V)$	$V_{KA}(V)$	$I_{KA}(mA)$		
电压基准. Voltage Reference	BL431.series	2.5	36	100		
	BL432.series	1.24	15			
线性三端 稳压电路. Linear Three-Terminal Voltage Regulator Circuit	BL78.series	$3.3 \sim 24$	0.1~1.5	30~40		
	BL79.series	$-5 \sim -24$	0.15~1.5	-35		
	LM317.series	40	0.8~1.5	40		
	BLA1117.series	1.5~5/ADJ	0.8~1	15~20		
低压差线 性稳压器. LDO	PS1117.series	1.5~5/ADJ	0.8	15		
	BL75.series	3.3~5	0.1	24		

Bridge Rectifiers

		I_o	V_{RRM}		
插件.DIP	GBS.series / GBL.series	2~35A	max	GBS	GBJ
	GBU.series / KBJ.series / GBJ.series				
贴片.SMD	LB.series / MBF/MMB.series	1~8A	20~		
	TBS/TBF.series / TDF.series / 3SPB.series				



- 无触点、低触发、隔离性能好、抗干扰能力强、体积小、工作稳定、寿命长。
- 产品功能品类齐全、封装产品线齐全。
- 广泛应用于电源、家电、工业自动化、通信、医疗、光伏、汽车新能源等领域。
- 最高工作温度125°C，符合工规、车规温度标准。
- 通过VDE、UL、CQC安规认证。

- Non-contact, low triggering, good isolation performance, strong anti-interference capability, small size, stable operation, and long lifespan.
- The product provides a full range of functionalities and packaging options.
- Widely used in power supplies, home appliances, industrial automation, communications, medical, photovoltaic, and automotive new energy sectors.
- Maximum operating temperature of 125°C, meeting industrial and automotive temperature standards.
- VDE、UL、CQC Certification.

产品系列. Product	典型型号. Typical Model	封装系列. Package Series
晶体管系列. Transistor	BL814\BL816\BL817\BL851\BL4NXX-\ \BL354\BL357\BL3H4\BL3H7\BL8801\BL 101XH\BL101X\BLQ3H4\BLQ3H7	DIP4\DIP6\DIP8\SMD4\ SMD6\SM8\SOP4\ SSOP4\SSOP16\SOP4
可控硅系列. Triac	BL302X\BL305X\BL306X\BL308X\ BLM305X\BLM306X	DIP4\DIP5\DIP6\SMD4\ SMD5\SMD6\SOP4
光MOS继电器系列. PhotoMos Relay	BLY214\BLY216\BLW214\BLW216\ BLY214S\BLY216S\BLV258	DIP4\DIP6\DIP8\SMD4\SMD6\SM8\SOP4\ SSOP4\SOP16
高速光耦系列. High-speed Optocoupler	BL6N135\BL6N136\BL6N137\BL51X\ BL61X\BL0601\BL0631\H11L1	DIP8\SM8\SOP6\ SOP8\SMD6
栅极驱动光耦系列. Gate Driver Optocoupler	BL314\BL341\BL343\ BL3120\BL155	DIP8\SMD8\ SOP5\SOP6
IPM光耦. IPM Optocoupler	BL480\BL4506	SOP6\DIP8\SMD8
达林顿光耦. Darlington Optocoupler	BL815\BL852\BL451\BL452\BL4NXX	DIP4\DIP6\SMD4\SMD6\SOP4

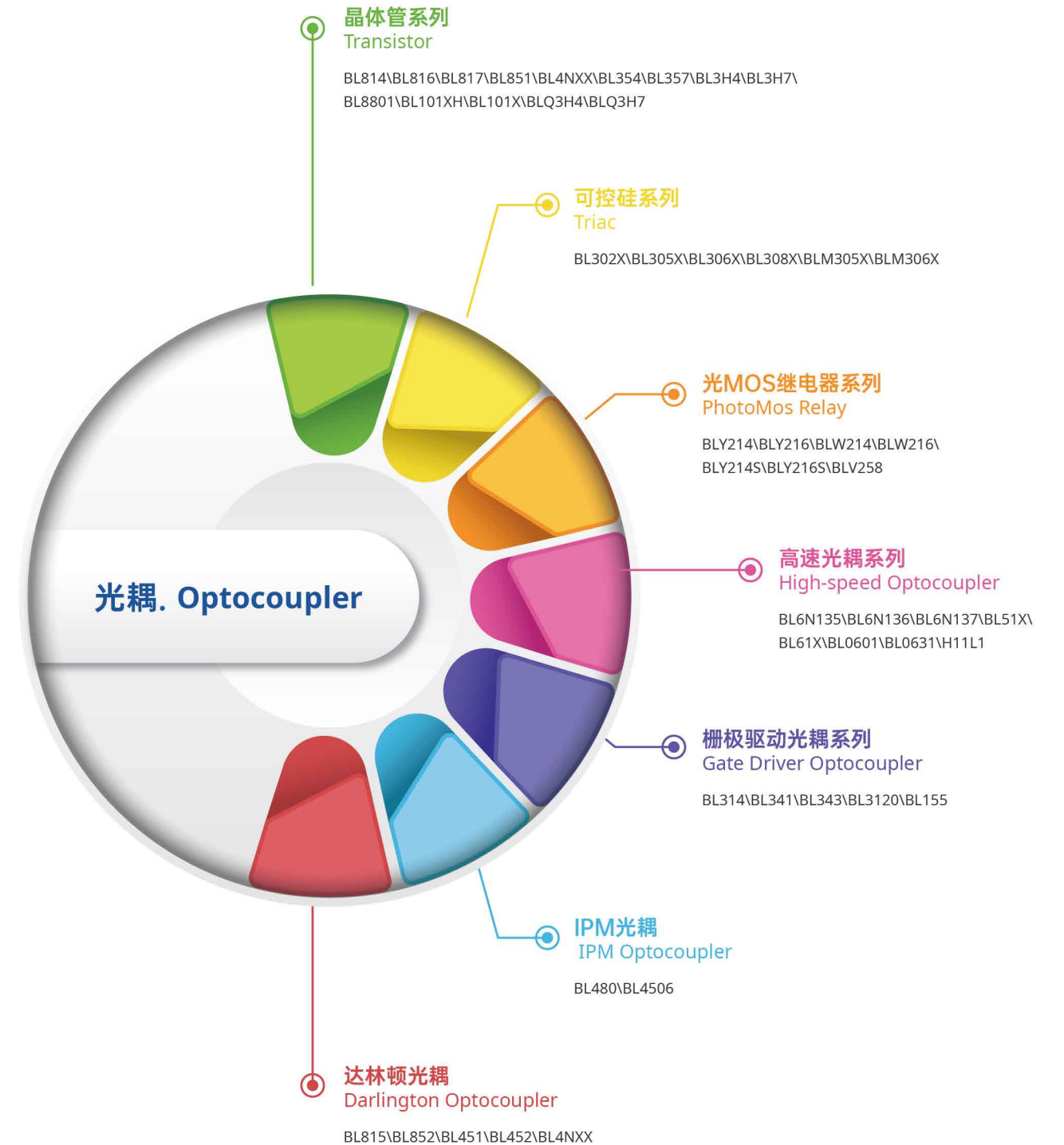
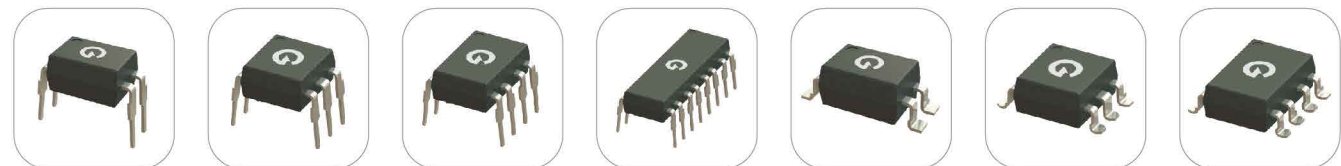

Test and Analysis 试验与分析

QMS 质量管理体系



可靠性试验参考标准: AEC-Q101-E版

分组	序号	项目缩写	项目名称
A 加速环境应力测试	1	PC	预处理
	2	HAST	高加速寿命试验
	2 alt	H3TRB	高温高湿反偏
	3	IOL	间歇寿命
	4	AC	高压蒸煮
	4 alt	UHAIST	无偏置高加速寿命
B 加速寿命测试	5	TC	温度循环
	5 a	TCHT	温度循环后热测试
	5 b	TCDT	温度循环后DPA分析
	6	HTRB	高温反偏
	7	HTGB	高温栅偏
	8	SSOP	稳态寿命
C 封装组件完整性测试	9	DPA	破坏性物理分析
	10	PD	尺寸测量
	11	WBP	焊线强度
	12	WBS	推球强度
	13	DS	推晶强度
	14	TS	端子强度
	15	RTS	印字牢度
	16	RSH	耐焊接热
	17	TR	热阻
	18	SD	可焊性
19	WG	锡须	
D 芯片制造工艺可靠性测试	20	DI	介电强度
E 电气验证测试	21	EV	外观检查
	22	TEST	电性测试
	23	PV	三温测试
	24	ESDH	静电HBM
	25	ESDC	静电CDM
	26	UIS	非钳位电感开关

FA分析流程 FA Analysis Process



制程&产品品质保证 Process & Product Quality Assurance

工程&生产&品质三部门共同负责:

- ◎ 设计开发生产工艺过程
- ◎ 管控生产过程
- ◎ 实时自我评估和改善

Engineering, Production, and Quality Departments work together to:

- ◎ Design and Develop Production Processes.
- ◎ Control the Production Process.
- ◎ Real-time Self-assessment and Improvement.

品质保证系统 Quality Assurance System
 品质管控系统 Quality Control System

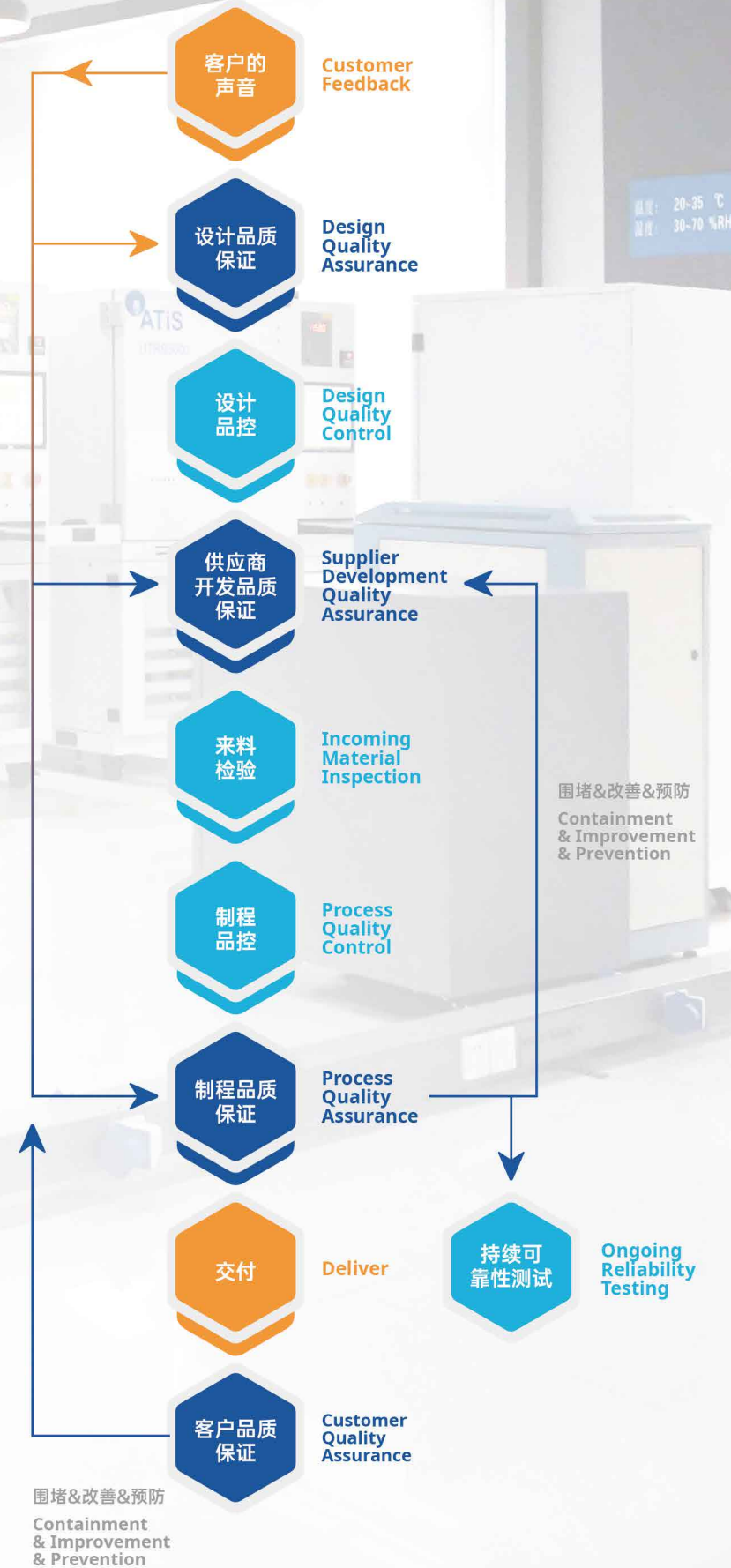

Sustainability 可持续发展



公司秉承低碳经营的可持续发展理念，致力于实现人与自然的和谐共存。积极推行ISO50001、ISO14064、ISO14067、清洁生产等标准体系，倡导绿色经营，通过导入太阳能光伏电站、无纸化智能办公系统、废水回收利用系统、余热回收利用系统、高密度矩阵式框架生产技术等管理改进和技术革新方案，努力减少有毒有害物质排放，降低工业废弃物产生，提高清洁能源使用占比，提升资源使用效率，以实现可持续发展的战略目标。

The company adheres to the sustainable development concept of low-carbon operation and is committed to realizing the harmonious coexistence of man and nature. We actively implement ISO50001, ISO14064, ISO14067, clean production and other standard systems, advocate green management, and through the introduction of solar photovoltaic power plant, paperless intelligent office system, wastewater recycling and utilization system, waste heat recycling and utilization system, and high-density matrix frame production technology, and other management improvement and technological innovation programs. We strive to reduce the emission of toxic and hazardous substances, reduce the generation of industrial waste, increase the proportion of clean energy use, and enhance the efficiency of resource use in order to realize the strategic goal of sustainable development.

Green Manufacturing & Low Carbon Management

绿色制造 & 低碳经营



可循环用水 Recyclable Water

处理能力：500吨/天，产水率：50%
Processing Capacity: 500 tons/day, Water yield: 50%

将公司制纯水系统产生的水质较好浓水和冲洗水、空调系统冷凝水/冷却塔系统排水、生产制造过程中的污染物较少的工艺废水（浸锡车间的冲洗废水、芯片车间的冲洗废水）进行回收，通过药剂混凝、过滤、反渗透等工艺去除杂质，提升水质，回用至制纯水系统的原水箱和一级RO水箱，从而实现节约用水的目标。

The concentrated water and rinse water of good quality generated by the company's pure water system, condensate from the air conditioning system/cooling tower system discharge water, and process wastewater with fewer pollutants in the production and manufacturing process (rinse wastewater from the plating workshop, and rinse wastewater from the wafer workshop) are recycled. Through pharmaceutical coagulation, filtration, reverse osmosis and other processes to remove impurities, improve the water quality, reuse to the original water tank of the pure water system and the first-class RO tank, so as to achieve the goal of water conservation.



社会责任 Social Responsibility

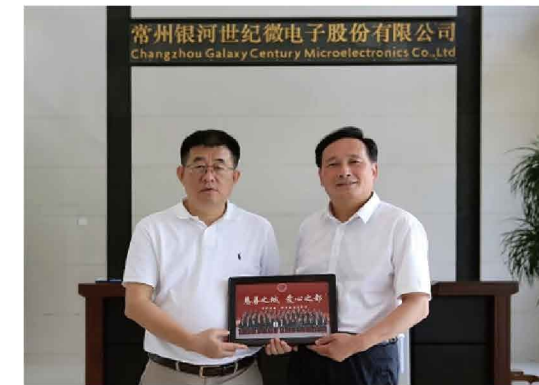

公司获“慈善之星”荣誉
The Honor of "Charity Star"



公益活动, Benefit Activities



关爱员工子女公益活动
Public Welfare Activities: Caring for Employees' Children



无偿献血, Blood Donation

太阳能发电 Solar Power Generation

发电量：90万千瓦时/年
Power Generation: 900,000 KWH/year



太阳能光伏电站
Solar Photovoltaic Power Station



苏文电能智控系统
Intelligent Energy Control System