

Hardware specifications of VC pro Z Smart Cameras

Revision: 1.54

Date: 2023-09-07

Contact: support@vision-comp.com

Copyright: 1996-2023 Vision Components GmbH Ettlingen, Germany

Author: VC Support, <mailto:support@vision-comp.com>





Foreword and Disclaimer

This documentation has been prepared with most possible care. However Vision Components GmbH does not take any liability for possible errors. In the interest of progress, Vision Components GmbH reserves the right to perform technical changes without further notice.

Please notify support@vision-components.com if you become aware of any errors in this manual or if a certain topic requires more detailed documentation.

This manual is intended for information of Vision Component's customers only. Any publication of this document or parts thereof requires written permission by Vision Components GmbH.

Image symbols used in this document

Symbol	Meaning
	The Light bulb highlights hints and ideas that may be helpful for a development.
	This warning sign alerts of possible pitfalls to avoid. Please pay careful attention to sections marked with this sign.
	This is a sign for an example.

Trademarks

Linux, Debian, the Tux logo, Vivado, Xilinx and Zynq, ARM, Cortex, Windows XP, Total Commander, Tera Term, Motorola, HALCON, FreeRTOS, Vision Components are registered Trademarks. All trademarks are the property of their respective owners.

Table of Contents

- 1 General Information
 - 1.1 Technical Specification VC pro Z
- 2 Hardware Interfaces
 - 2.1 Power Connector J₀
 - 2.1.1 J₀ Pin Assignment
 - 2.1.2 Electrical Specification: Camera Power Supply
 - 2.1.3 Electrical Specification: Digital PLC I/O
 - 2.2 Option Connector J₁
 - 2.2.1 J₁ Pin Assignment
 - 2.2.2 Electrical Specification: Trigger I/O
 - 2.2.3 Electrical Specification: Encoder
 - 2.2.4 Electrical Specification: RS-232
 - 2.3 Ethernet Connector J_E
 - 2.3.1 J_E Pin Assignment
 - 2.4 Connectors J_{2A} and J_{2B}
 - 2.4.1 J_{2A} Pin Assignment
 - 2.4.2 J_{2B} Pin Assignment
 - 2.4.3 Available Ring Illuminator Options
 - 2.4.4 Electrical Specification: Flash LEDs
 - 2.5 Built-in heater
- 3 Software Interfaces
 - 3.1 GPIOs
 - 3.2 Trigger Assignment
 - 3.2.1 Output Trigger Signal Inversion
 - 3.3 Status LEDs
- 4 Accessories
 - 4.1 Camera order numbers
 - 4.2 Order numbers of all available VC pro Z Series Accessories
- 5 Appendix A: Block diagram VC pro Z Series
- 6 Appendix B: Dimensions VC pro Z Series

1 General Information

The **VC nano Z Series Smart Cameras** have been designed for high resolution image processing with a very small form factor. They are the ideal compromise between high performance and low system costs, and thus especially suited for high volume OEM applications. This makes them viable to use a smart camera in even more products than before.

Based on a dual-core processor ARM® Cortex®-A9 with 866 MHz and an integrated FPGA the models of the VC Z series offer solutions at extreme high-speed in real-time.

The operating system VC Linux provides for the ideal interaction of hard- and software.

All cameras are equipped with a battery backed real time clock and come with a range of inputs and outputs, with trigger input and flash trigger output, as well as an Ethernet interface.

The VC pro Z Hardware capabilities:

- built-in illumination connector
- two current outputs for LED light source
- encoder device support
- RS-232 interface

1.1 Technical Specification VC pro Z

Technical Data

Component / Feature	Specification
CMOS Sensor	VC pro Z 0010: 1/4" e2v EV76C541, monochrome or color (Bayer filter) version
	VC pro Z 0011: 1/1.8" e2v EV76C560, monochrome or color (Bayer filter) version
	VC pro Z 0015: 1/1.8" e2v EV76C570, monochrome or color (Bayer filter) version
	VC pro Z 0252: 1/1.8" Sony IMX252, monochrome or color (Bayer filter) version
	VC pro Z 0392: 1/2.3" Sony IMX392, monochrome or color (Bayer filter) version
	Active pixels
VC pro Z 0011: 1280(H) x 1024(V)	
VC pro Z 0015: 1600(H) x 1200(V)	
VC pro Z 0252: 2048(H) x 1536(V)	
VC pro Z 0392: 1920(H) x 1200(V)	
Pixel size	
	VC pro Z 0011: 5.3(H) x 5.3(V) μm
	VC pro Z 0015: 4.5(H) x 4.5(V) μm
	VC pro Z 0252: 3.45(H) x 3.45(V) μm
	VC pro Z 0392: 3.45(H) x 3.45(V) μm
	Active sensor size
VC pro Z 0011: 6.8(H) x 5.5(V) mm	
VC pro Z 0015: 7.2(H) x 5.4(V) mm	
VC pro Z 0252: 7.1(H) x 5.3(V) mm	
VC pro Z 0392: 6.6(H) x 4.1(V) mm	
High-speed shutter	
	VC pro Z 0252, 0392: 1 μs
Low-speed shutter	VC pro Z 0010, 0011, 0015: up to 1 sec. adjustable integration time

Component / Feature	Specification
	VC pro Z 0252, 0392: up to 2 sec. adjustable integration time
Integration	Global shutter
Picture taking	program-controlled or external high speed trigger, jitterfree acquisition VC pro Z 0010: full-frame 134 frames per second VC pro Z 0011: full-frame 63 frames per second VC pro Z 0015: full-frame 55 frames per second VC pro Z 0252: full-frame 88 frames per second VC pro Z 0392: full-frame 118 frames per second
A/D conversion	118.75 MHz / 10 bit, only the 8 most significant bits used
Input LUT	no
Image Display	Via Ethernet onto PC
Processor	Dual-Core ARM® Cortex®-A9 with 866MHz and integrated FPGA
RAM	512 MB DDR-SDRAM
Flash EPROM	16 GB flash memory (nonvolatile) industrial eMMC
Process interface	4 inputs / 4 outputs, outputs 400 mA each (limited to 1A in total)
Flash Outputs	4 flash outputs with programmable current: 2 internal / 2 external. External outputs are configurable as additional PLC outputs.
Encoder Inputs	Optional, but encoder inputs can be used as additional 5V inputs.
Trigger Input	1 dedicated picture trigger input. Any of the available PLC or 5V inputs can be chosen as an optional trigger input source.
Trigger Output	1 default trigger output on FLASH ₀ /TrigOut pin. Any set of the available PLC or FLASH outputs (internal or external) can be chosen as trigger output.
Ethernet interface	1 Gbit / 100 Mbit / 10 Mbit
Serial interface	RS-232
CE certification	CE Certification from Vision Components
Storage Conditions	Temperature -20 to +60 deg C, Max. humidity: 90%, non condensing.
Operating Conditions	<ul style="list-style-type: none"> without heater: Temperature: 0 to +50 deg C, Max. humidity: 80%, non condensing. with heater: Temperature: -20 to +50 deg C, Max. humidity: 80%, non condensing.
Power Supply	24V DC <ul style="list-style-type: none"> without PLC illumination: max. 200 mA with maximum PLC output current (limited to 1A in total) and maximum illumination current, or power-up with heater activated: max. 1500 mA
Power Consumption	2.9 W typical
Heater	23 W (only in cameras with S/N 4000673 and higher)

The following diagram shows the **maximum** reachable (with the shortest shutter time) framerate according to the number of captured lines for the **VC pro Z 0010**, the **VC pro Z 0011**, the **VC pro Z 0015** and the **VC pro Z 0252**:

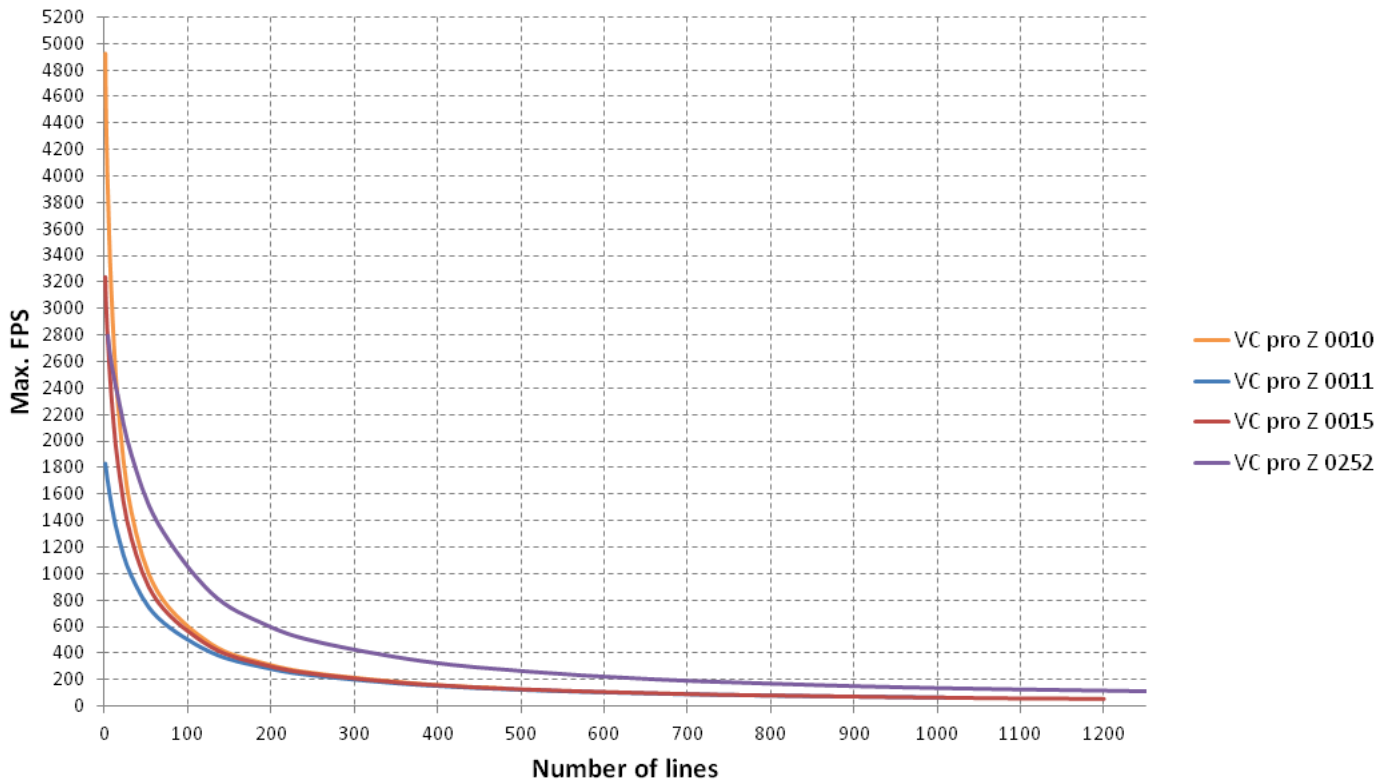

Frames per second over number of lines

The following table gives some example values.

Example Framerates

VC pro Z 0010		VC pro Z 0011		VC pro Z 0015		VC pro Z 0252	
Resolution	Max. framerate (FPS)	Resolution	Max. framerate (FPS)	Resolution	Max. framerate (FPS)	Resolution	Max. framerate (FPS)
				1600 x 1200	55	2048 x 1536	88
		1280 x 1024	63	1600 x 1024	63	2048 x 1024	134
		1280 x 768	83	1600 x 768	84	2048 x 768	177
		1280 x 640	98	1600 x 640	101	2048 x 640	210
736 x 480	134	1280 x 512	121	1600 x 512	125	2048 x 512	260
736 x 384	167	1280 x 384	158	1600 x 384	164	2048 x 384	338
736 x 256	246	1280 x 256	228	1600 x 256	240	2048 x 256	485
736 x 192	323	1280 x 192	292	1600 x 192	312	2048 x 192	619
736 x 128	470	1280 x 128	406	1600 x 128	447	2048 x 128	856
736 x 64	861	1280 x 64	669	1600 x 64	788	2048 x 64	1382
736 x 32	1473	1280 x 32	986	1600 x 32	1272	2048 x 32	1903
736 x 16	2288	1280 x 16	1295	1600 x 16	1836	2048 x 16	2340
736 x 8	3158	1280 x 8	1535	1600 x 8	2359	2048 x 8	2598
736 x 4	3901	1280 x 4	1691	1600 x 4	2765	2048 x 4	2797
736 x 2	4422	1280 x 2	1783	1600 x 2	3015	2048 x 2	N/A
736 x 1	4925	1280 x 1	1832	1600 x 1	3238	2048 x 1	N/A

Note



The measurements were done without any other CPU load. Parallel image processing tasks may lead to a lower framerate. These values are only reachable by limiting the maximum image acquisition size at capture initialisation, as explained on this page: [Image Acquisition \(scroll down to "Changing the Sensor ROI"\)](#).

2 Hardware Interfaces

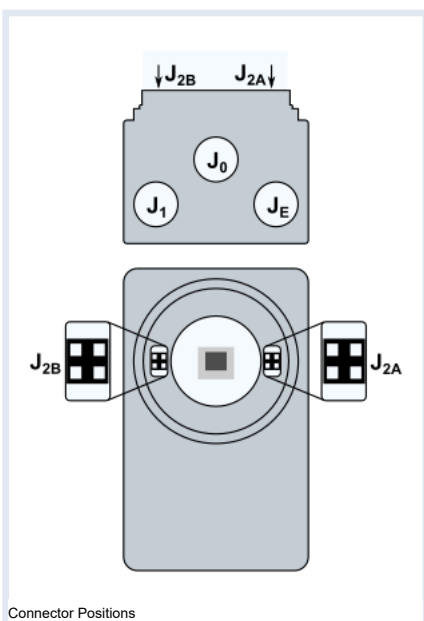

The VC pro Z camera incorporates the following connector interfaces:

Nomenclature for Connectors

Connector	Description
J ₀	Power Connector
J ₁	Option Connector
J _{2A}	Internal Illumination Source Connector
J _{2B}	Reserved
J _E	Ethernet Connector

2.1 Power Connector J₀

2.1.1 J₀ Pin Assignment

Pin Assignment of J₀ Connector (M12 A-Coding Binder 09-3491-600-12 - male)

Camera Socket Rear View	Pin	Signal	Level	Cable Standard Color
	1	Main Power Supply	+24 V	brown
	2	Common Ground	GND	blue
	3	PLC _{In0}	+24 V	white
	4	PLC _{Out0}	+24 V	green
	5	PLC _{In1}	+24 V	pink
	6	PLC _{Out1}	+24 V	yellow
	7	PLC _{Out2}	+24 V	black
	8	PLC _{In2}	+24 V	grey
	9	PLC _{Out3}	+24 V	red
	10	PLC _{In3}	+24 V	purple
	11	FLASH ₀ /TrigOut	+24 V	grey/pink
	12	FLASH ₁	+24 V	red/blue

Warning



Ensure, that the current is always limited in such a way that it cannot destroy the to the FLASH₀ and FLASH₁ pin connected hardware.

Note



For a detailed description of the TrigOut connector see section [Electrical Specification: Trigger I/O](#).
For a detailed description of the FLASH₀ and FLASH₁ connector see section [Electrical Specification: Flash LEDs](#).

2.1.2 Electrical Specification: Camera Power Supply

Voltage/Current Overview

What	How much
Nominal Voltage	+24 V
Absolute Voltage Limits	+32V
Minimum nominal Operating voltage	21.6V
Maximum nominal Operating voltage	26.4V
Operating Current (Typical)	120mA (see note)
Operating Current (Maximum)	200mA (see note)
Nominal Power Consumption (Typical)	2.9W (see note)
Nominal Power Consumption (Maximum)	5W (see note)

Note



The power consumption relies on a setup without internal or external LED illumination and without PLC I/O current.

2.1.3 Electrical Specification: Digital PLC I/O

Electrical Specifications

Separation of PLC/trigger output voltage	PLC outputs supply not separated from power supply
PLC Input Voltage	24V, threshold: 12V
Input Current (max)	1.5mA @ 24V
PLC Output Voltage	24V
PLC Output Current (max)	4 x 400 mA Max total of all outputs: 1A
Max Current for 1 Power / PLC connector pin	400 mA
Power failure detection	Yes, power failure detected if total PLC current > 1A

Warning



If power failure is detected, all PLC outputs may switch off regardless of their output state.

2.1.3.1 Connection of PLC inputs VC pro Z Series

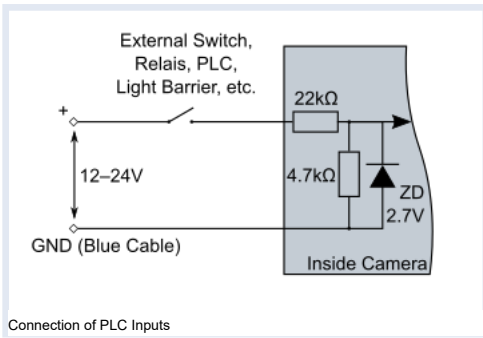

2.1.3.2 Connection of PLC outputs VC pro Z Series

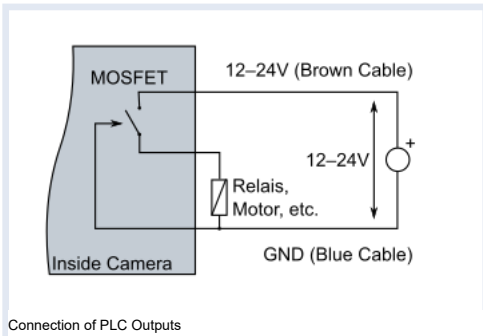

2.2 Option Connector J₁

It is not necessary for that socket to be connected for image acquisition.

2.2.1 J₁ Pin Assignment

Pin Assignment of J₁ Connector (M12 A-Coding Binder 09-3492-600-12 - female)

Camera Socket Rear View	Pin	Signal	Level	Cable Standard Color
	1	P5V_Out max 100mA, switched	5V	brown
	2	GND	GND	blue
	3	V24_TxD	±12V max. [1]	white
	4	TrigIn_P	5V	green
	5	TrigIn_M	GND	pink
	6	ENC /Z	5V	yellow
	7	ENC Z	5V	black
	8	ENC B	5V	grey
	9	ENC /A	5V	red
	10	ENC A	5V	purple
	11	V24_RxD	±12V max.	grey/pink
	12	ENC /B	5V	red/blue

[1] Standard RS-232 voltage. Refer to the RS-232 specification for exact voltage and tolerance.

2.2.2 Electrical Specification: Trigger I/O

The TrigOut connector is available over the Power Connector J₀!

Electrical Specifications

Separation of trigger input	Yes, optically isolated, 8mA @ 5V
Separation of trigger output	No
Trigger output voltage	Identical with power supply voltage
Trigger output current (max)	400 mA (1500 mA pulse)

Note



For a connection example for the TrigOut, see [Connection of Flash Outputs: External Flash](#), [Connection of Flash Outputs: Direct High-Power-LEDs](#), [Connection of Flash Outputs: PLC](#)

2.2.2.1 Connection of Trigger Input

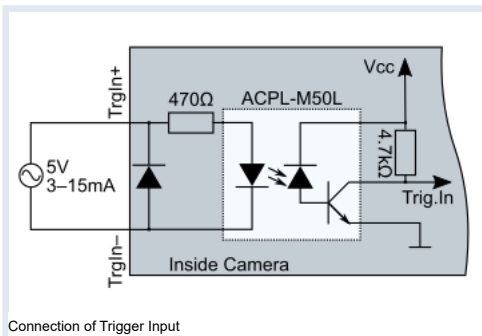

2.2.3 Electrical Specification: Encoder

Optional.

Electrical Specifications

Separation of Encoder Signals	No
Encoder Input Voltage	5V, differential

Note



You can optionally use the encoder pins as 5V inputs.

2.2.3.1 Connection of Encoder inputs VC pro Z Series

Optional.

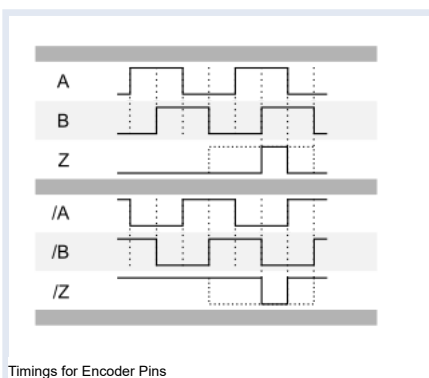

2.2.4 Electrical Specification: RS-232

Standard Voltage vor RS-232 (V.24).

2.3 Ethernet Connector J_E

2.3.1 J_E Pin Assignment

Pin Assignment of J_E Connector (M12 X-Coding Binder 09-3782-91-08 - female)

Camera Socket Rear View	Pin	Signal
	1	ETH_A_p
	2	ETH_A_n
	3	ETH_B_p
	4	ETH_B_n
	5	ETH_D_p
	6	ETH_D_n
	7	ETH_C_n
	8	ETH_C_p

2.4 Connectors J_{2A} and J_{2B}

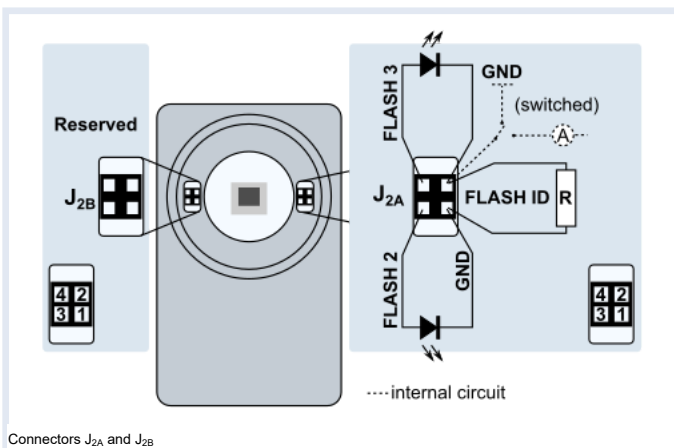

Note



Activation of flash output is done by assigning the right GPIO via the command line tool named `vcio` (and `vcproz_flash_set`), see [GPIOs](#) and [Trigger Assignment](#) for more information.

2.4.1 J_{2A} Pin Assignment

Pin Assignment of J_{2A} Connector

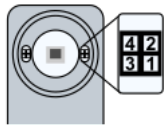
Camera Socket Top View	Pin	Signal
	1	GND
	2	GND switched, REF
	3	FLASH ₂
	4	FLASH ₃

LEDs at the connector J_{2A} must have an extra resistor attached whose resistance value encodes the allowed flash duration at specific current values. If the current value is set to 0.0 A, the circuit however provides the pins with a minimum current due to buffering purposes.

Warning



Ensure, that the current is always limited in such a way that it cannot destroy the to the FLASH₂ and FLASH₃ pin connected hardware.

Warning



Never dis-/connect something to the J_{2A} or J_{2B} connector without turning off the camera device.

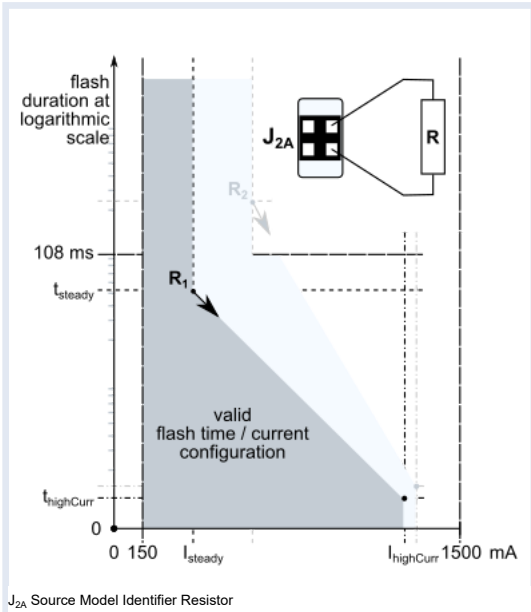

The formula used to calculate the current between maximum steady current and maximum flash current is based on durations at currents specified by the resistor ID of the LED ring, see the table named 'J_{2A} Connector Resistor Specification':

$$t_{set} = t_{steady} * (\exp^{-(I_{request} - I_{steady}) / (I_{steady} * \ln(t_{steady})) - \ln(I_{highCurr})}) / (I_{highCurr} - I_{steady})$$

2.4.2 J_{2B} Pin Assignment

Left blank for future use. Do not connect!

2.4.3 Available Ring Illuminator Options

Ring Illuminators

General Information			Maximum Flash Current			Maximum Steady Current	
Spectrum	LED Count	Opening angle	Resistor [Ω]	I _{highCurr} [mA]	t _{highCurr} [s]	I _{steady} [mA]	t _{steady} [s]
IR 850nm	× 32	±10°deg	220R	1500	1.0e-4	300	1.0e-2
White	× 12	±40°deg	2200R	1000	1.0e-3	500	1.0e-1
IR 850nm	× 12	±45°deg	2700R	1500	15.0e-3	500	1.0e-1

This specification is subject to change for the limiting values due to technical improvements without further notice. For this reason please try to avoid programming current values higher than reported as maximum by the program *vcproz_flash_set*.

2.4.3.1 Mounting The Ring Illuminator

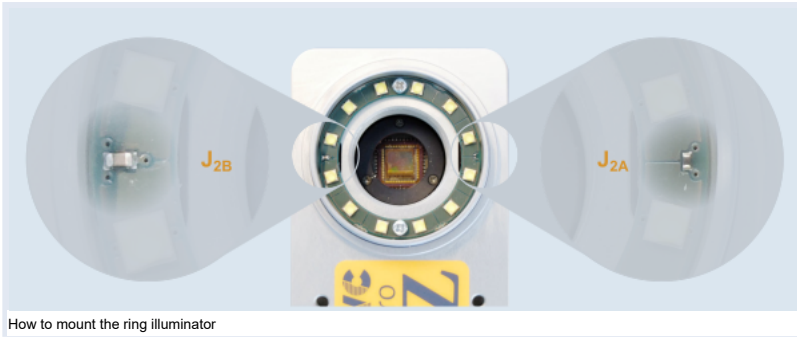

Make sure to mount the ring illuminator as depicted at the figure 'How to mount the ring illuminator' so that the smaller vertical resistor is to the right, and the larger horizontal resistor is to the left. Also make sure to place all four pins of both connectors J_{2A} and J_{2B} properly, and to align the mounting holes with the corresponding threads. It may be necessary to apply a heat spreading pad between the camera and the illuminator ring. The illuminator ring must be fixed mechanically with two screws of type M2x4.

2.4.4 Electrical Specification: Flash LEDs

Note



Activation of flash output is done by assigning the right GPIO via the command line tool named `vcio` (and `vcproz_flash_set`), see [GPIOs](#) and [Trigger Assignment](#) for more information.

The FLASH₀ and FLASH₁ outputs are available over the Power Connector J₀.

The VC pro Z Hardware features four independently adjustable current sources for the connection of four LED light sources. Two of the current sources are designed for controlling the ring illuminators around the lens, connected to J_{2A}. The other two current sources are accessible over the connector J₀.

The default and system startup current at the FLASH₀, FLASH₁, FLASH₂ and FLASH₃ pins are 500 mA, limited to 1ms duration.

The controller covers a current range from 150 to 1500 mA. The controller provides a *steady current* in the range from 150 to 400 mA. Currents over 400 mA are available in *flash mode* saving LED lifetime.

The duty cycle is limited to 1:8, i.e. the off-state is eight times longer than the on-state for the output. Example: 1 ms flash duration, 8 ms cool down duration.

The flash duration depends on the real flash duration and not the maximum given flash duration.

Technical Data for each LED Controller

I _{out}	150-1500 mA, programmable
U _{out}	4-16 V (1-4 LEDs depending on the V _f)
I _{steady}	< 400 mA
I _{highCurr}	400-1500 mA
t _{pulse}	> 20 μs

In the header file `vcproz.h` are the ranges available as defines.

Defines in Header File `vcproz.h`

Define Name	Meaning
VCPROZ_FLASH_MAXCURR_MA	Maximum current configurable for flash output pins.
VCPROZ_FLASH_MINCURR_MA	Minimum current configurable for flash output pins (0mA will be set if request is lower).
VCPROZ_FLASH01_MAXCURRSDY_MA	For FLASH 0 and FLASH 1 output pins, current above this level will limit the flash duration to @ref VCPROZ_FLASH01_DURTNLIMIT_US.
VCPROZ_FLASH01_DURTNLIMIT_US	Maximum Duration in microseconds

2.4.4.1 Connection of Flash Outputs: External Flash

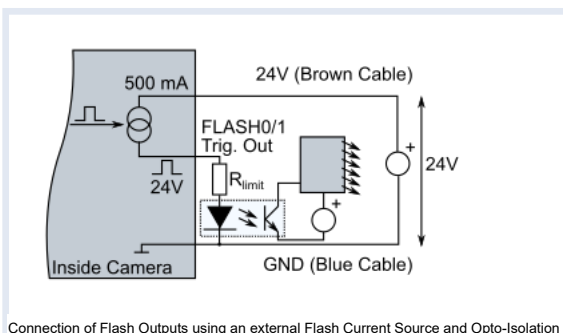

Connection of Flash Outputs using an external Flash Current Source and Opto-Isolation

The figure shows how to connect an external flash illumination to FLASH₀/TrigOut signal by using an opto isolation. R_{limit} should be chosen to protect the opto isolator, e.g. 2K2/250mW for a current of 10mA. Remark: R_{limit} is not necessary for Vision Components' High Power IR Illumination VK XXXXXXXX. The current source should be set to 500 mA.

2.4.4.2 Connection of Flash Outputs: Direct High-Power-LEDs

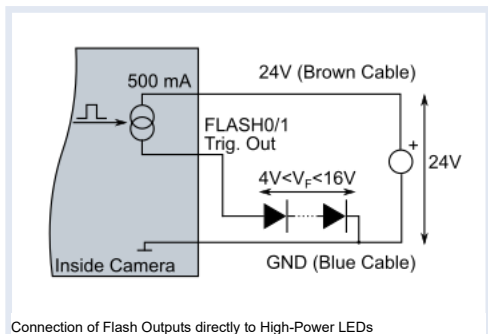

The figure shows how to connect an external flash illumination. The current source should be set to the required current setting between 200 and 1500 mA. The time limit must be set to an appropriate value for the protection of the external LEDs according to the data sheet of the manufacturer. Connectable are 1 to 6 High Power LEDs.

2.4.4.3 Connection of Flash Outputs: PLC

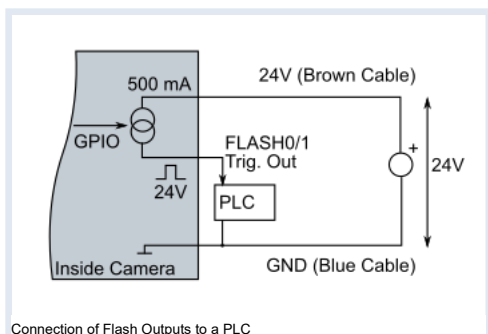

The figure shows how to connect a PLC to the FLASH₀/TrigOut or FLASH₁ signal. The current source should be set to 500 mA.

Warning



Do not connect inductive loads to FLASH₀ or FLASH₁ outputs!

2.5 Built-in heater

The VC pro Z camera contains a built-in heater which is automatically activated when necessary. The following table and diagram show the behaviour of the heater. The heater is integrated in all VC pro Z cameras starting from S/N 4000673.

Heater

Temperature	Heating power	CPU
T < -5 °C	100 % (23 W)	Off
-5 °C < T < 5 °C	20 % (4.6 W)	On
T > 5 °C	0 %	On

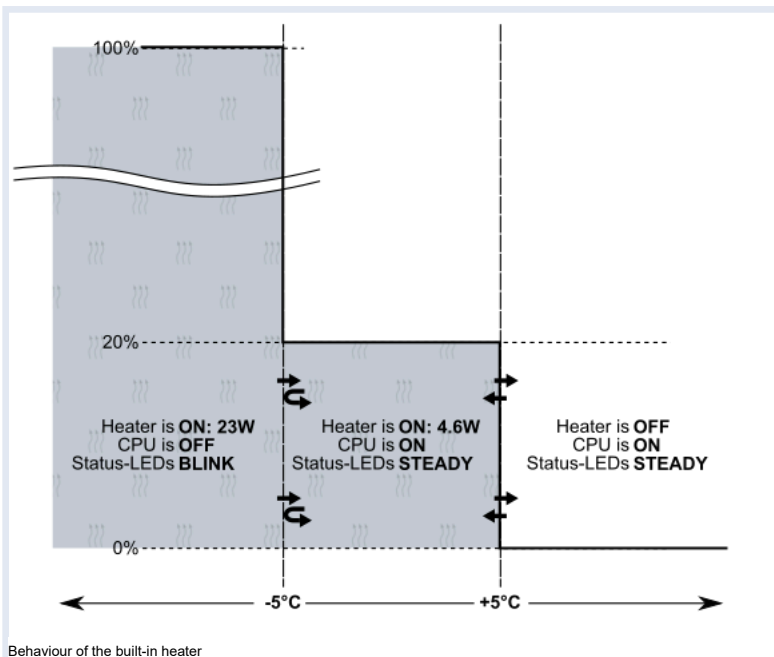

3 Software Interfaces

3.1 GPIOs

Connector Assignment of GPIOs

GPIO Nr.	Connector	Pin Designator	Usability	Remark
0	J ₀	OUT 0	Output	—
1	J ₀	OUT 1	Output	—
2	J ₀	OUT 2	Output	—
3	J ₀	OUT 3	Output	—
4	—	—	—	—
5	—	—	—	—
6	—	—	—	—
7	—	—	—	—
8	—	—	—	—
9	—	—	—	—
10	J ₀	INP 0	Input	—
11	J ₀	INP 1	Input	—
12	J ₀	INP 2	Input	—
13	J ₀	INP 3	Input	—
14	J ₁	ENC N	Input	Signal cannot be used as input if encoder active
15	J ₁	ENC A	Input	Signal cannot be used as input if encoder active
16	J ₁	ENC B	Input	Signal cannot be used as input if encoder active
17	—	—	—	—
18	J ₀	FLASH ₁	Output	Adjustable current source
19	J _{2A}	FLASH ₂	Output	Adjustable current source
20	J _{2A}	FLASH ₃	Output	Adjustable current source
21	—	—	—	—
22	—	—	—	—
23	—	—	—	—
24	—	—	—	—
25	—	—	—	—
26	—	—	—	—
27	—	—	—	—
28	—	—	—	—
29	INTERNAL	MALFUNCTION	Input	—
30	—	—	—	—
31(Out)	J ₀	FLASH ₀ /TrigOut	Output	Adjustable current source
31(In)	J ₁	TrigIn	Input	Optically isolated

4 Accessories

4.1 Camera order numbers

VC pro Z Cameras

Order Number	Product / Service description
VK002859	VC pro Z 0010 Smart Camera, b/w sensor
VK002858	VC pro Z 0010 Smart Camera, bayer sensor
VK002088	VC pro Z 0011 Smart Camera, b/w sensor
VK002257	VC pro Z 0011 Smart Camera, bayer sensor
VK002207	VC pro Z 0015 Smart Camera, b/w sensor
VK002230	VC pro Z 0015 Smart Camera, bayer sensor
VK003148	VC pro Z 0252 Smart Camera, b/w sensor
VK003133	VC pro Z 0252 Smart Camera, bayer sensor
VK003161	VC pro Z 0392 Smart Camera, b/w sensor
VK002147	VC pro Z 0011 Carrida Cam Smart Camera, b/w sensor

4.2 Order numbers of all available VC pro Z Series Accessories

VC pro Z Accessories

Order Number	Product / Service description
VK002154	VC pro Z Lens Tube 15 mm
VK002155	VC pro Z Lens Tube 35 mm
VK002157	VC pro Z Lens Tube 35 mm with light guide
VK002156	VC pro Z Lens Tube 45 mm
VK002158	VC pro Z Lens Tube 45 mm with light guide
VK002228	VC pro Z Lens Tube 55 mm
VK002212	VC pro Z LED Ring Light - red 640 nm
VK002213	VC pro Z LED Ring Light - IR 850 nm
VK002233	VC pro Z LED Ring Light - UV
VK002876	VC pro Z LED Ring Light - White
VK002227	VC pro Z Protection cap for unused connector

If you plan to use the pro Z camera outdoors, we advise you to order protection caps for all unused connectors, so that the IP67 property is ensured.



5 Appendix A: Block diagram VC pro Z Series

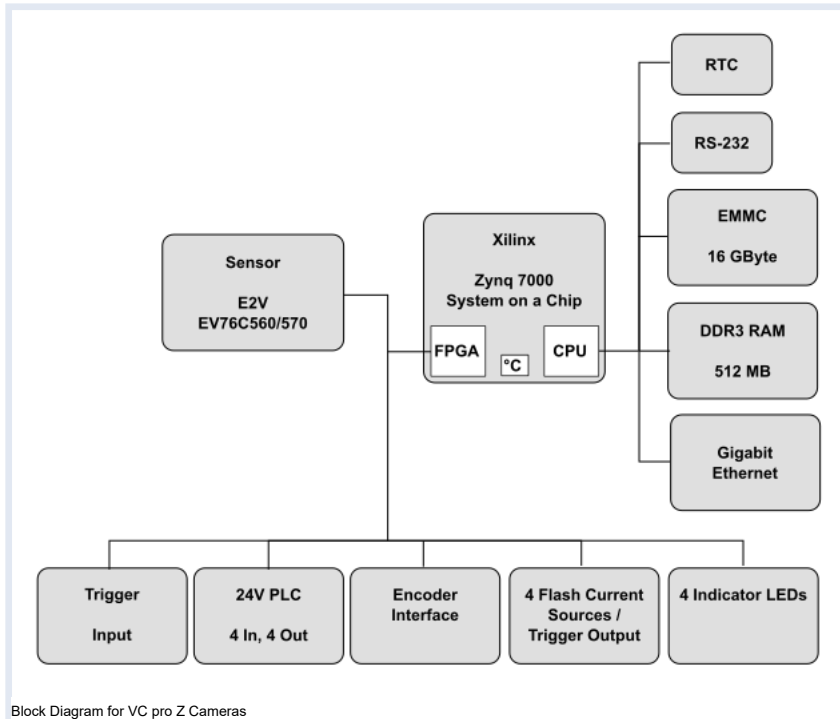

Block Diagram for VC pro Z Cameras

6 Appendix B: Dimensions VC pro Z Series

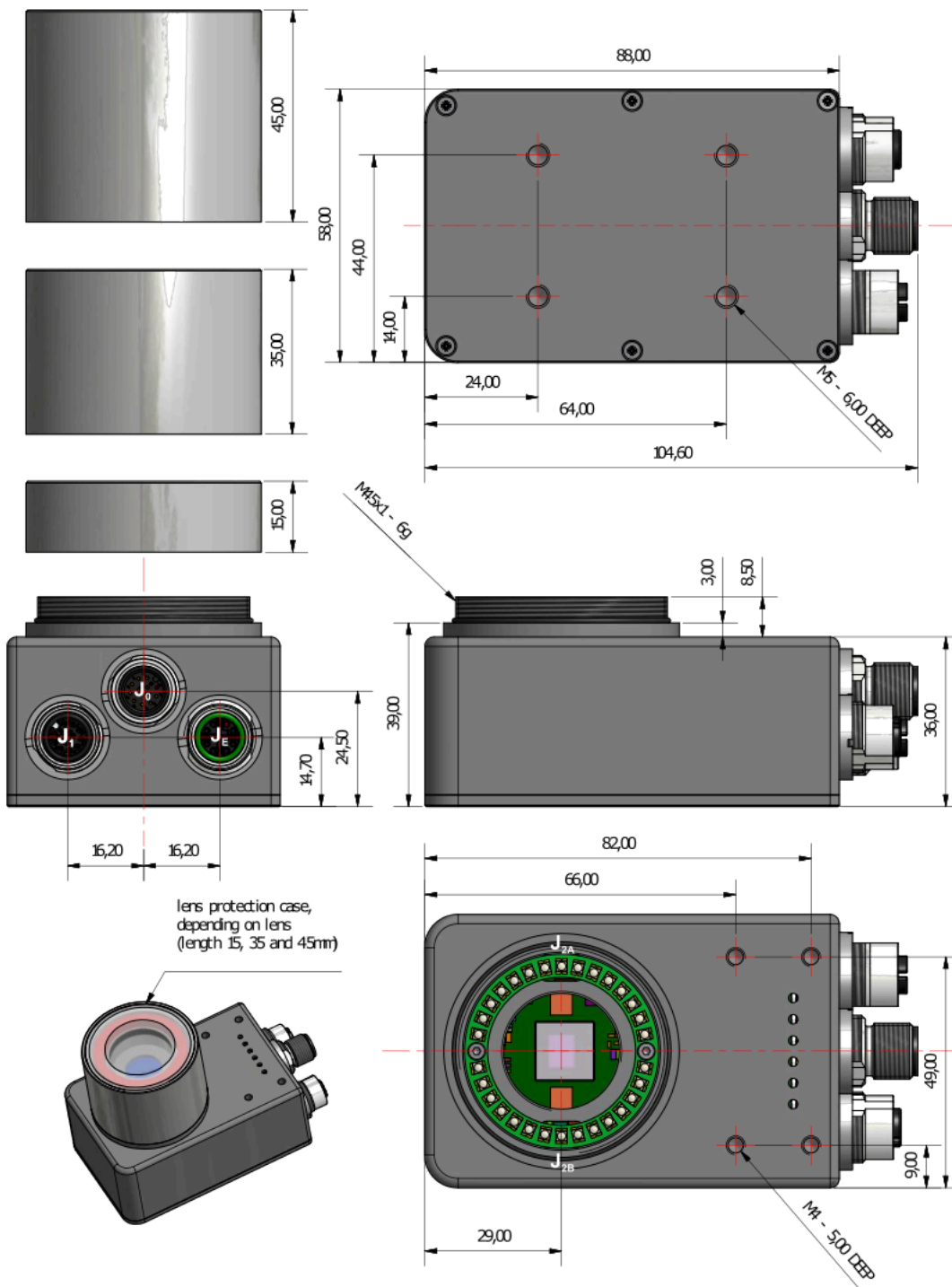

Dimensions of various parts of the VC pro Z Series Camera