

Hardware specifications of VC nano Z Smart Cameras

Revision: 2.0.2

Date: 2023-09-07

Contact: support@vision-comp.com

Copyright: 1996-2023 Vision Components GmbH Ettlingen, Germany

Author: VC Support, <mailto:support@vision-comp.com>





Foreword and Disclaimer

This documentation has been prepared with most possible care. However Vision Components GmbH does not take any liability for possible errors. In the interest of progress, Vision Components GmbH reserves the right to perform technical changes without further notice.

Please notify support@vision-components.com if you become aware of any errors in this manual or if a certain topic requires more detailed documentation.

This manual is intended for information of Vision Component's customers only. Any publication of this document or parts thereof requires written permission by Vision Components GmbH.

Image symbols used in this document

Symbol	Meaning
	The Light bulb highlights hints and ideas that may be helpful for a development.
	This warning sign alerts of possible pitfalls to avoid. Please pay careful attention to sections marked with this sign.
	This is a sign for an example.

Trademarks

Linux, Debian, the Tux logo, Vivado, Xilinx and Zynq, ARM, Cortex, Windows XP, Total Commander, Tera Term, Motorola, HALCON, FreeRTOS, Vision Components are registered Trademarks. All trademarks are the property of their respective owners.

Table of Contents

- 1 General Information**
- 2 Technical Specifications**
 - 2.1 Technical Specifications VC nano Z**
- 3 Camera Interfaces**
 - 3.1 LAN / Ethernet Interface**
 - 3.2 Power Supply, I/O interface and trigger interface**
 - 3.3 VC nano Z Series LED**
- 4 Software Interfaces**
 - 4.1 GPIOs**
 - 4.2 Trigger Assignment**
- 5 Accessories**
 - 5.1 Camera order numbers**
 - 5.2 Order numbers of all available VC nano Z Series Accessories**
- 6 Appendix A: Block diagram VC nano Z Series**
- 7 Appendix B: Dimensions VC nano Z Series**

1 General Information

The **VC nano Z Series Smart Cameras** have been designed for high resolution image processing with a very small form factor. They are the ideal compromise between high performance and low system costs, and thus especially suited for high volume OEM applications. This makes them viable to use a smart camera in even more products than before.

Based on a dual-core processor ARM® Cortex®-A9 with 866 MHz and an integrated FPGA the models of the new VC Z series offer solutions at extreme high-speed in real-time.

The operating system VC Linux provides for the ideal interaction of hard- and software.

All cameras are equipped with a battery backed real time clock and come with 2 inputs and 4 outputs, with trigger input and flash trigger output, as well as an Ethernet interface. 5 different CMOS sensors (the image resolution can be changed to the ROI required) with global shutter and a resolution up to 4.2 Megapixel are available with all models.

The extremely low power consumption of only 1.7W makes this camera ideally suitable for use in mobile devices.

2 Technical Specifications

2.1 Technical Specifications VC nano Z

Technical Data

Component / Feature	Specification
CMOS Sensor	VC nano Z 0010: 1/4" e2v EV76C541, monochrome version
	VC nano Z 0011: 1/1.8" e2v EV76C560, monochrome or color (Bayer filter) version
	VC nano Z 0015: 1/1.8" e2v EV76C570, monochrome or color (Bayer filter) version
	VC nano Z 0252: 1/1.8" Sony IMX252, monochrome or color (Bayer filter) version
	VC nano Z 0273: 1/2.9" Sony IMX273, monochrome or color (Bayer filter) version
	VC nano Z 0392: 1/2.3" Sony IMX392, monochrome or color (Bayer filter) version
	Active pixels
VC nano Z 0011: 1280(H) x 1024(V)	
VC nano Z 0015: 1600(H) x 1200(V)	
VC nano Z 0252: 2048(H) x 1536(V)	
VC nano Z 0273: 1440(H) x 1080(V)	
VC nano Z 0392: 1920(H) x 1200(V)	
Pixel size	
	VC nano Z 0011: 5.3(H) x 5.3(V) µm
	VC nano Z 0015: 4.5(H) x 4.5(V) µm
	VC nano Z 0252: 3.45(H) x 3.45(V) µm
	VC nano Z 0273: 3.45(H) x 3.45(V) µm
	VC nano Z 0392: 3.45(H) x 3.45(V) µm
	Active sensor size
VC nano Z 0011: 6.8(H) x 5.5(V) mm	
VC nano Z 0015: 7.2(H) x 5.4(V) mm	
VC nano Z 0252:	

Component / Feature	Specification
	7.1(H) x 5.3(V) mm VC nano Z 0273: 5.0(H) x 3.7(V) mm VC nano Z 0392: 6.6(H) x 4.1(V) mm
High-speed shutter	VC nano Z 0010, 0011, 0015: 15 μ s VC nano Z 0252, 0273, 0392: 1 μ s
Low-speed shutter	VC nano Z 0010, 0011, 0015: up to 1 sec. adjustable integration time VC nano Z 0252, 0273, 0392: up to 2 sec. adjustable integration time
Integration	Global shutter
Picture taking	program-controlled or external high speed trigger, jitterfree acquisition VC nano Z 0010: full-frame 134 frames per second VC nano Z 0011: full-frame 63 frames per second VC nano Z 0015: full-frame 55 frames per second VC nano Z 0252: full-frame 88 frames per second VC nano Z 0273: full-frame 181 frames per second VC nano Z 0392: full-frame 118 frames per second
A/D conversion	118.75 MHz / 10 bit, only the 8 most significant bits used for grey values
Input LUT	yes
Image Display	Via 100 Mbit Ethernet onto PC
Processor	Dual-Core ARM® Cortex®-A9 with 866MHz and integrated FPGA
RAM	512 MB DDR-SDRAM
Flash EPROM	16 GB flash memory (nonvolatile)
Process interface	2 inputs / 4 outputs, outputs 4x400 mA
Trigger	1 picture trigger input, 1 flash trigger output, 24V
Ethernet interface	100 Mbit
Serial interface	Not available
CE certification	CE Certification from Vision Components
Storage Conditions	Temperature: -20 to +60 deg C, Max. humidity: 90%, non condensing.
Operating Conditions	Temperature: 0 to +50 deg C, Max. humidity: 80%, non condensing.
Power Supply	12-24V DC, max. 300 mA
Power Consumption	approx. 2.4W

The following diagram shows the **maximum** reachable (with the shortest shutter time) framerate according to the number of captured lines for the **VC nano Z 0010**, the **VC nano Z 0011**, the **VC nano Z 0015**, the **VC nano Z 0252** and the **VC nano Z 0273**:

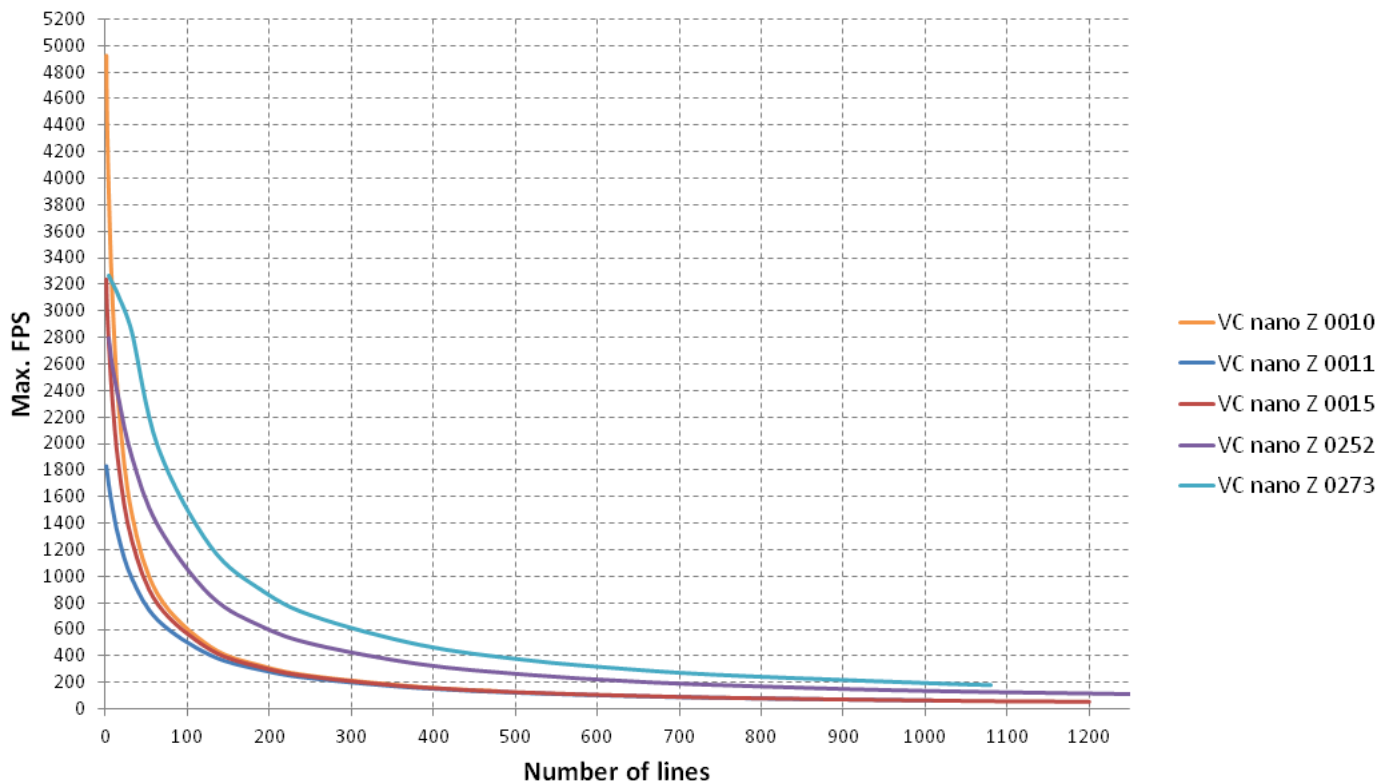

Frames per second over number of lines

The following table gives some example values.

Example Framerates

VC nano Z 0010		VC nano Z 0011		VC nano Z 0015		VC nano Z 0252		VC nano Z 0273	
Resolution	Max. framerate (FPS)	Resolution	Max. framerate (FPS)	Resolution	Max. framerate (FPS)	Resolution	Max. framerate (FPS)	Resolution	Max. framerate (FPS)
				1600 x 1200	55	2048 x 1536	88		
								1440 x 1080	181
		1280 x 1024	63	1600 x 1024	63	2048 x 1024	134	1440 x 1024	191
		1280 x 768	83	1600 x 768	84	2048 x 768	177	1440 x 768	252
736 x 480	134	1280 x 640	98	1600 x 640	101	2048 x 640	210	1440 x 640	300
736 x 384	167	1280 x 512	121	1600 x 512	125	2048 x 512	260	1440 x 512	370
736 x 384	167	1280 x 384	158	1600 x 384	164	2048 x 384	338	1440 x 384	483
736 x 256	246	1280 x 256	228	1600 x 256	240	2048 x 256	485	1440 x 256	695
736 x 192	323	1280 x 192	292	1600 x 192	312	2048 x 192	619	1440 x 192	890
736 x 128	470	1280 x 128	406	1600 x 128	447	2048 x 128	856	1440 x 128	1227
736 x 64	861	1280 x 64	669	1600 x 64	788	2048 x 64	1382	1440 x 64	1974
736 x 32	1473	1280 x 32	986	1600 x 32	1272	2048 x 32	1903	1440 x 32	2843
736 x 16	2288	1280 x 16	1295	1600 x 16	1836	2048 x 16	2340	1440 x 16	3112
736 x 8	3158	1280 x 8	1535	1600 x 8	2359	2048 x 8	2598	1440 x 8	3215
736 x 4	3901	1280 x 4	1691	1600 x 4	2765	2048 x 4	2797	1440 x 4	3267
736 x 2	4422	1280 x 2	1783	1600 x 2	3015	2048 x 2	N/A	1440 x 2	N/A
736 x 1	4925	1280 x 1	1832	1600 x 1	3238	2048 x 1	N/A	1440 x 1	N/A

Note



The measurements were done without any other CPU load. Parallel image processing tasks may lead to a lower framerate. These values are only reachable by limiting the maximum image acquisition size at capture initialisation, as explained on this page: [Image Acquisition \(scroll down to "Changing the Sensor ROI"\)](#).

3 Camera Interfaces



Connector Positions

The VC nano Z Series cameras incorporate the following connector interfaces:

- LAN / Ethernet interface
- PLC IO, power supply and trigger interface

The pin assignments, electrical specifications as well as available accessories are shown for each interface connector in the following sections.

3.1 LAN / Ethernet Interface

3.1.1 Pin Assignments LAN / Ethernet Interface

Ethernet Socket Pin Assignment

Camera Socket	Pin at Camera	Signal	20m Patch Cable Wire	10m Patch Cable Wire	Pin at PC
	2	Tx+	yellow	white/pink	1
	1	Tx-	orange	pink	2
	6	Rx+	white/green	white/green	3
	5	Rx-	green	green	6
	3	—	—	—	NC
	4	—	—	—	NC



The colors are for cables sold by us. Refer to the [Accessories](#) section for a list of available cables with order numbers.

3.2 Power Supply, I/O interface and trigger interface

This connector includes the camera Power Supply, the digital PLC IOs and the trigger interface.

3.2.1 Pin assignments Power Supply and IO Interface

Power Supply/IO Interface Pin Assignment

Camera Socket	Pin	Signal	Cable Colors
---------------	-----	--------	--------------

Camera Socket	Pin	Signal	Cable Colors
	1	12-24V PLC	red
	2	12-24V IN Cam	red / blue
	3	GND IN com.	black.
	4	INP 1	pink
	5	OUT 3	yellow
	6	OUT 2	green
	7	OUT 1	brown
	8	OUT 0	white
	9	12-24V PLC	grey / pink
	10	TrigOut	purple
	11	TrigIn	blue
	12	INP 0	grey

3.2.2 Electrical specifications Camera Power Supply

Warning



With the VC nano Z Series cameras the PLC supply contacts are internally connected with the camera power supply pin 2. In this case pin 1 and 9 require the same voltage level as the camera power supply pin 2. Refer to section 4.2.3 for details on the different PLC interface features.

Voltage/Current Overview

What	How much
Nominal Voltage	12 – 24 V
Absolute Voltage Limits	9 V - 30 V
Minimum nominal Operating voltage and corresponding current	12V, 160 mA
Maximum nominal Operating voltage and corresponding current	24V, 90 mA
Nominal Power Consumption	2.2W

In general the camera power supply is regulated in the camera, so an unregulated power source is sufficient. However the absolute voltage levels specified above should never be exceeded.

In case of unstable power supply (voltage spikes or power interruptions) it is recommended to back up the power supply by a capacitor or a battery large enough to prevent power interruptions.

It is recommended to switch on the low voltage supply (12 to 24V) when booting the camera. Some 110/ 220V power supplies increase the output voltage too slow or drop the voltage under load at startup which might cause the camera not to boot properly! A power supply able to supply a much higher than nominal boot current for a few milliseconds may be an alternative approach.

3.2.3 Electrical Specifications digital PLC IO / trigger Interface

Note



Activation of trigger output is done by assigning the right GPIO via the command line tool named `vcio`, see [GPIOs](#) and [Trigger Assignment](#) for more information.

The VC nano Z Series Smart Cameras feature digital inputs and outputs that allow e.g. direct input of light barriers signals or the control of pneumatic valves, as well as a trigger input and output.

Please observe the current and voltage ratings specified in the following sections.

Electrical Specifications

 Separation of PLC/trigger output voltage	PLC outputs supply not separated from power supply
PLC/trigger Input Voltage	Identical with power supply voltage
PLC/trigger Input Current (max)	1.0 mA at 12V to 2.0mA @ 24V
PLC/trigger Output Voltage	Identical with power supply Voltage — internally connected
PLC/trigger Output Current (max)	4 x 400 mA Max total of all outputs: 1A
Max Current for 1 Power / PLC connector pin	500 mA
Power failure detection	—

Warning



When using the PLC/trigger outputs connect all camera supply and PLC supply pins (pin 1, pin 2 and pin 9) in order to limit the connector pin current.

The maximum combined current of all outputs should not exceed 1 A.

3.2.3.1 Connection of PLC/trigger inputs VC nano Z Series

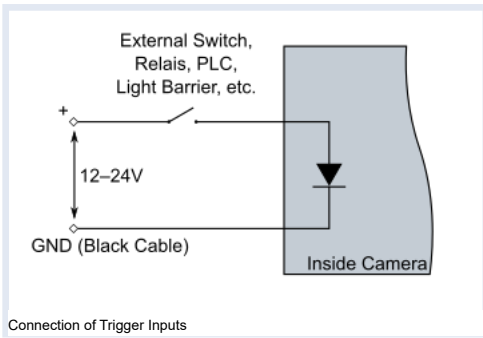

- 2 digital inputs
- 1 trigger input
- Operating Voltage 12 to 24 V
- Threshold Voltage 8V (input high for signals greater 8V)
- Maximum Voltage: 30V
- Reverse voltage protection
- Input Current 2mA @ 24V
- Signal debouncing hardware: none

3.2.3.2 Connection of PLC/trigger outputs VC nano Z Series

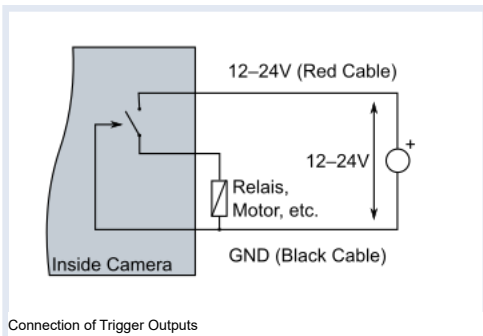

- 4 digital outputs
- 1 trigger output
- Operating Voltage 12 to 24 V
- current per output: 400 mA (total current all outputs < 1000 mA)
- Connect 12-24 V PLC and camera power supply pins 1, 2 and 9.
- bit = 1 output will switch positive voltage
- short-circuit and over-temperature protection (2A)

The outputs are protected with an Infineon BSP742R power switch (http://www.infineon.com/dgdl/Infineon-BSP742R_GDS-DS-v01_03-en.pdf?filed=db3a304320d39d5901210fe1d994367c).

3.2.4 Available Accessories / Cables for Power Supply and IO Interface

Length: 5m

HIROSE 10A-10P-12S
12-pin solder jack

Cable: 0.22 mm² LYCY 12 conductors
shielded, outside diameter 7 mm

Signal	Pin No.	Cable color
OUT0	8	white
OUT1	7	brown
OUT2	6	green
OUT3	5	yellow
IN0	12	grey
IN1	4	pink
Trig IN	11	blue
Trig OUT	10	purple
24V IN Cam	2	red/blue
GND IN com.	3	black
24V PLC	1	red
24V PLC	9	grey / pink

Equipped on one end with a Hirose plug jack, length 5m, 10m or 25m
Refer to section 5.1 for a list of available cables with order numbers.

3.3 VC nano Z Series LED

The VC nano Z Smart Cameras feature 8 LEDs providing status information on power supply, PLC I/Os and trigger input.

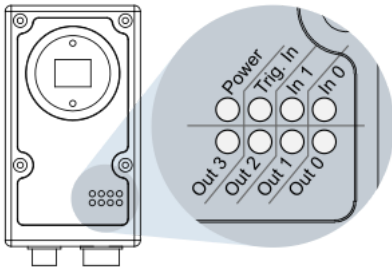

4 Software Interfaces

4.1 GPIOs

Connector Assignment of GPIOs

GPIO Nr.	Pin Designator	Usability	Remark
0	OUT 0	Output	—
1	OUT 1	Output	—
2	OUT 2	Output	—
3	OUT 3	Output	—
4	—	—	—
5	—	—	—
6	—	—	—
7	—	—	—
8	—	—	—
9	—	—	—
10	INP 0	Input	—
11	INP 1	Input	—
12	—	—	—
13	—	—	—
14	—	—	—
15	—	—	—
16	—	—	—
17	—	—	—
18	—	—	—
19	—	—	—
20	—	—	—
21	—	—	—
22	—	—	—
23	—	—	—
24	—	—	—
25	—	—	—
26	—	—	—
27	—	—	—
28	—	—	—
29	—	—	—
30	—	—	—
31(Out)	TrigOut	Output	—
31(In)	TrigIn	Input	Optically isolated

They can be accessed over the linux standard way via `/sys/class/gpio`, see <https://www.kernel.org/doc/Documentation/gpio/sysfs.txt>. The GPIO numbers are relative to the start number of the gpiochip labelled with `'/amba@0/axi-gpio0@41200000'`, here: `/sys/class/gpio/gpiochip224`.

4.2 Trigger Assignment

To choose the sensor input/output trigger signals, the corresponding GPIO Nr. must be determined and assigned by the supporting program named `vcio`. More information can be found at the help of the program, if you run it with no command line parameter, it will show how to do it. Sample usage instructions are provided here, but always refer

5 Accessories

5.1 Camera order numbers

The VC nano Z Series Smart Cameras support by default CS-mount lenses, but standard delivery also includes a 5 mm adjustment ring for C-mount lenses.



VC nano Z Cameras

Order Number	Product / Service description
VK002247	VC nano Z 0010 Smart Camera, b/w sensor
VK002114	VC nano Z 0011 Smart Camera, b/w sensor
VK002130	VC nano Z 0011 Smart Camera, Bayer sensor
VK002183	VC nano Z 0015 Smart Camera, b/w sensor
VK002186	VC nano Z 0015 Smart Camera, Bayer sensor
VK003120	VC nano Z 0252 Smart Camera, b/w sensor
VK003155	VC nano Z 0252 Smart Camera, Bayer sensor
VK000465	VC nano Z 0273 Smart Camera, b/w sensor
VK003164	VC nano Z 0392 Smart Camera, b/w sensor

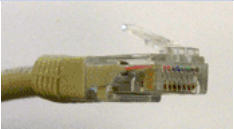

Further models will be offered.

5.2 Order numbers of all available VC nano Z Series Accessories

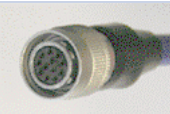

Ethernet Cables

Article Description	Order Number	Camera Connector	Second Connector
5m LAN-C6-Cable	VK000149	HRS connector female 6 pin 	RJ45 
10m LAN-C6-Cable	VK000150	HRS connector female 6 pin	RJ45
25m LAN-C6-Cable	VK000151	HRS connector female 6 pin	RJ45
Ethernet Cross Module	VK000156	 RJ45	RJ45 female socket

Power Supply and IO Interface Cables

Article Description	Order Number	Camera Connector	Second Connector
5m Power / PLC-Cable C6	VK000008	HRS female 12 pin 	without connector 
10m Power / PLC-Cable C6	VK000114	HRS female 12 pin	without connector
25m Power / PLC-Cable C6	VK000161	HRS female 12 pin	without connector

Further Accessories

Article Description	Order Number	Camera Connector
Power Adapter C6 24V, with 12 pins conn. 3m	VK000119	HRS connector female 12 pin 
Power adapter for rail mounting, Input Voltage 100 - 240VAC 50/60 Hz, Output Voltage DC 24V +/-5%, max. 300 mA (7.5 W), Equipped with connecting clamps for AC input and 24V output, CE cert.	VK000036	

6 Appendix A: Block diagram VC nano Z Series

The image is formed by a 1.3 megapixel CMOS sensor (VC nano Z 0011). The image is then stored in the DDR3-SDRAM memory, which has been increased to 512 MB. The VC nano Z Series cameras do not have a direct video output. However if monitoring of the camera image is required, this can be done by transferring via Fast Ethernet port to PC and display on screen.

Block diagram VC nano Z Series:

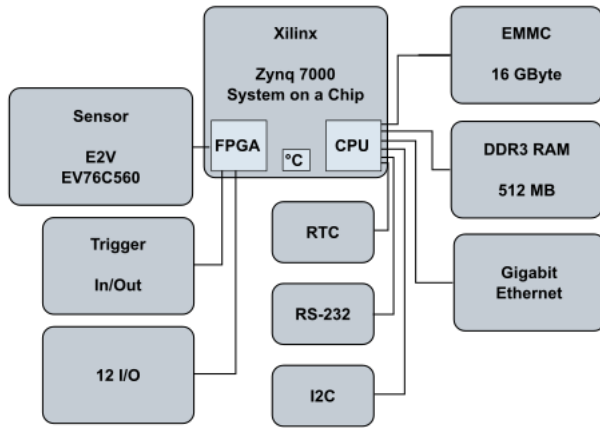

7 Appendix B: Dimensions VC nano Z Series

Warning



Maximal torque for M6 screws: **10 Nm**.

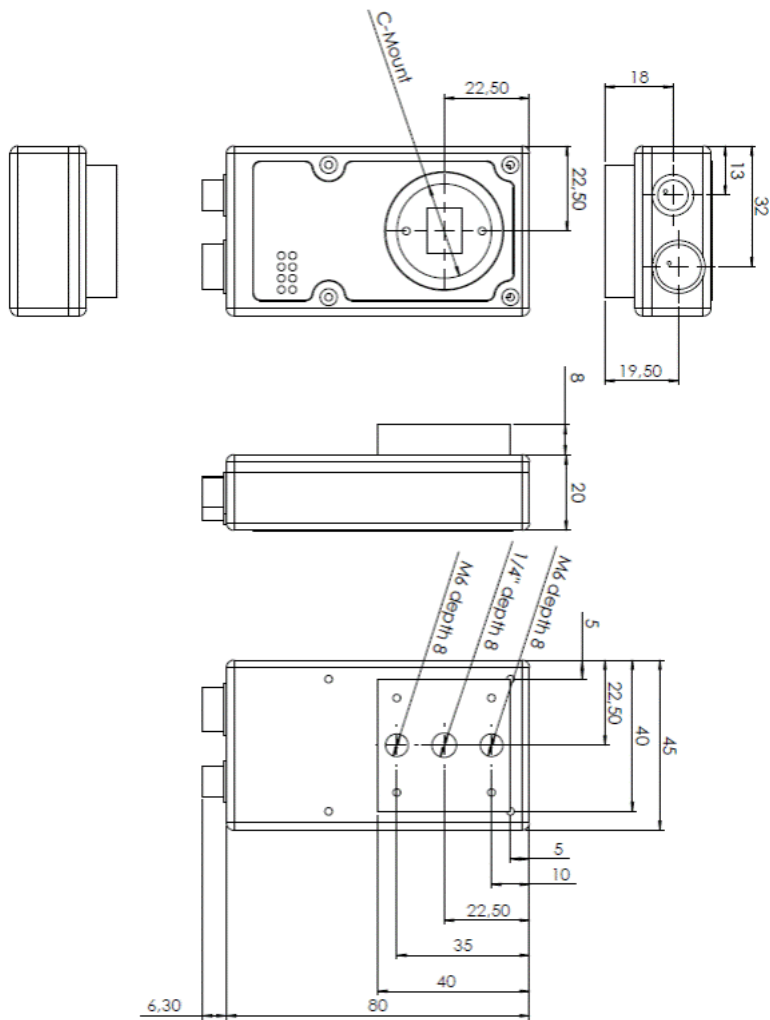

Tolerances: All circuit board dimensions: +/- 0.1

Vision Components GmbH
 Ottostr. 2
 76275 Ettlingen
 Germany

Phone: +49 (0) 7243 2167-0
www.vc-linux.com
www.vision-components.com