



MLVS2220P Series Data Sheet

Product Name	MLVS2220P Series
Series	Multilayer Varistor
Size	EIA 2220
Version	A2

1. Scope

- (1) SMD type zinc oxide based ceramic chip
- (2) RoHS compliant
- (3) Insulator over coat keeps excellent low and stable leakage current
- (4) Quick response time (<1ns)
- (5) Low clamping voltage
- (6) High transient current capability
- (7) High reliability
- (8) Meet IEC 61000-4-5 standard
- (9) Compact size for EIA2220

Applications

Applications for Mother Board and Notebook, Cellular Phone, PDA, handheld device, DSC, DV, Scanner, and Set-Top Box etc.

Suitable for Push-Button, Power Line and Low Frequency single line over voltage protect

2. Explanation of Part Number

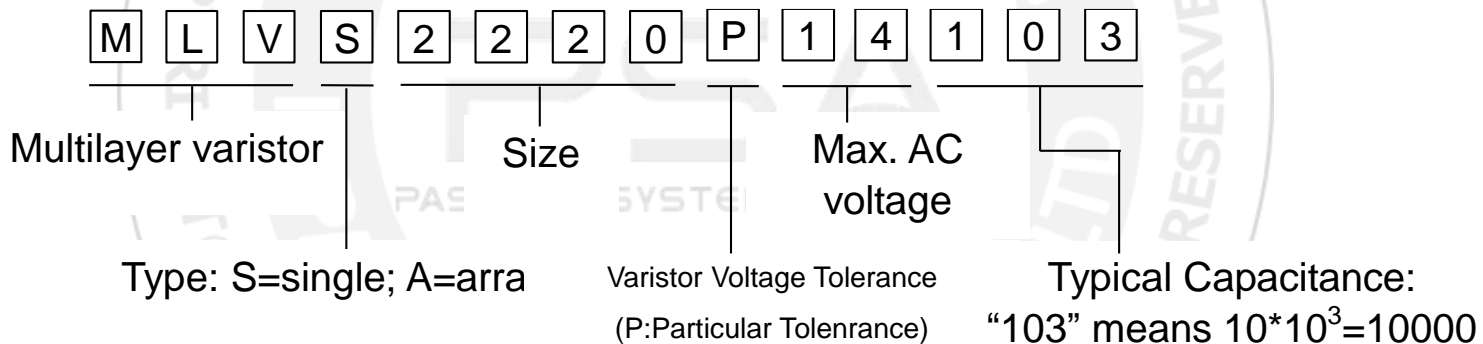

3. Construction & Dimension

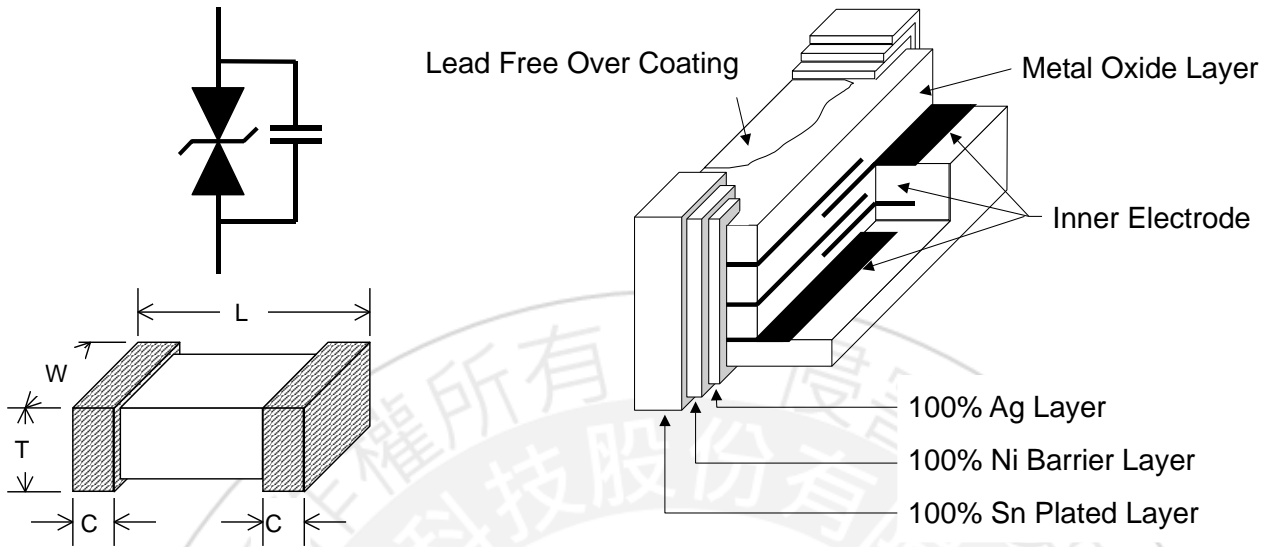

Unit: mm	2220
L	5.70±0.4
W	5.20±0.4
T	3.0 Max./4.0 Max.
C	1.4 Max

4. Part ratings and characteristics

4.1. Ratings (25°C for characteristics, 85°C for maximum ratings)

Symbol	Working voltage		Varistor voltage	Clamping Voltage	Capacitance	Peak current
	V_{RMS}	V_{DC}	V_V	V_c	C_p	i_{max}
Units	Volts	Volts	Volts	Volts	pF	Amps
	(Max.)	(Max.)		(Max.)	(Typical)	(Max.)
Test Condition		$< 50 \mu A$	1mA DC	10A 8/20 μs	1KHz	8/20 μs (1Time)
MLVS2220P14103	14	16	21.4~27.8	55	10000	1500
MLVS2220P14193	14	16	21.4~27.9	55	19000	4000
MLVS2220P14273	14	16	21.4~27.9	55	27000	5000
MLVS2220P30382	30	38	42.3~51.7	77	3800	1200
MLVS2220P50692	50	63	69.3~84.7	115	6900	4500
MLVS2220P50192	50	65	73.8~90.2	135	1900	800
MLVS2220P50652	50	65	73.8~90.2	140	6500	4500
MLVS2220P60102	60	85	90~110	165	1000	800

V_{RMS} – Maximum AC operating voltage the varistor can maintain and not exceed 50 μA leakage current

V_{DC} – Maximum DC operating voltage the varistor can maintain and not exceed 50 μA leakage current

V_V – Voltage across the device measured at 1mA DC current.
Equivalent to V_b , “Breakdown Voltage”.

V_c – Maximum peak voltage across the varistor measured at 8/20 μs waveform

C_p – Device capacitance measured with zero volt bias 1Vrms.

i_{max} – Maximum peak current which may be applied with 8/20 μs waveform without device failure

8/20 μs : Calibration method by short circuit

5. General electrical specifications

5.1. General technical data

Operating temperature	-40 ... +85°C
Storage temperature (on board)	-40 ... +85°C
Response time	<1 ns
Solderability	245±5°C, 5 +0/-0.5sec
Solder leach resistance	260±5°C, 10 ±1sec

5.2. Taping Package Storage Condition

Storage Time: 12 months max.

Storage Temperature: 5 to 40°C

Relative Humidity: 65% max.

6. Precautions for Handling

6.1. Solder cream in reflow soldering

Refer to the recommendable land pattern as printing mask pattern for solder cream.

(1) Print solder in a thickness of 150 to 200 μm

Dimensions: millimeters (inches)

2220

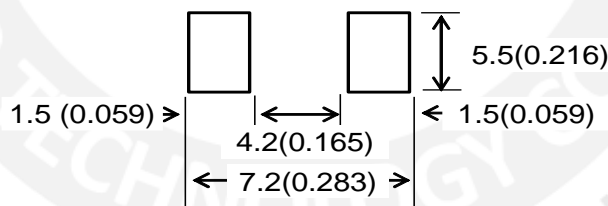

6.2. Precaution for handling of substrate

Do not exceed to bend the board after soldering this product extremely.

(Reference examples)

- Mounting place must be as far as possible from the position, which is close to the break line of board, or on the line of large holes of board.
- Do not bend extremely the board, in mounting another component.
If necessary, use back-up pin (support pin) to prevent from bending extremely.
- Do not break the board by hand. We recommend using the machine or the jig to break it.

6.3. Precaution for soldering

Note that rapid heating, rapid cooling or local heating will easily damage the component.

Do not give heat shock over 100°C in the process of soldering. We recommend taking preheating and gradual cooling.

6.4. Recommendable reflow soldering

Profile Feature	Pb-Free Assembly
Average Ramp-Up Rate (T _{smax} to T _p)	3°C/second max.
Preheat – Temperature Min (T _{smin}) – Temperature Max (T _{smax}) – Time (t _{smin} to t _{smax})	150°C 200°C 60-180 seconds
Time maintained above: – Temperature (T _L) – Time (t _L)	217°C 60-150 seconds
Peak/Classification Temperature (T _p)	260°C
Time within 5 °C of actual Peak Temperature (t _p)	20-40 seconds
Ramp-Down Rate	6°C/second max.
Time 25 °C to Peak Temperature	8 minutes max.

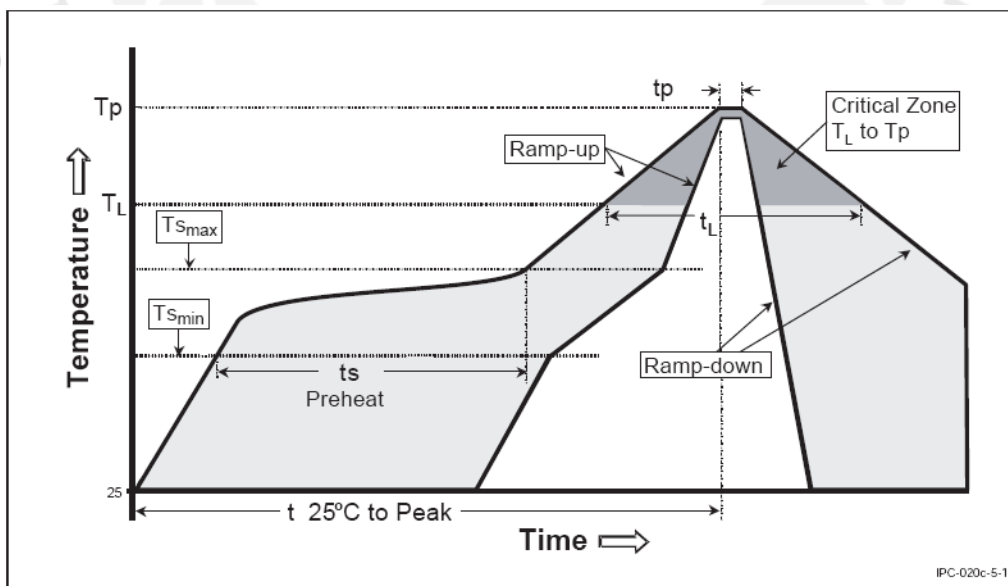

*According to J-STD-020C

6.5. Solder gun procedure

Note the follows, in case of using solder gun for replacement.

- (1) Use solder tip temperature must be less than 350°C for the period within 3 seconds by using soldering gun under 30W.
- (2) Soldering gun tip shall not touch component directly.

6.6. Soldering volume

Apply proper volume of solder paste, too much may cause crack of component body.

7. Taping Package and Label Marking

7.1. Carrier tape dimensions

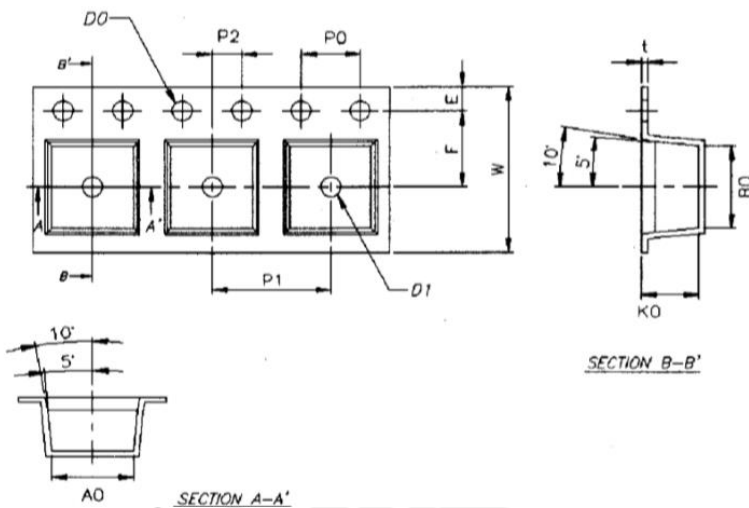

Unit :mm

Type	W	E	F	D0	D1	P0	P1	P2	P0 X10
2220	12.00 ±0.30	1.75 ±0.10	5.5 ±0.05	1.5 +0.10/-0.00	1.5 +0.10/-0.00	4.00 ±0.10	8.00 ±0.10	2.00 ±0.05	40.00 ±0.20
	t	A0	B0	K0					
	0.40 ±0.05	5.45 ±0.05	5.95 ±0.05	4.10 ±0.10					

7.2. Taping reel dimensions

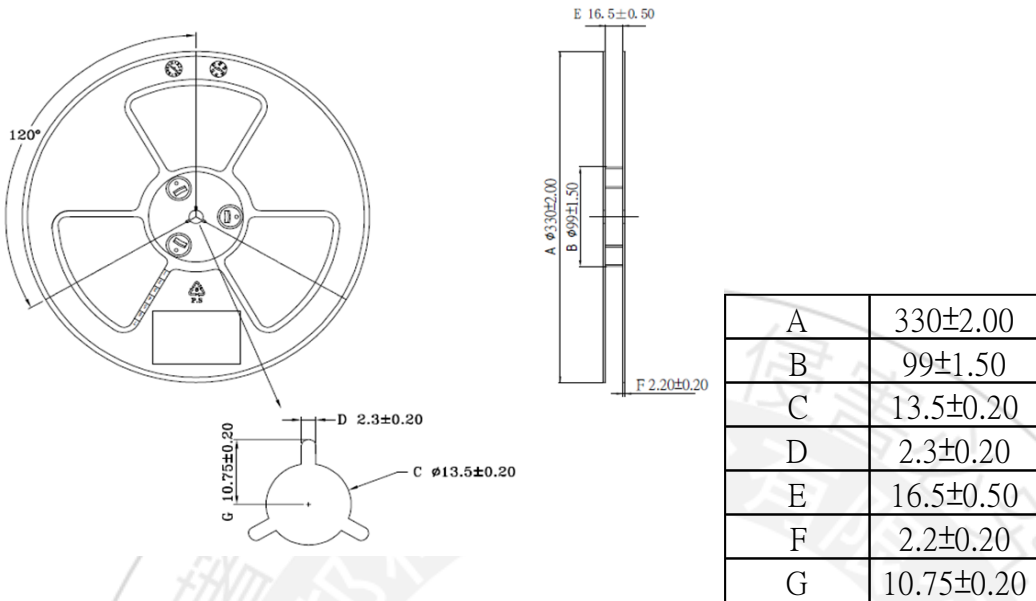

7.3. Taping specifications

There shall be the portion having no product in both the head and the end of taping, and there shall be the cover tape in the head of taping.

7.4. Label Marking

The label specified as follows shall be put on the side of reel.

- (1) Part No.
- (2) Quantity
- (3) Lot No.

Part No. And Quantity shall be marked on outer packaging.

7.5. Quantity of products in the taping package

- (1) Standard quantity: 2,000pcs/Reel
- (2) Shipping quantity is a multiple of standard quantity.