



NA2100

Voltage to Frequency Converter

FEATURES

- Synchronous Operation
- Full-Scale Frequency Set by External System Clock
- 3 V / 5 V Operation
- Low Consumption 3 mW (typ)
- Nominal Input Range 0 to VREF
- VREF Range 2.5 V to VDD
- Internal Reference Voltage 2.5 V
- Maximum Input Frequency 1 MHz
- Operating Temperature Range: -40°C to +125°C
- Package VSP-8-AF(MSOP8*)

*MEET JEDEC MO-187-DA

GENERAL DESCRIPTION

The NA2100 is a voltage to frequency converter (VFC) manufactured using a CMOS process.

Operating from a single supply up to 5.25 V, the NA2100 has an internal 2.5 V bandgap reference voltage, but an external reference supply can also be used. This external reference supply range is up to VDD.

The full-scale output frequency is synchronized to the clock signal on the CLKIN pin. The maximum input frequency of the NA2100 is 1 MHz; for analog input signals varying from 0 V to VREF, the output frequency varies from 10% to 90% of fCLKIN.

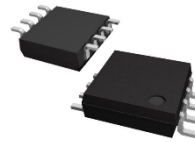

VSP-8-AF
2.8 mm x 2.9 mm x 1.1 mm

APPLICATIONS

- Simple AD converter, simple isolated transmission, etc.

BLOCK DIAGRAM

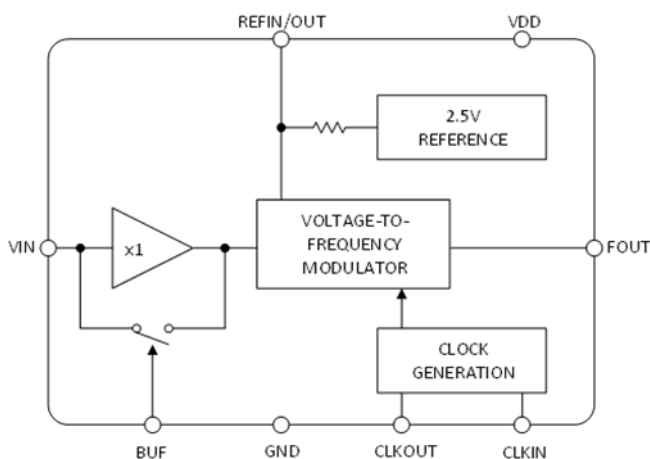

■ PRODUCT NAME INFORMATION

NA2100 aa c dd e

Description of Configuration

Composition	Item	Description
aa	Package Code	Indicates the package. AF: VSP-8-AF
c	Version	Product version A: Specified value
dd	Packing	Taping direction. Refer to the packing specifications.
e	Grade	Indicates the quality grade.

Package code

aa	
AF	VSP-8-AF

Version

c	
A	Specified value

Packaging

dd	
E2	Refer to the packing specifications.

Grade

e	Applications	Operating Temperature Range	Test Temperature
D	Industrial equipment and Social infrastructures	- 40°C to 125°C	25°C, 125°C

■ ORDER INFORMATION

PRODUCT NAME	PACKAGE	RoHS	HALOGEN-FREE	PLATING COMPOSITION	WEIGHT (mg)	QUANTITY (pcs/reel)
NA2100AFAE2D	VSP-8-AF	✓	✓	Sn2Bi	21	2000

■ PIN DESCRIPTIONS

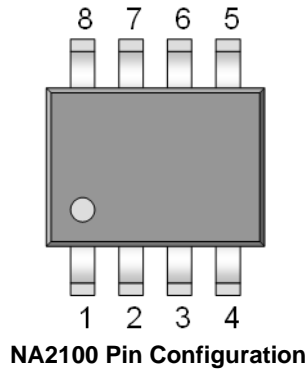

Pin No.	Pin Name	I/O	Description
1	CLKOUT	O	Connection Pin when resonator/oscillator is used. In case of clock input, inverted clock signal is output.
2	CLKIN	I	Clock Input Pin Automatically powers down when CLKIN remains low for 1 ms (typ).
3	GND		Ground
4	REFIN/ OUT	I/O	Reference Voltage Input and Internal Reference Voltage Output Pin If there is no external reference input, 2.5V is output and it is used only as a reference power supply for the NA2100. There is no capacitor to GND is required.
5	VIN	I	Analog Input Pin
6	VDD	Power	Power Supply Input Pin
7	FOUT	O	Frequency Output Pin
8	BUF	I	Buffer Mode Select Pin

■ ABSOLUTE MAXIMUM RATINGS

	Symbol	Ratings	Unit
Power Supply Input Voltage	V_{DDabs}	+7	V
Analog Input Pin Voltage	V_{AI}	-0.3 to VDD+0.3	V
Reference Voltage Input Pin Voltage	V_{VREF}	-0.3 to VDD+0.3	V
Logic Input Pin Voltage	V_{LI}	-0.3 to VDD+0.3	V
FOUT Pin Voltage	V_{FOUT}	-0.3 to VDD+0.3	V
Junction Temperature Range	T_j	-40 to +150	°C
Storage Temperature Range	T_{stg}	-40 to +150	°C

ABSOLUTE MAXIMUM RATINGS

Electronic and mechanical stress momentarily exceeded absolute maximum ratings may cause permanent damage and may degrade the lifetime and safety for both device and system using the device in the field. The functional operation at or over these absolute maximum ratings is not assured.

■ THERMAL CHARACTERISTICS

Package	Parameter	Measurement Result	Unit
VSP-8-AF	Thermal Resistance (θ_{ja})	252 (2Layer) 189 (4Layer)	°C / W
	Thermal Characterization Parameter (ψ_{jt})	62 (2Layer) 53 (4Layer)	

θ_{ja} : Junction-to-Ambient Thermal Resistance

ψ_{jt} : Junction-to-Top Thermal Characterization Parameter

2Layer Mounted on glass epoxy board
(76.2 mm × 114.3 mm × 1.6 mm: based on EIA/JEDEC standard, 2-layer FR-4).

4Layer Mounted on glass epoxy board
(76.2 mm × 114.3 mm × 1.6 mm: based on EIA/JEDEC standard, 4-layer FR-4),
internal Cu area: 74.2 mm × 74.2 mm.

■ ELECTROSTATIC DISCHARGE RATINGS

	Conditions	Protection Voltage
HBM	C = 100pF, R = 1.5kΩ	±2000V
CDM		±1000V

ELECTROSTATIC DISCHARGE RATINGS

The electrostatic discharge test is done based on JEDEC JS001 and JS002.
 In the HBM method, ESD is applied using the power supply pin and GND pin as reference pins.

■ RECOMMENDED OPERATING CONDITIONS

	Symbol	Ratings	Unit
Power Supply Input Voltage	V _{DD}	3.0 to 5.25	V
Nominal Input Range	V _{IN}	0 to V _{REF}	V
Input Frequency	f _{CLKIN}	32 to 1,000	kHz
Operating Temperature Range	T _a	-40 to +125	°C

RECOMMENDED OPERATING CONDITIONS

All of electronic equipment should be designed that the mounted semiconductor devices operate within the recommended operating conditions. The semiconductor devices cannot operate normally over the recommended operating conditions, even if when they are used over such conditions by momentary electronic noise or surge. And the semiconductor devices may receive serious damage when they continue to operate over the recommended operating conditions.

■ ELECTRICAL CHARACTERISTICS

VDD=3.3V, 5V, REFIN=2.5V, CLKIN=1MHz, Ta=-40°C to 125°C unless otherwise specified.

Parameter	Symbol	Conditions	MIN	TYP	MAX	Unit
DC Characteristics						
Integral Nonlinearity CLKIN=32kHz_1	INL	Unbuffer Mode, External Clock Input	-	±0.012	-	% of Span
CLKIN=1MHz_1		Unbuffer Mode, External Clock Input, Ta=25°C	-	-	±0.012	
CLKIN=32kHz_2		Buffer Mode, External Clock Input	-	±0.018	-	
CLKIN=1MHz_2		Buffer Mode, External Clock Input, Ta=25°C	-	-	±0.018	
Offset Voltage Error	V _{error}	Unbuffer Mode, VIN=0V	-	±0.2	±20	mV
		Buffer Mode, VIN=0.2V	-	±0.2	±20	
Gain Error	Gain _{error}		-	±0.1	±0.7	% of Span
Offset Voltage Error Drift	V _{error_drift}		-	±10	-	µV/°C
Gain Error Drift	Gain _{error_drift}		-	±4	-	ppm of Span/°C
Ripple Rejection	PSRR	ΔVDD=±5% (5V)	-	-55	-	dB
		ΔVDD=±10% (3.3V)	-	-65	-	
Analog Input Block						
Nominal Input Range	V _{IN}	Unbuffer Mode,	-	0-V _{REF}	-	V
		Buffer Mode	0.2	-	VDD-0.2	
Input Current	I _{IN}	Unbuffer Mode, VIN=5.4V, REFIN=5.25V	-	12	20	µA
		Buffer Mode, VIN=0.2V, REFIN=2.5V	-	10	100	nA
Reference Voltage Block						
Reference Voltage Input Nominal Input Range	V _{REFIN}		2.3	-	V _{DD}	V
Reference Voltage Output Output Voltage	V _{REF}		2.3	2.5	2.7	V
Output Impedance	Z _{REF}		-	1	-	kΩ
Reference Voltage Drift	V _{REF_drift}		-	±25	-	ppm/°C
Ripple Rejection	PSRR _{REF}	ΔVDD=±5% (5V)	-	-75	-	dB
		ΔVDD=±10% (3.3V)	-	-65	-	
Reference Voltage Noise	V _{NOISE}	0.1Hz to 10Hz	-	100	-	µVp-p
Frequency Output Block						
Nominal Frequency Range	F _{OUT}	VIN=0V to V _{REF}	0.1 fCLKIN	-	0.9 fCLKIN	Hz

■ ELECTRICAL CHARACTERISTICS

V_{DD}=3.3V, 5V, REFIN=2.5V, CLKIN=1MHz, Ta=-40°C to 125°C unless otherwise specified.

Parameter	Symbol	Conditions	MIN	TYP	MAX	Unit
Logic Input Block						
CLKIN						
Input Frequency	f _{CLKIN}		32	–	1000	kHz
Input High Voltage 1	V _{IH1_CI}	VDD=5V±5%	3.5	–	–	V
Input High Voltage 2	V _{IH2_CI}	VDD=3.3V±10%	2.5	–	–	V
Input Low Voltage 1	V _{IL1_CI}	VDD=5V±5%	–	–	0.8	V
Input Low Voltage 2	V _{IL2_CI}	VDD=3.3V±10%	–	–	0.4	V
Input Current	I _{IN_CI}	VIN=0V to V _{DD}	–	–	±2	µA
Pin Capacitance	C _{PIN_CI}		–	5	–	pF
BUF						
Input High Voltage 1	V _{IH1_BUF}	VDD=5V±5%	2.4	–	–	V
Input High Voltage 2	V _{IH2_BUF}	VDD=3.3V±10%	2.1	–	–	V
Input Low Voltage 1	V _{IL1_BUF}	VDD=5V±5%	–	–	0.8	V
Input Low Voltage 2	V _{IL2_BUF}	VDD=3.3V±10%	–	–	0.4	V
Input Current	I _{IN_BUF}		–	–	±100	nA
Pin Capacitance	C _{PIN_BUF}		–	5	–	pF
Logic Output Block						
FOUT						
Output High Voltage1	V _{OH1_FO}	Output Source Current 1.6mA, VDD=5V±5%	4.0	–	–	V
Output High Voltage2	V _{OH2_FO}	Output Source Current 1.6mA, VDD=3.3V±10%	2.1	–	–	
Output Low Voltage	V _{OL_FO}	Output Sink Current 1.6mA	–	–	0.4	
CLKOUT						
Output High Voltage1	V _{OH1_CO}	Output Source Current 200µA, VDD=5V±5%	4.0	–	–	V
Output High Voltage2	V _{OH2_CO}	Output Source Current 200µA, VDD=3.3V±10%	2.1	–	–	
Output Low Voltage	V _{OL_CO}	Output Sink Current 200µA	–	–	0.4	
Power Supply Condition						
Input Voltage Range	V _{DD}		3.0	–	5.25	V
Quiescent Current 1	I _{DD_UNBUF}	V _{IH} =V _{DD} , V _{IL} =GND, Unbuffer Mode	–	0.95	1.35	mA
Quiescent Current 2	I _{DD_BUF}	V _{IH} =V _{DD} , V _{IL} =GND, Buffer Mode	–	1.15	1.75	mA
Quiescent Current 3	I _{DD_PD}		–	30	100	µA
Turn On Time	t _{WAKE}	Exiting Power-Down (Ext. Clock at CLKIN)	–	3	–	µs

■ TIMING CHARACTERISTICS

V_{DD}=3.3V, 5V, REFIN=2.5V, CLKIN=1MHz, Ta=-40°C to 125°C unless otherwise specified.

Parameter	Symbol	Conditions	MIN	TYP	MAX	Unit
Clock Frequency	f _{CLKIN}	VDD=3.3V	32	-	1000	kHz
		VDD=5V	32	-	1000	
Clock Mark/Space Ratio	t _{HIGH} :t _{LOW}	VDD=3.3V	40:60	-	60:40	
		VDD=5V	40:60	-	60:40	
Clock Input Frequency Output Delay Time	t ₁	VDD=3.3V	-	50	-	ns
		VDD=5V	-	35	-	
Frequency Output Rise Time	t ₂	VDD=3.3V	-	2.3	-	ns
		VDD=5V	-	1.8	-	
Frequency Output Fall Time	t ₃	VDD=3.3V	-	1.6	-	ns
		VDD=5V	-	1.4	-	
Frequency Output Pulse width	t ₄	VDD=3.3V	-	t _{HIGH} ±20	-	ns
		VDD=5V	-	t _{HIGH} ±8	-	

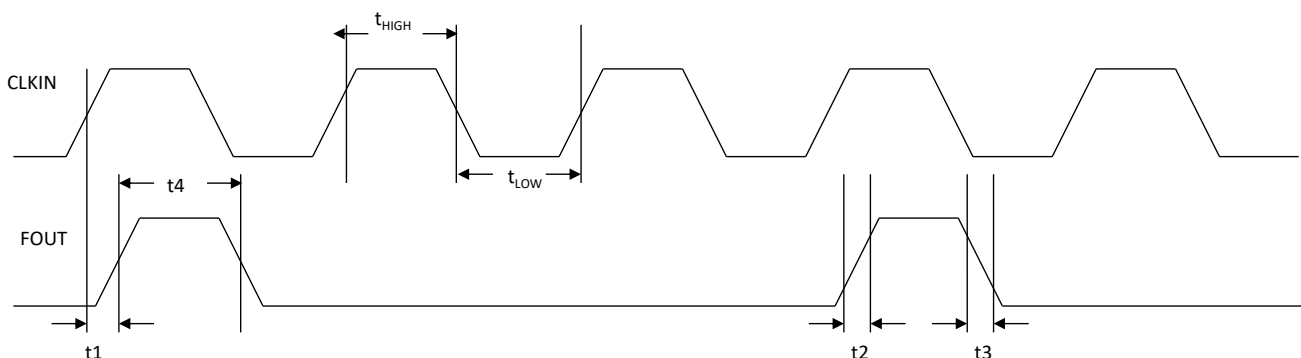

■ GENERAL DISCRIPTION

NA2100 is a voltage frequency converter (VFC). The input voltage signal is applied to a front end centered around an analog modulator that converts the input voltage into an output pulse train. The NA2100 operates from 3.3 V or 5 V power supplies. It also has a built-in 2.5 V reference power supply.

■ Input Amplifier Buffering and Voltage Range

Analog input VIN can be buffered by setting BUF = High. This provides a high impedance of 100 MΩ, allowing it to tolerate large external impedances. The VIN voltage range is 0.2 V to VDD - 0.2 V. When BUF = Low, the NA2100 input circuit accepts analog inputs below GND, so the analog input VIN voltage range is -0.15 V to VDD + 0.15 V. In this case, the input impedance will be 450kΩ(typ.).

The transfer function of NA2100 is expressed by the following formula.

$$F_{OUT} = 0.1 f_{CLKIN} + 0.8 (VIN/VREF) f_{CLKIN}$$

Figure 1 shows unbuffered mode.

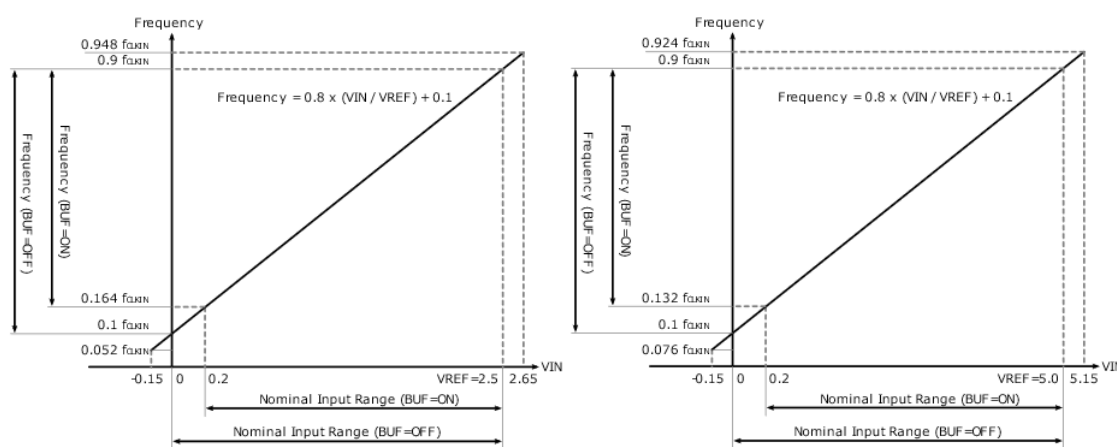

■ VFC Modulator

Digital data representing the analog input voltage is contained within the duty cycle of the pulse train output by the comparator.

The output is a pulse train whose frequency depends on the analog input signal. A full-scale input gives an output frequency of 0.9 fCLKIN, and a zero-scale input gives an output frequency of 0.1 fCLKIN. The FOUT pulse width is fixed and determined by the CLKIN high level section. This pulse is synchronous to the rising edge of the clock signal. The delay time between the edge of CLKIN and the edge of FOUT is 35 ns (typ.). Figure 2 shows the waveform of this frequency output (see Power On Time Characteristic Example).

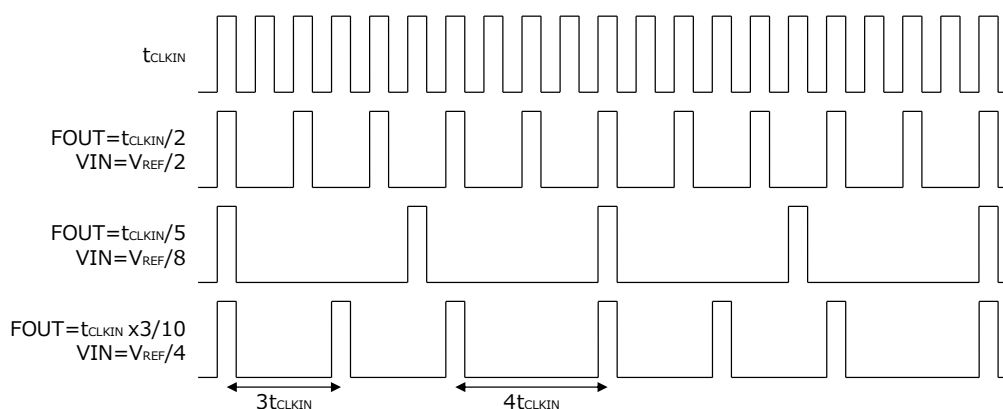

When a step change in input voltage occurs, a settling time is required before valid data can be obtained. This is 2 cycles (typ.) of CLKIN.

■ Clock Generation

The NA2100 uses an external clock to determine the full-scale output frequency. The NA2100 requires a master clock input, which can be obtained from an external clock signal connected to the CLKIN pin (CLKOUT pin left unconnected). If frequency = 1 MHz, a crystal or resonator can be connected between CLKIN and CLKOUT so that the clock circuit acts as a crystal-controlled oscillator. The NA2100 master clock is inverted and output from the CLKOUT pin.

■ Reference Input

The NA2100 performs conversions based on the input reference voltage. REFIN/OUT can be left unconnected and derived from the internal 2.5V reference voltage. Alternatively, an external reference voltage can be used. Connect this to the REFIN/OUT pin to override the internal reference voltage. When selecting an external reference voltage, drive capability, voltage error, noise, and drift characteristics must be considered. NJM17431 is suitable as this external reference voltage.

■ Power-Down Mode

The NA2100 automatically powers down when CLKIN goes low for 1 ms (typ.). During power down, REFOUT is floating and FOUT is low level.

■ Typical Application

A basic connection diagram of the NA2100 is shown in Figure 3, left. In this connection diagram, the device is set to unbuffered mode: the 5 V supply is used as the reference voltage and the oscillator is the device's master clock source (32 kHz to 1 MHz). The device can also be operated with a crystal oscillator (Fig. 3, right) (1 MHz is recommended)

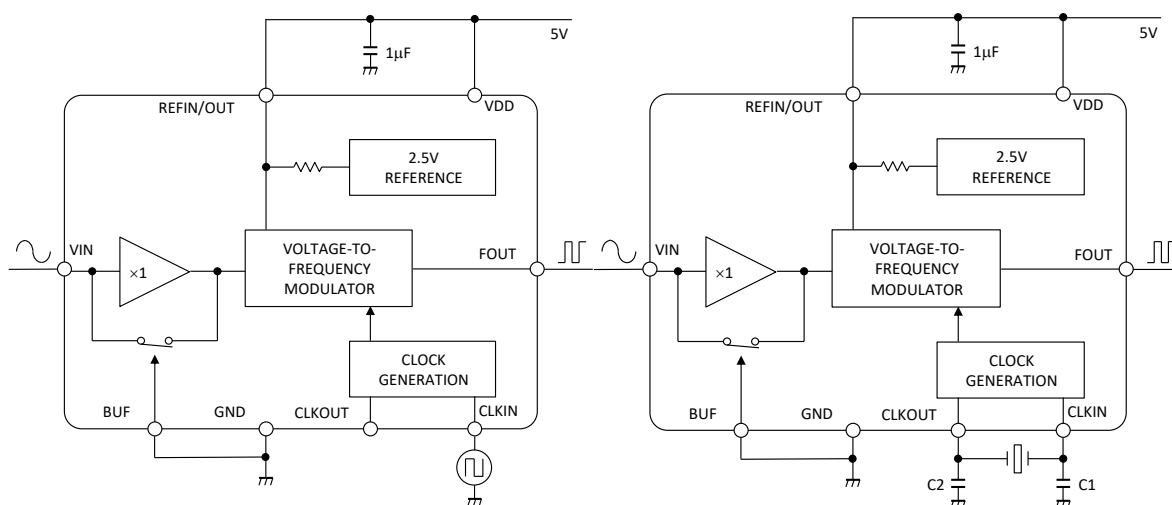

Figure3: Basic Connection Diagram Left , Right

■ Isolation Application

The NA2100 can be used in isolated transmission applications. This can be achieved using a photo-coupler.

■ MARKING SPECIFICATION

(1)(2)(3)(4)(5)(6)(7): Product Code ... **Refer to the following table**

(8) to (12): Lot Number ... Alphanumeric Serial Number

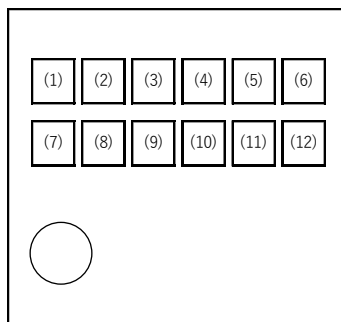

1Pin

NA2100AF AE2D Marking Specification

NOTICE
There can be variation in the marking when different AOI (Automated Optical Inspection) equipment is used. In the case of recognizing the marking characteristic with AOI, please contact our sales or distributor before attempting to use AOI.

NA2100 Marking List (VSP-8-AF)

Product Name	(1)	(2)	(3)	(4)	(5)	(6)	(7)
NA2100AF AE2D	A	2	1	0	0	A	D

■ TYPICAL CHARACTERISTICS

Note: Typical Characteristics are intended to be used as reference data; they are not guaranteed.

INL vs VIN (REFIN=2.5V)

UNBUF mode

VDD=5V, REFIN=2.5V, CLKIN=1MHz

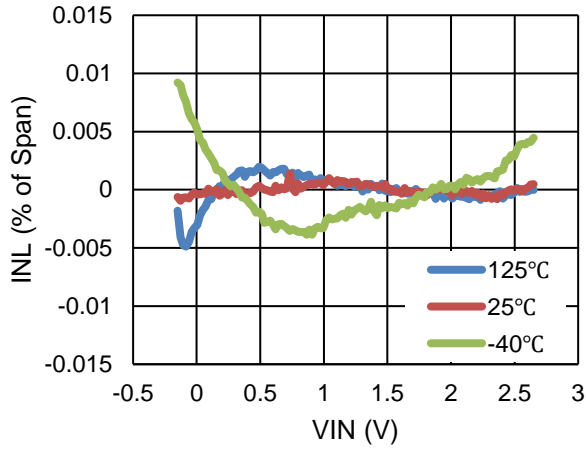

BUF mode

VDD=5V, REFIN=2.5V, CLKIN=1MHz

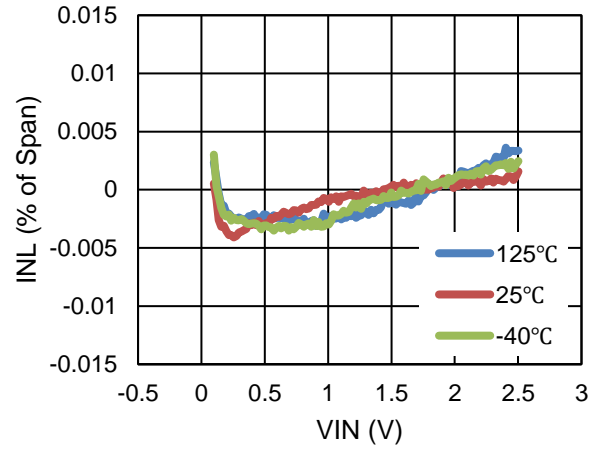

INL vs VIN (REFIN=5V)

UNBUF mode

VDD=5V, REFIN=5V, Ta=25°C

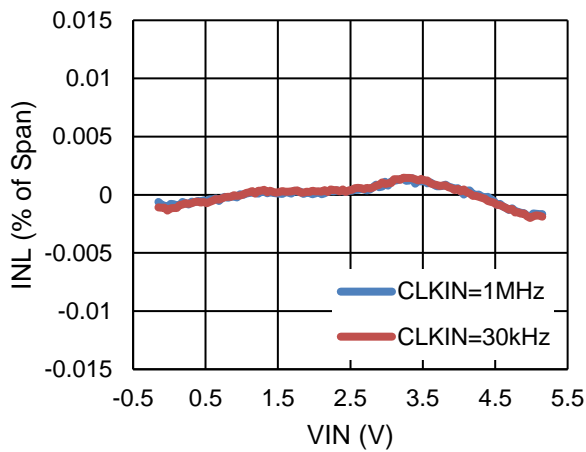

BUF mode

VDD=5V, REFIN=5V, Ta=25°C

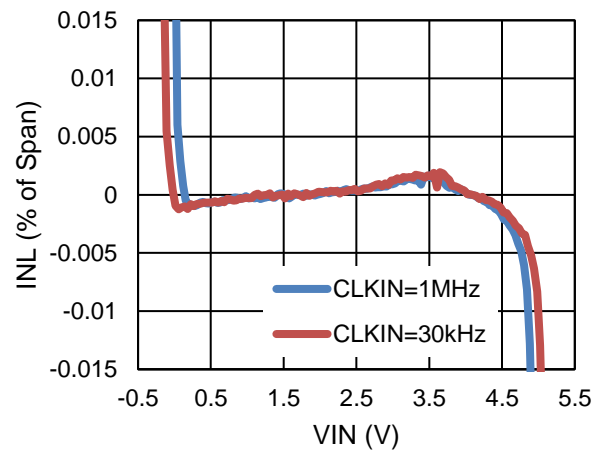

Offset Error vs Temperature

UNBUF mode

REFIN=2.5V, CLKIN=1MHz, VIN=0V

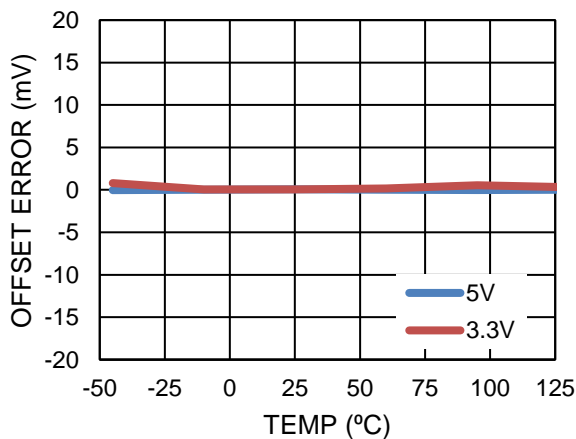

BUF mode

REFIN=2.5V, CLKIN=1MHz, VIN=0.1V

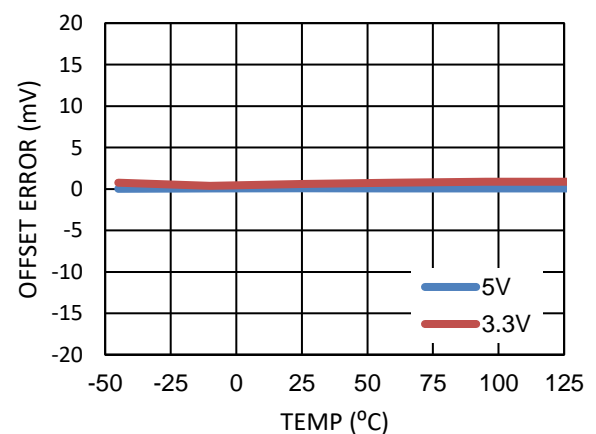

■ TYPICAL CHARACTERISTICS

Note: Typical Characteristics are intended to be used as reference data; they are not guaranteed.

Gain Error vs Temperature
UNBUF Mode
REFIN=2.5V, CLKIN=1MHz

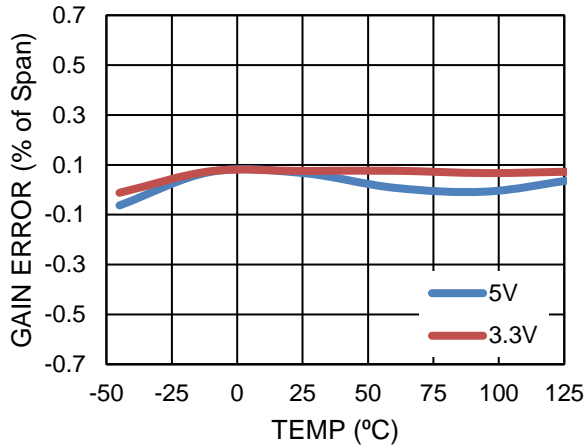

BUF Mode
REFIN=2.5V, CLKIN=1MHz

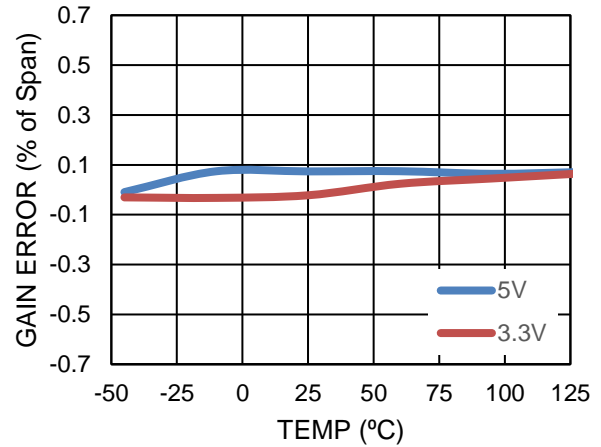

IDD vs VDD

REFIN=2.5V, CLKIN=1MHz, Ta=25°C

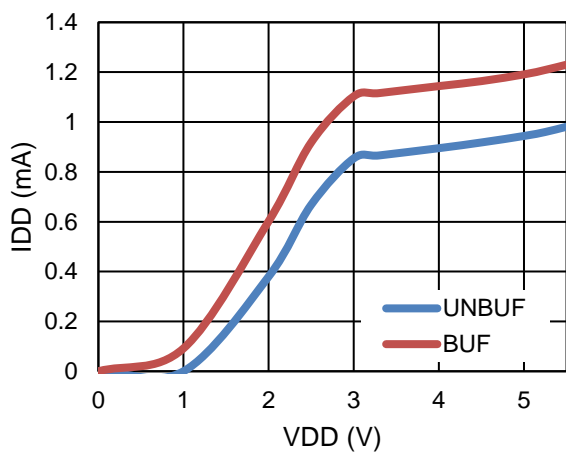

IDD vs Temperature

VDD=5V, REFIN=2.5V, CLKIN=1MHz

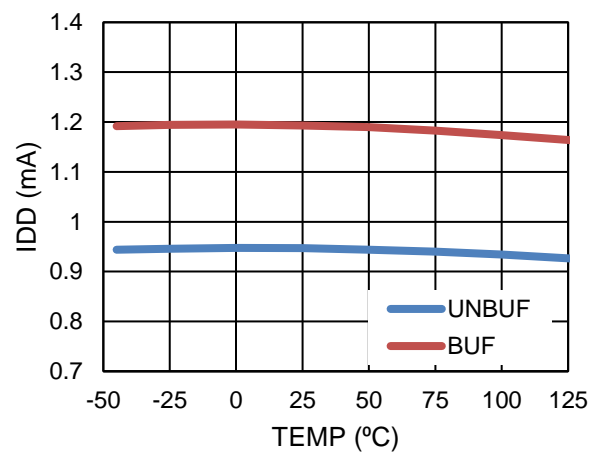

IDD vs Load Capacitance of FOUT(C_FOUT)

VDD=5V, Ta=25°C, INTREF, VIN=0.1V, CLKIN=1MHz

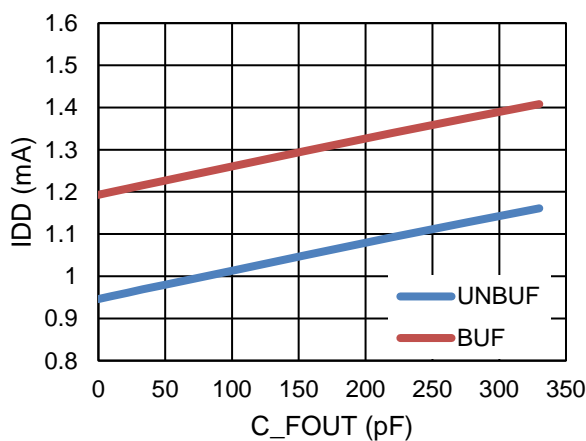

IDD vs Load Capacitance of CLKOUT(C_CLKOUT)

VDD=5V, Ta=25°C, INTREF, VIN=0.1V, CLKIN=1MHz

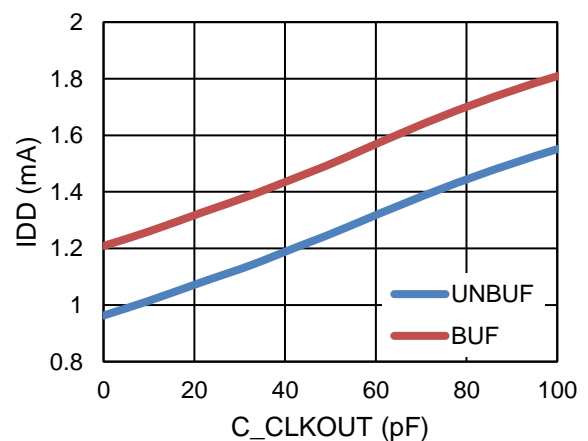

■ TYPICAL CHARACTERISTICS

Note: Typical Characteristics are intended to be used as reference data; they are not guaranteed.

IDD vs CLKIN Frequency

VDD=5V, Ta=25°C, VIN=0.1V

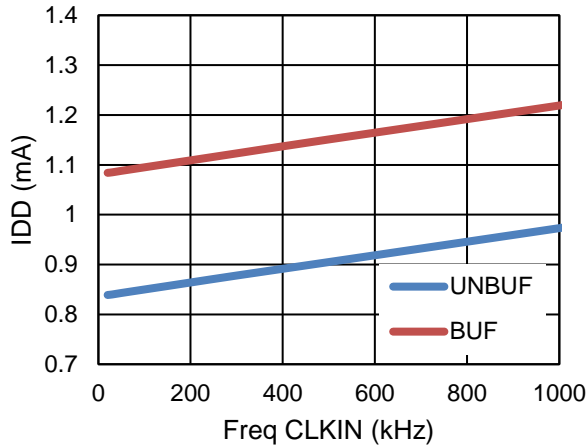

REFOUT Histogram

N=50

VDD=5V, UNBUF mode, CLKIN=1MHz, VIN=0V, Ta=25°C

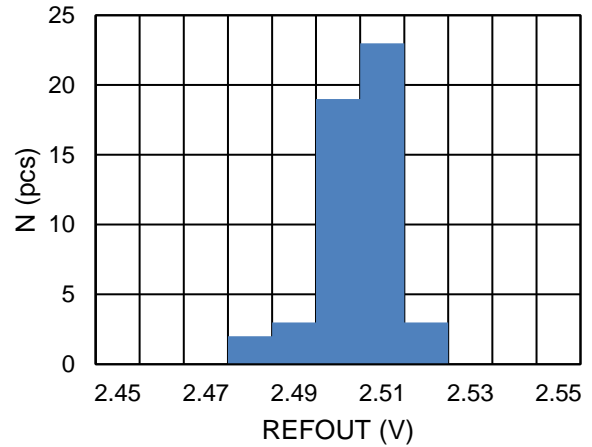

REFOUT vs Temperature

VDD=5V, UNBUF mode, CLKIN=1MHz, VIN=0V

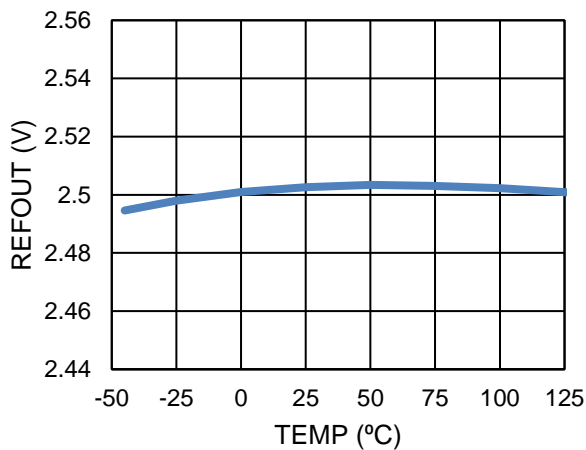

REFOUT vs Load Current

VDD=5V, UNBUF mode, CLKIN=1MHz, VIN=0V

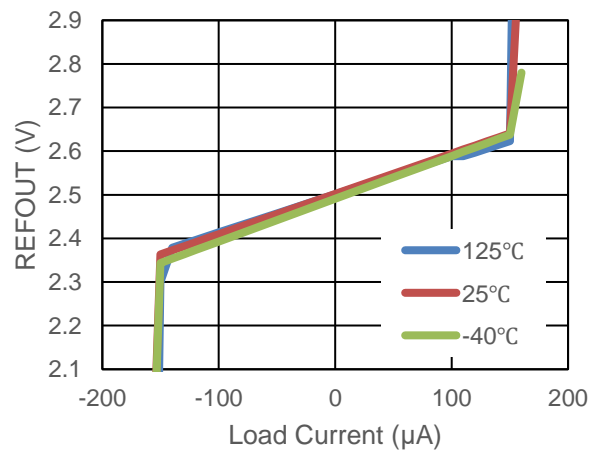

Power On Time

Power On Time = 3µs

VDD=5V, Ta=25°C, CLKIN=1MHz

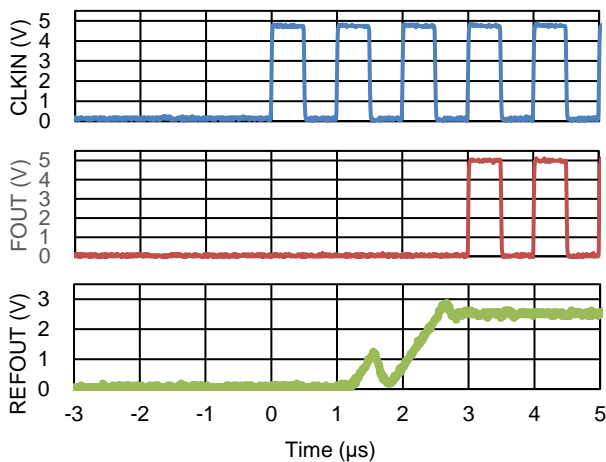

Power Down Time

Power Down Time = 0.94ms

VDD=5V, Ta=25°C, CLKIN=1MHz

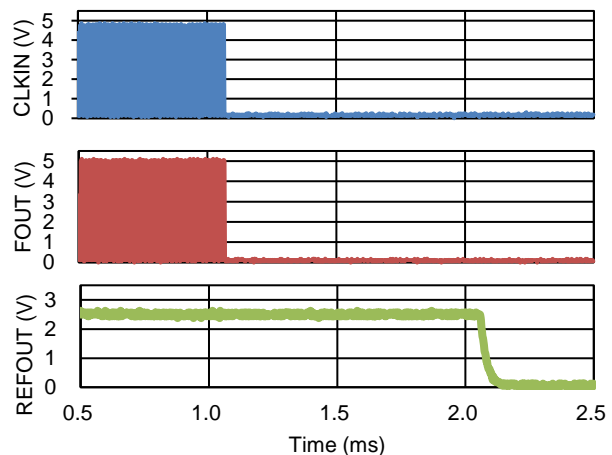

Nisshinbo Micro Devices Inc.

VSP-8-AF

PI-VSP-8-AF-E-A

■ PACKAGE DIMENSIONS

UNIT: mm

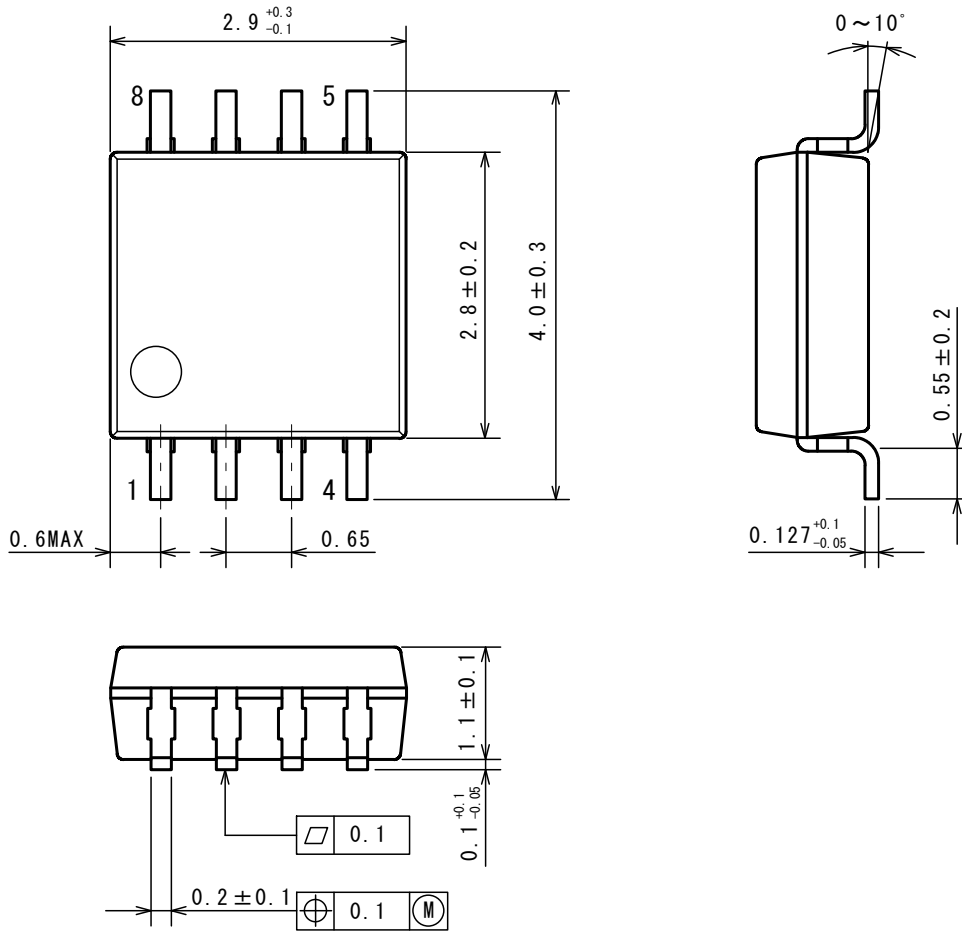

■ EXAMPLE OF SOLDER PADS DIMENSIONS

UNIT: mm

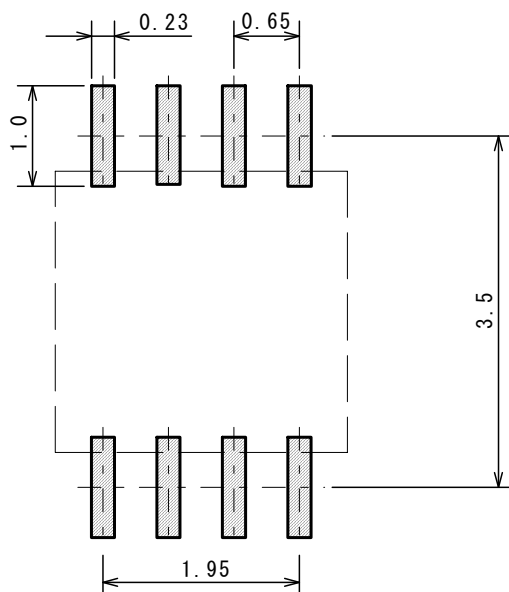

Nisshinbo Micro Devices Inc.

VSP-8-AF

PI-VSP-8-AF-E-A

■ PACKING SPEC

UNIT: mm

(1) Taping dimensions / Insert direction

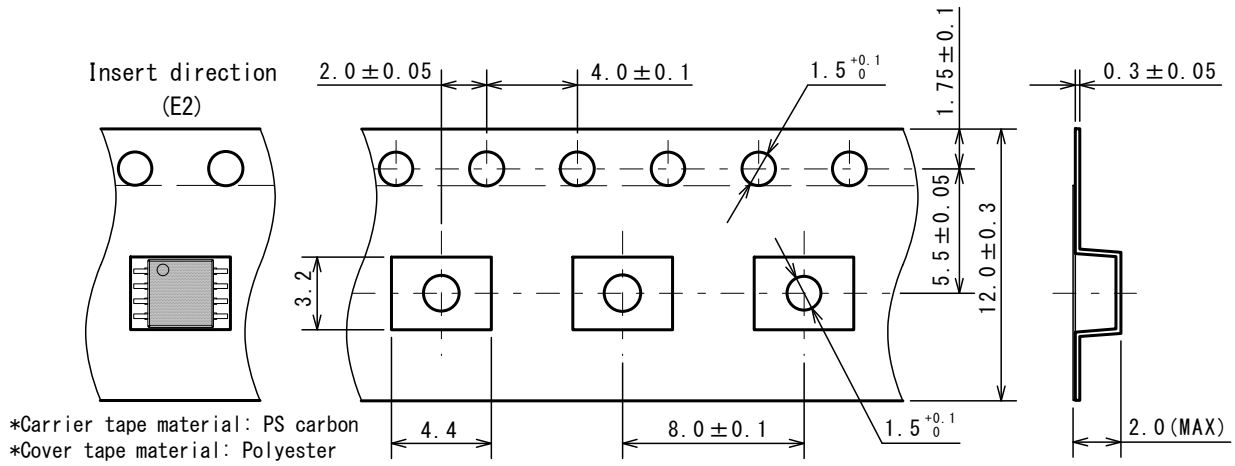

(2) Taping state

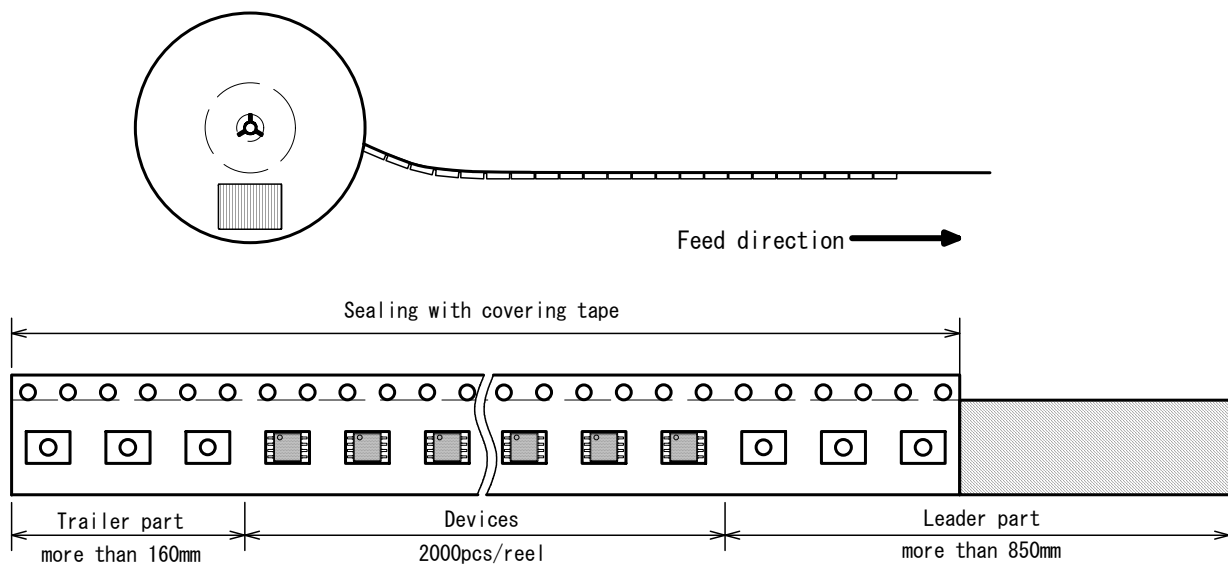

Nisshinbo Micro Devices Inc.

VSP-8-AF

PI-VSP-8-AF-E-A

(3) Reel dimensions

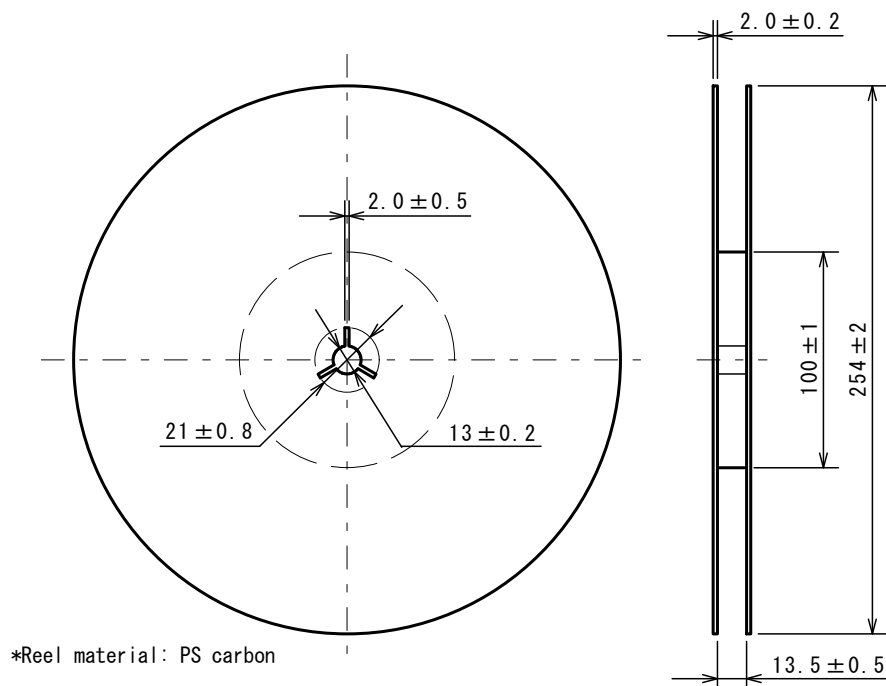

(4) Peeling strength

Peeling strength of cover tape

- Peeling angle 165 to 180° degrees to the taped surface.
- Peeling speed 300mm/min
- Peeling strength 0.1 to 1.3N

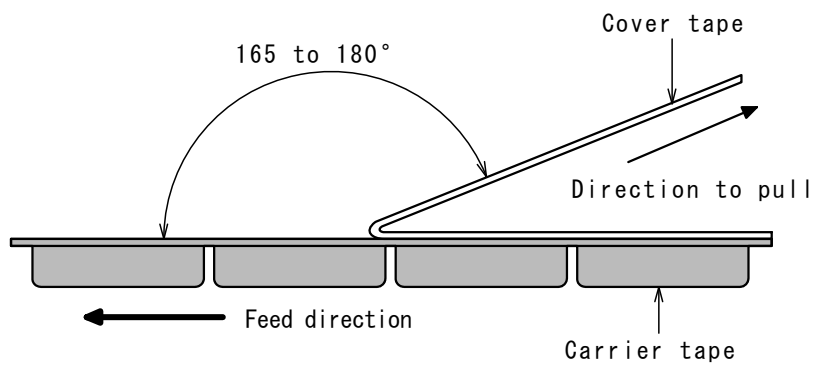

(5) Packing state

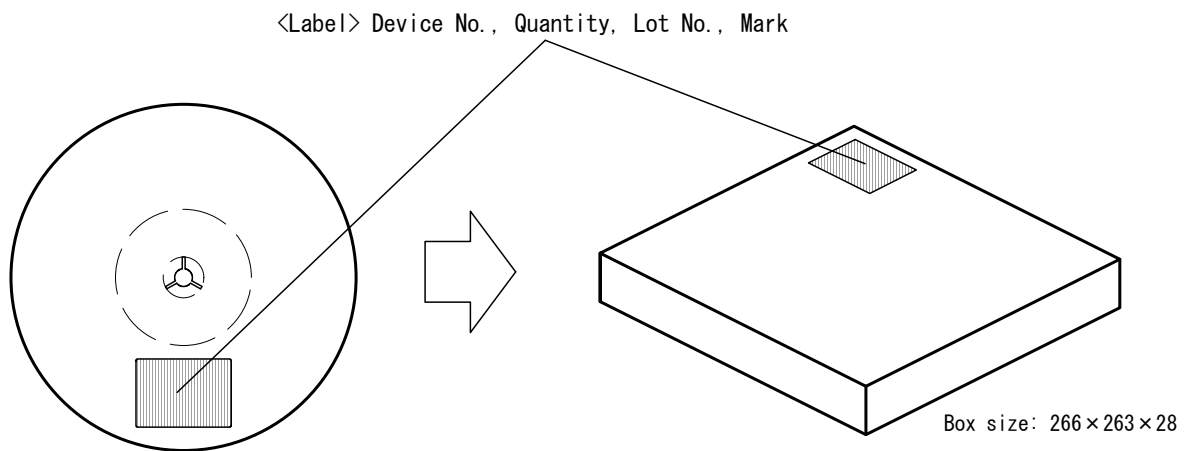

■ HEAT-RESISTANCE PROFILES

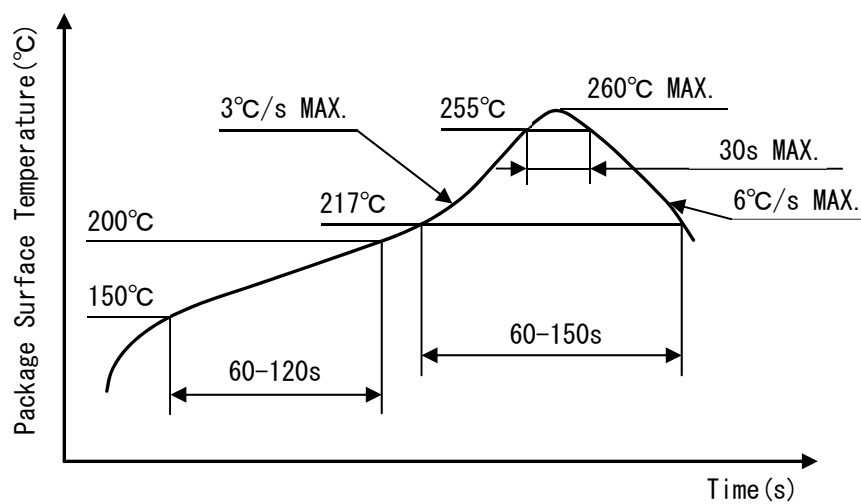

Reflow profile

■ Revision History

Date	Revision	Changes
June 18, 2024	Ver. 1.0	Initial release

1. The products and the product specifications described in this document are subject to change or discontinuation of production without notice for reasons such as improvement. Therefore, before deciding to use the products, please refer to our sales representatives for the latest information thereon.
2. The materials in this document may not be copied or otherwise reproduced in whole or in part without the prior written consent of us.
3. This product and any technical information relating thereto are subject to complementary export controls (so-called KNOW controls) under the Foreign Exchange and Foreign Trade Law, and related politics ministerial ordinance of the law. (Note that the complementary export controls are inapplicable to any application-specific products, except rockets and pilotless aircraft, that are insusceptible to design or program changes.) Accordingly, when exporting or carrying abroad this product, follow the Foreign Exchange and Foreign Trade Control Law and its related regulations with respect to the complementary export controls.
4. The technical information described in this document shows typical characteristics and example application circuits for the products. The release of such information is not to be construed as a warranty of or a grant of license under our or any third party's intellectual property rights or any other rights.
5. The products listed in this document are intended and designed for use as general electronic components in standard applications (office equipment, telecommunication equipment, measuring instruments, consumer electronic products, amusement equipment etc.). Those customers intending to use a product in an application requiring extreme quality and reliability, for example, in a highly specific application where the failure or misoperation of the product could result in human injury or death should first contact us.
 - Aerospace Equipment
 - Equipment Used in the Deep Sea
 - Power Generator Control Equipment (nuclear, steam, hydraulic, etc.)
 - Life Maintenance Medical Equipment
 - Fire Alarms / Intruder Detectors
 - Vehicle Control Equipment (automotive, airplane, railroad, ship, etc.)
 - Various Safety Devices
 - Traffic control system
 - Combustion equipment

In case your company desires to use this product for any applications other than general electronic equipment mentioned above, make sure to contact our company in advance. Note that the important requirements mentioned in this section are not applicable to cases where operation requirements such as application conditions are confirmed by our company in writing after consultation with your company.

6. We are making our continuous effort to improve the quality and reliability of our products, but semiconductor products are likely to fail with certain probability. In order to prevent any injury to persons or damages to property resulting from such failure, customers should be careful enough to incorporate safety measures in their design, such as redundancy feature, fire containment feature and fail-safe feature. We do not assume any liability or responsibility for any loss or damage arising from misuse or inappropriate use of the products.
7. The products have been designed and tested to function within controlled environmental conditions. Do not use products under conditions that deviate from methods or applications specified in this datasheet. Failure to employ the products in the proper applications can lead to deterioration, destruction or failure of the products. We shall not be responsible for any bodily injury, fires or accident, property damage or any consequential damages resulting from misuse or misapplication of the products.
8. **Quality Warranty**
 - 8-1. **Quality Warranty Period**

In the case of a product purchased through an authorized distributor or directly from us, the warranty period for this product shall be one (1) year after delivery to your company. For defective products that occurred during this period, we will take the quality warranty measures described in section 8-2. However, if there is an agreement on the warranty period in the basic transaction agreement, quality assurance agreement, delivery specifications, etc., it shall be followed.
 - 8-2. **Quality Warranty Remedies**

When it has been proved defective due to manufacturing factors as a result of defect analysis by us, we will either deliver a substitute for the defective product or refund the purchase price of the defective product.

Note that such delivery or refund is sole and exclusive remedies to your company for the defective product.
 - 8-3. **Remedies after Quality Warranty Period**

With respect to any defect of this product found after the quality warranty period, the defect will be analyzed by us. On the basis of the defect analysis results, the scope and amounts of damage shall be determined by mutual agreement of both parties. Then we will deal with upper limit in Section 8-2. This provision is not intended to limit any legal rights of your company.
9. Anti-radiation design is not implemented in the products described in this document.
10. The X-ray exposure can influence functions and characteristics of the products. Confirm the product functions and characteristics in the evaluation stage.
11. WLCSP products should be used in light shielded environments. The light exposure can influence functions and characteristics of the products under operation or storage.
12. Warning for handling Gallium and Arsenic (GaAs) products (Applying to GaAs MMIC, Photo Reflector). These products use Gallium (Ga) and Arsenic (As) which are specified as poisonous chemicals by law. For the prevention of a hazard, do not burn, destroy, or process chemically to make them as gas or power. When the product is disposed of, please follow the related regulation and do not mix this with general industrial waste or household waste.
13. Please contact our sales representatives should you have any questions or comments concerning the products or the technical information.



Nisshinbo Micro Devices Inc.

Official website

<https://www.nisshinbo-microdevices.co.jp/en/>

Purchase information

<https://www.nisshinbo-microdevices.co.jp/en/buy/>