

TECHNICAL SPECIFICATION

Lithium-ion Capacitor

Model: SLCL1016

Established date: 2019. 1. 26

	Position	Signature	Date
Draft	Technical engineer		
Checked	Technical manager		
Approved	General Manager		

WUHAN FANSO TECHNOLOGY CO.,LTD

Address:Rd.5, Sitai Industrial Park, Yongfeng Avenue, Hanyang District, Wuhan City, China

Postal Code: 434000 Tel: 027-84453199

Revision record

Version	Reviser	Date	Ver No.	Revise page
0	Hui Yang	2019.1.26	A/0	All

1. Scope

The document applies to SLCL1016 supplied by WUHAN FANSO TECHNOLOGY CO.,LTD. Specify quality, test method, performance, quality assurance and matters need attention etc..

2. Capacitors type

Lithium-ion Capacitor

3. General characteristics

No.	Items	Criteria	Remark
01	Rated Voltage	3.8 V	
02	Min. Operating Voltage	2.5 V	
03	Rated Capacitance	30F (or 15mAh)	onstant current I charge to rated voltage 3.8V and then discharge to 2.2V
04	Capacitance Tolerance	± 20%	
05	Surge Voltage	4.2 V	

06	ESR _{AC}	250 m Ω	Test with 1KHz
07	ESR _{DC}	550 m Ω	
08	Rated Charge/discharge Current	0.15A	
09	Max. Charge/discharge Current(≤3sec)	1A	
10	Self-discharge current	≤1 μ A	3 months
11	Leakage Current	≤3 μ A	96h
12	Operating Temperature Range	-40~+70℃/85℃(3.5V)	
13	Storage temperature Range	-25~+85℃	
14	Cycle Life	≥500,000 cycles	
15	Weight	2.5±0.5 g	

4. Environmental performance

No.	Items	Specification/Condition
01	Temperature Characteristics	ΔC/C ≤10%, ESR _{AC} ≤ specified ESR _{AC} at +70℃ ΔC/C ≤50%, ESR _{AC} ≤ 10 times of specified ESR _{AC} at -15℃
02	High temperature loaded	ΔC/C ≤30%, ESR _{AC} ≤ 2 times of specified ESR _{AC} at +70℃ / 1000hrs/Rated voltage
03	High temperature storage	ΔC/C ≤30%, ESR _{AC} ≤ 2 times of specified ESR _{AC} at +85℃ / 1000hrs +85℃,
04	Humidity Resistance	+40℃, 90--95%RH, 240h, ΔC/C ≤30%, ESR _{AC} ≤ 2 times of specified ESR _{AC}

5. Appearance and structure

5.1 Appearance

No scratch, swelling, deformation, corrosion, electrolyte leakage and other defects.

5.2 Structure

SLCL1016 is "spiral design" structure .

6. Safety and environmental performance

6.1 Environmental test

6.1.1 Temperature cycling test

Capacitors are placed in a test chamber and subjected to the following cycles:

a= temperature raise to $70\pm 3^{\circ}\text{C}$ within 30mins, and maintaining for 4h.

b= temperature release to $20\pm 3^{\circ}\text{C}$ within 30mins, and maintaining for 2h.

c= temperature release to $-40\pm 3^{\circ}\text{C}$ within 30mins, and maintaining for 4h.

d= temperature raise to $20\pm 3^{\circ}\text{C}$

e= Repeating the sequence for a further 9cycles.

f= after 10 times cycles, Capacitors be static placed for 7 days.

Pass criteria: the samples shall not explode or catch fire. In addition, the samples shall no leakage.

6.1.2 Low pressure (Altitude Simulation) test

Sample Capacitors are to be stored for 6h at an absolute pressure of 11.6KPa(1.68psi) and a temperature of $20\pm 3^{\circ}\text{C}$ ($68\pm 5^{\circ}\text{F}$)

Pass criteria: The Capacitors shall be no explosion or catch fire as a result of the altitude simulation test. In addition the samples shall be no vent or leakage.

6.1.3 Free fall test

Each cell should be dropped from 1.9m height onto cement ground (total 10 times).

Pass criteria: The Capacitor samples shall be no explosion or catch fire. In addition, the samples shall no vent or leakage.

6.1.4 Vibration test

Capacitor vibration frequency is to be varied at the rate of 1 hertz per minute between 10 and 55 hertz, and return in not less than 90 or more than 100 minutes. The Capacitors is to be tested in three mutually perpendicular directions

Pass criteria: The Capacitor samples shall be no explosion or catch fire. In addition, the samples shall no vent or leakage.

6.2 Safety test

6.2.1 Heating test

Capacitors is heated in a gravity convection or circulating air oven. The temperature of the oven is to be raised at a rate of $5\pm 3^{\circ}\text{C}$ per minute to a temperature of $130\pm 2^{\circ}\text{C}$ and remain for 10 minutes at that temperature before the test is discontinued.

Pass criteria: The Capacitor samples shall be no explosion or catch fire.

6.2.2 Impact test

A test sample cell was placed on a flat surface. A 5/8 in. (15.8 mm) diameter steel bar was placed across the center of the sample. The length of the bar should be at least as long as the width of the sample. A 20 pound (9.1 kg) weight was dropped from a height of 24 ± 1 in. (610 ± 25 mm) on to the sample.

Pass criteria: The samples shall not explode or catch fire.

6.2.3 Crush test

A cell was crushed between two flat hard surfaces (i.e. steel). The crushing was continued until a force of

3000 pounds (13kN±0.78kN) was applied by hydraulic piston with a diameter of 32mm. press continue until pressure reach up to 17.2Mpa. Once the maximum pressure was obtained, it was released.

Pass: The Capacitors samples shall be no explosion or catch fire.

6.2.4 External Short-circuit test

Connect the Capacitors positive and negative terminal with Cu wire(internal resistance < 0.1 ohm), Capacitors was discharged until a fire or explosion was obtained, or until it had reached a completely discharged and the cell case temperature had returned to ambient temperature.

Pass criteria: The Capacitor samples shall be no explosion or catch fire.

6.2.5 Force recharging

A completely discharged cell is to be force-discharged by connecting it in series with fully charged cells of the same kind. The number of fully charged cells to be connected in series with the discharged cell is to equal the maximum number less one of the cells to be covered for series use, the circuit load resistance less than 0.1Ω. The sample is to discharge until a fire or explosion is obtained, or until it has reached a completely discharge state of less than 0.2V and Capacitor case temperature has returned to $\pm 10^{\circ}\text{C}$ (+18°F) of ambient temperature.

Pass criteria: The samples shall be no explosion or catch fire.

7. Outgoing inspection

FANSO will execute 100% inspection Capacitors open circuit voltage of the Capacitors (OCV) and the load voltage, Also FANSO will sampling tests the Capacitors capacity, visual appearance and size. FANSO recommended sampling according to GB2828 5-3 standard, Actually sampling plan, inspection items, criteria and other matters have been negotiated by the supply and demand parties.

7. Storage

Capacitors should be stored in a cool, clean, dry environment, the recommended temperature is $\leq +30^{\circ}\text{C}$, relative humidity $\leq 60\%$, should avoid contact with corrosive materials, away from fire and heat.

9.1 Precautions and Handling Guidelines

For safety application, please contact FANSO directly for any technical specifications, handling precautions and guidelines critical to application.

4.1 Precautions

1) Prohibition of disassembly

The disassembly may generate internal short circuit in the capacitor, which may cause gas, leakage, explosion or other problems.

2) Prohibition of dumping capacitors into fire

These may cause explosion of the capacitors, which is very dangerous and forbidden.

3) Prohibition of capacitors immersion into water or seawater

The capacitors shall never be immersed into water, seawater or other similar liquid, and keep the capacitors in a cool dry environment during no using.

4) Prohibition of using damaged capacitors

The capacitors may be damaged during shocking of shipment. If any abnormal features of the capacitors are found such as damages in the package, electrolyte leakage, drumming gas or others, prohibition of using the capacitors.

The capacitors with an electrolyte smell or leakage should be placed away from fire to avoid fire or explosion.

5) Prohibition of short-circuit or using for outside the working voltage

which may cause to gas, leakage, explosion or other problems.

6) Prohibition of reversing the positive(+) and negative(-) terminals.

Which may cause to gas, leakage, explosion or other problems

4.2 Handling Guidelines

- 1) It's not suitable for such conditions: AC circuit and wave filtering.

Working voltage should not exceed to the Max. working voltage of capacitors when using.

- 2) Please check the polarity before using. If working under reverse polarity, capacitors will not only shorten shelf life, even cause to swell, electrolyte leakage.
- 3) Environment: Working temperature has an influence on shelf life of capacitors, which can't exceed to the high temperature of capacitors.
- 4) IR drop: We should consider the voltage drop and heat with the IR drop , when using the capacitors with a big power charge/discharge. The IR drop usually be specified in the datasheet.
- 5) Capacitors in series connection: When capacitors in series connection for higher voltage, it should be assured that working voltage of any singer capacitor must not exceed to the limit of the max. and min. working voltage.

Soldering: Please use manual soldering for breadboard. Don't use reflow soldering or wave-soldering of infrared heating and air heating. Heat shock will decrease electric performance of capacitors, even cause to swell, leakage or crack. Soldering temperature should not exceed 260℃ and soldering time not exceed 5s.

3. Statement

Prior to use of the product, it must be operated in strict accordance with this product specification. Misuse may cause safety problems and can cause bodily injury or property damage. For any accident does not operate according to the product specification, Wuhan Fanso Technology Co., LTD does not undertake any responsibility.

10.Product image and dimension drawing

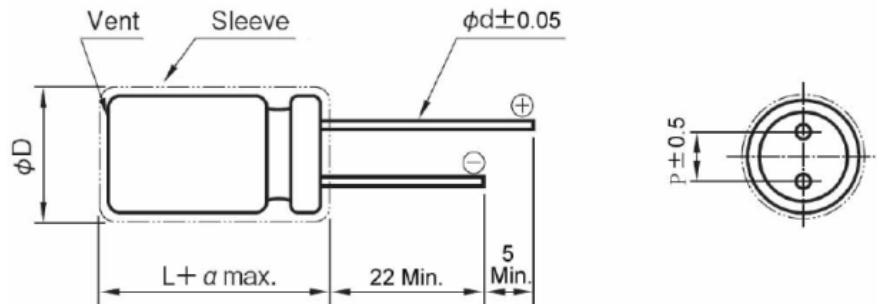

Model	Items	Criteria	Items	Criteria
SLCL1016	D	10.0 ± 0.5	L	16.0 ± 2.0
	p	5.0 ± 0.5	d	0.6 ± 0.5